



CX86e

COLOUR TAG PRINTER

User's Manual

©2021, DTM Print GmbH. All rights reserved

For the most recent version of this manual please visit dtm-print.eu/manuals

Version 02 - CX86e-190808BETA



Technical DTM Print Support

Contact the DTM Print support team during the official business hours using the online live chat on our website dtm-print.eu.

Alternatively, fill in the support form at support.dtm-print.eu or send us an e-mail at any time to support@dtm-print.eu.

This service is free for all our customers.

Please be aware that you have to be registered with your product first, to get free support. Register your device here: register.dtm-print.eu



Table of Contents



1. Read This First	8
Safety Precautions	8
General Precautions	8
Other Cautions.....	10
Regarding the Printing of Paper Currency and Securities, etc.....	10
Regarding the Prevention of Electromagnetic Interference	10
Regarding the Regulation of Harmonic Waves	10
Caution When Taking This Product Outside of Japan	10
Trademarks.....	10
Screens.....	11
Marks	11
Symbols	11
Illustrations.....	11
Licenses	12
2. Unpacking	14
How to Unpack the Machine	14
Checking the Accessories	14
Installing Consumables	15
3. Using the Machine	19
Installation.....	19
Installation Environment.....	19
Installation Space.....	20
Names of Components	21
Front View	21
Rear View.....	22
Side of the Machine.....	22
Inside of the Machine	23
Installing Options	23
Installing the Wireless LAN Module.....	24
Installing the Presenter Unit.....	27
Turning On or Off the Machine.....	31
Turning On the Machine.....	31
Turning Off the Machine	32
Connecting a LAN Cable	33
Connecting via Wireless LAN	34
Preparing to Connect via Wireless LAN.....	34
Connecting via an Access Point (Infrastructure).....	34
Directly Connecting to the Machine (AP Mode).....	36
Using Both a Wired LAN and Wireless LAN Connection	36
Connecting a USB Cable.....	37
Installing the Printer Driver to a Computer	38
4. Using the Operation Panel.....	39
Name and Function.....	39
Description of the Display	40
When Printing Can Be Performed	40
When an Error Has Occurred in the Machine.....	40
When the Machine Is in the Menu Mode	40



Entering and Viewing the Menu.....	41
Entering Characters	43
Printing a Demonstration Page	44
Adjusting the Volume.....	44
Setting the Volume.....	44
Setting the Volume for the Printing Complete Buzzer	45
Checking Information About the Machine.....	46
Printing and Checking a Report.....	46
Checking the Operation Panel	46
Setting the Power Save Mode Transition Time.....	47
Setting the Sleep Mode Transition Time.....	47
Precautions for the Power Save Function	47
Setting the Auto Power Off Time	48
Enabling Auto Power Off.....	48
Setting the Time Until Auto Power Off.....	48
Initializing the Flash Memory	49
Initializing the Network Settings.....	50
Initializing the Settings of the Machine.....	51
Changing the Administrator Password.....	51
Correcting the Color Density	52
Adjusting the Color Balance (Density)	52
Correcting Color Shift.....	52
Adjusting the Paper Sensors (Sensor Calibration)	53
Menu List	54
DEMO PAGE.....	54
CONFIGURATION	55
PRINT INFO	57
MENUS	57
ADMIN SETUP	62
PRINT STATISTICS.....	68
CALIBRATION	68
WIRELESS SETTING	69
WIRELESS (AP MODE) SETTING	70
BOOT MENU	70
5. Loading Paper	72
Available Paper Sizes	72
Paper Specifications.....	72
Paper Storage.....	76
Flow of Loading Paper	77
Setting Paper Information on the Operation Panel	78
Setting the Paper Sensors.....	80
Checking the Paper Sensor Position	80
Adjusting the Paper Sensor Position.....	82
Attaching the Guide Ribs	84
Loading Paper	86
Feeding the Paper.....	89
6. Printing.....	91
Registering Paper Information to the Printer Driver	91
Adjusting the Paper Sensors (Sensor Calibration).....	92



Printing from a Computer.....	93
Printer Driver Screens and Functions	93
[Setup] Tab.....	93
[Color] Tab.....	94
[Overlays] Tab	95
[Extend] Tab.....	96
Registering Frequently Used Settings (Favorites)	96
Specifying the Print Orientation.....	97
Rotating the Print Result 180 Degrees	97
Specifying the Number of Prints	97
Printing from the Last Page.....	98
Cutting Every Specified Number of Pages.....	98
Changing the Print Quality.....	98
Printing with the Photo Mode	99
Correcting Barcodes for Printing.....	99
Changing the Color Settings	100
Reducing Toner Consumption When Printing.....	100
Overlaying Text or Logos When Printing.....	100
Registering Print Documents as New Forms	101
Saving the Documents to Print as Files in the Form Format	101
Printing Hidden Text (Watermarks)	102
Printing with a Specified Font.....	102
Adjusting the Rendering Position.....	103
Reducing the Size of Spool Files (Disabling EMF)	103
Keeping the Page Layout when Resizing a Document	103
Correcting Faintness in Thin Lines and Small Text	104
Executing Drum Cleaning Before Printing.....	104
Skipping Blank Pages	105
Printing Using the Presenter Unit	105
Removing the Windows Printer Driver.....	107
7. Replacing Consumables.....	108
Cautions for Replacing Consumables.....	108
Replacing the Toner Cartridge	109
Replacing the Image Drum Unit.....	112
When the Lightproof Film Is Dirty.....	117
Replacing the Fuser Unit	118
Replacing the Transfer Belt Unit	121
Replacing the Feed Roller	124
Replacing the Paper Feed Roller	127
8. Cleaning the Machine.....	132
Cleaning the Surface of the Machine	132
Cleaning the LED Head	132
Cleaning the Feed Rollers	134
Cleaning the Paper Feed Rollers.....	136
9. Troubleshooting	137
When the LED Lights Up	137

When the Paper Is Jammed.....	137
Error 381/730-06 (Paper on the Transfer Belt Unit)	137
Error 382 (Paper Jammed in the Fuser Unit).....	139
Error 380/390 (Paper Jammed Near the Cutter).....	142
Canceling Printing	144
Pressing «CANCEL» Button	144
Canceling from a Computer	144
Cannot Print.....	144
List of Messages.....	145
Connection Problems.....	150
Network Connection Problems.....	150
Wireless LAN Connection Problems.....	150
USB Connection Problems	151
Print Result Problems	152
List of Print Result Problems.....	153
White Streaks Appear in the Vertical Direction	153
Horizontal White Streaks Periodically Appear in the Paper Feed Direction	154
The Printing Is Faint in the Vertical Direction	155
Printing Is Light.....	155
White Dots and Lines Appear	156
Condensation Occurs in the Printed Paper.....	156
Streaks Appear in the Vertical Direction	156
Dots and Horizontal Streaks Periodically Appear in the Paper Feed Direction	157
White Background Areas Are Faintly Dirty.....	157
Bleeding Occurs Around Text	157
Toner Comes off When Rubbed.....	158
Gloss Is Uneven.....	158
Black Dots or White Dots Appear	158
Dirt Is Printed.....	159
The Entire Page Is Printed in Black	159
Nothing Is Printed	159
Parts of the Image Are Missing.....	159
The Area Around the Image Is Dirty	160
The Colors of the Image Are Unexpected	160
The Black of CMY 100% Is Light	160
The Precision of the Barcode Reading Is Low	161
Software Problems	161
Web Browser Problems	161
Windows Problems.....	161
Machine Problems.....	162
The Machine Does Not Operate	162
Nothing Is Displayed on the Screen when the Power Is Turned On	162
Printing Does Not Start	162
Print Data Is Not Sent.....	164
An Abnormal Smell Is Emitted	165
A Resonant Sound Is Emitted	165
Printing Stops Before It Is Complete	165
Memory Runs Out.....	165
Printing Is Slow.....	165
The Power Turns Off Automatically.....	166
Paper Problems.....	166
Paper Jams Frequently Occur/The Paper Is Pulled in at an Angle.....	166
The Machine Does Not Recover When the Paper Jam Is Removed	166











The Paper Curls/The Paper Wrinkles	167
The Paper Gets Stuck in the Roller of the Fuser Unit.....	167
Paper Sticks to the Transfer Belt Unit	167
Paper Corners Are Folded	167
The "308:PAPER JAM" error occurs when paper is not loaded	168
When a Power Failure Occurs	168
Moving the Machine.....	168
Transporting the Machine	169
Before Leaving the Machine	169
10. Management Software	170
Type of Software	170
Installing Software.....	170
Web Page	170
Web Page Settings.....	170
Starting the Web Page.....	171
Logging In as the Administrator	172
Checking or Changing the Status of the Machine	175
Encrypting Communication (SSL/TLS)	177
Using IPP.....	180
Encrypting Communication (IPSec)	180
Using the IP Address Access Control Function (IP Filter)	185
Using the MAC Address Access Control Function	186
E-Mail Alert	186
Using SNMPv	186
Using IEEE802.1X (Wired LAN).....	186
Configuring IEEE802.1X (Wireless LAN)	191
Configuration Tool.....	193
Registering the Machine	193
Starting the Configuration Tool	193
Checking the Status of the Machine	193
Changing the Menu Settings.....	194
Copying Settings (Cloning)	199
Configuring the Network	200
Registering Forms (Form Overlay)	201
Checking the Free Memory/Storage Space.....	204
Removing the Machine.....	204
Names and Functions of Each Screen.....	204
Status Monitor	207
System Requirements.....	207
Starting the Status Monitor.....	207
Displaying the Printer Status	208
Switching the Printer Settings.....	208
Switching the Status Monitor Settings.....	208
11. Specifications.....	211
General Specifications.....	211
Printing Specifications	211
Network Related.....	212
List of Included Fonts	213
Consumables/Maintenance Parts/Options	213







Read This First





Safety Precautions

 WARNING	Ignoring these instructions and improperly handling the machine may lead to death or serious injury.
 CAUTION	Ignoring these instructions and improperly handling the machine may lead to injury.

General Precautions

 WARNING	
	Do not touch the safety switch inside the machine. High voltage that can cause electric shock may result. Injury may also result from the turning of gears.
	Do not use flammable sprays near the machine. Fire may result due to the high temperature parts inside the machine.
	If the cover becomes abnormally hot, smoke is emitted, or a strange smell or noise is emitted, remove the power plug from the outlet and contact your dealer. Fire may result.
	If liquid such as water enters the inside of the machine, remove the power plug from the outlet and contact your dealer. Fire may result.
	If a foreign object such as a paper clip is dropped inside the machine, remove the power plug from the outlet and contact your dealer. Electrocutation, fire, or injury may result.
	Do not operate or assemble the machine except as indicated in the user's manual. Electrocutation, fire, or injury may result.
	If the machine is dropped or the cover is damaged, remove the power plug from the outlet and contact your dealer. Electrocutation, fire, or injury may result.
	Remove the power plug from the outlet periodically and clean the base of the prongs and between the prongs. A fire caused by a short circuit may result due to dust accumulating at the base of the power plug prongs if the power plug is left in the outlet for an extended period of time.
	Do not vacuum spilled toner with an electric vacuum cleaner. Vacuuming spilled toner with an electric vacuum cleaner may result in ignition due to sparks from electric contacts or other reasons. If toner is spilled on the floor, etc., gently wipe it away with a wet rag, etc. to ensure that the toner does not scatter.
	Do not insert objects into the air vents. Electrocutation, fire, or injury may result.

 WARNING	
	Do not place objects such as cups of water on the machine. Electrocutation or fire may result.
	Ensure that pet urine does not enter or wet the machine. Electrocutation or fire may result.
	If you open the cover of the machine, do not touch the fuser unit. Burns may result.
	Do not throw a used image drum or toner cartridge into a fire. A dust explosion or burns may result.
	Do not connect a power cord, cable, or ground wire other than those indicated in the user's manual. Fire may result.
	Operation is not guaranteed if a UPS (uninterruptible power supply) or inverter is used. Do not use an uninterruptible power supply or inverter. Fire may result.

 CAUTION	
	Keep away from the paper outlet when turning the power on and while printing. Injury may result.
	Do not touch a broken LCD display. Injury may result. If liquid (liquid crystal) that leaks from the LCD display gets into your eyes or mouth, immediately rinse them with a large amount of water. Also seek medical advice, as required.
	Do not disassemble or forcibly open the image drum or toner cartridges. The toner may be scattered, causing you to inhale the toner or get your hands or clothes stained with the toner.

Other Cautions

Regarding the Printing of Paper Currency and Securities, etc.

- The duplication and printing of items such as paper currency (including foreign paper currency), national bonds, municipal bonds, postage stamps, and revenue stamps or the creation of similar misleading objects is a crime and punishable by the law, regardless of the intended use.
- The duplication and printing of the following items for the purpose of use as the real thing is punishable as a crime.
- Securities such as stock, bills, and checks
- Documents such as certificates created by a public official or government office
- Documents regarding rights and obligations or proof of facts, such as contracts
- Seals, signatures, or symbols of government offices or public officials
- Seals or signatures of individuals
- The unauthorized duplication of materials protected by copyright law (such as books, magazines, paintings, maps, and photos) is illegal, except for personal or home use, or other corresponding use within a limited scope.
- Related Laws
Criminal Law, Law Concerning the Regulation of Securities Resembling Paper Currency, Act on Control of Imitation, etc. of Revenue Stamps, etc., Act on Control of Imitation, etc. of Postal Stamps, etc., Act on Counterfeit, Alteration and Imitation of Coins, Money Bills, Banknotes and Securities Circulating in Foreign States, Copyright Law

Regarding the Prevention of Electromagnetic Interference

This machine is a class A device. Using this machine in a residential environment may cause electromagnetic interference. In this case, the user may be requested to implement appropriate countermeasures.

Regarding the Regulation of Harmonic Waves

This machine conforms to the JIS C 61000-3-2 standard on harmonic wave currents.

Trademarks

Microsoft, Windows, and Windows Server are trademarks or registered trademarks of Microsoft Corporation in the United States and other countries. Other product names and brand names are trademarks or registered trademarks of their respective owners.

Screens



Unless otherwise specified, this manual uses screens from the following operating system in examples.

- Windows 10

Screens may differ from those in this manual, depending on the operating system, model, and version you are using.

Marks

This manual uses the following marks.

Mark	Meaning
	Indicates cautions for operating the machine correctly. Make sure to read these cautions to ensure that you operate the machine correctly.
	Indicates information that is convenient or useful for using the machine. It is recommended that you read this information.
	Indicates a reference topic. Read when you need more information.

Symbols

This section describes the symbols used in this manual and their meaning.

Symbol	Meaning
« »	Indicates buttons/keys on the operation panel of the machine.
[]	Indicates menu names, item names, and selections displayed on the operation panel. Indicates the menus, windows, and dialog names displayed on the computer screens.
“ ”	Indicates message and entered text displayed on the operation panel. Indicates file names on a computer. Indicates the titles of links.
< >	Indicates keys on the keyboard of the computer.
>	Indicates the menu transition of the machine and the computer.

Illustrations

The operation panel screens used in this manual use the default settings.

Licenses

The software license agreement that customers agree to before using the products included in the package of the machine is indicated below.

- Request for Agreement
- Please make sure to read this agreement before using the products included in the package of the machine.
- When a customer uses the products included in this package, the customer is deemed to have agreed to the terms of this agreement.
- If you do not agree to the terms of this agreement, please return the product to the dealer where it was purchased.

DTM Print GmbH grants the customer non-exclusive rights to use the software included in this package (hereinafter "the software"), based on the following terms. DTM Print GmbH reserves the right to license the use of the software to customers.

Scope of Use

The customer may use the software by installing its programs to multiple computers directly or via a network, only while the customer owns an DTM Print GmbH printer that supports the software. The customer may also make one copy of the software for backup purposes.

Property Rights and Responsibilities

- DTM Print GmbH and its licensors reserve the right to copy, publish, and own the software and its copies. The configuration, structure, and code of the software are important confidential information for the business of DTM Print GmbH and its licensors. The software is protected by copyright law in the United States and Japan and international treaties, and must be handled in the same manner as books and other works.
- Except for the copy indicated in Clause 1, the software may not be duplicated, loaned, rented, leased, transferred, or licensed, in full or in part.
- The customer agrees to not revise, modify, translate, reverse engineer, decompile, or disassemble the software.
- The customer agrees to not rename the software.
- The customer holds no rights regarding the software, except those recognized in this agreement.

Period

- The license granted to the customer for the software is valid until this agreement is terminated.
- The customer can terminate this agreement by discarding and erasing the software and all of its copies.
- DTM Print GmbH reserves the right to terminate the license agreement granted to the customer if the customer violates the terms of this agreement. When this agreement is terminated in such a manner, the customer must discard and erase the software and all of its copies and stop using the software.

Guarantee

- DTM Print GmbH and its licensors do not guarantee anything regarding the software, including the following. That using the software will enable the customer to obtain the desired performance or results. That the software is free from defects. That the software does not violate the rights of third parties. That the software is fit for a specific purpose.
- The software may be modified or changed without notice.

Limited Liability

- DTM Print GmbH and its licensors will not be held responsible for any direct, indirect, or derivative damages or losses caused by the software, even if DTM Print GmbH was aware of the possible of such damages occurring, even if the claim for those damages is based on an illegal act (including, but not limited to negligence), or based on any other legal grounds. Furthermore, DTM Print GmbH and its licensors will also not be held responsible for any claims made by third parties caused by the software or related to the software.

Applicable Law

The license agreement for the software is based on Japanese law, including the formation of this agreement.

Validity of This Agreement

If part of this agreement is deemed invalid and not legally binding, this will not affect the other parts of this agreement, and those other parts will remain valid and legally binding.

Export Control

The software may not be exported to countries prohibited by the export control laws of Japan and the United States or other related laws and regulations, and may also not be used in a way that is prohibited by any law or regulation. The customer agrees to not export or reexport the software or products created from the software without obtaining permission from the government of the United States and Japan. If the customer violates this clause, this agreement is terminated automatically.

Unpacking

How to Unpack the Machine

 Packaging and cushioning materials are used for transporting the machine. Do not dispose of them, and keep them for future use.

- ▶ Remove the machine from the box, and then remove the cushioning material and plastic bag.
- ▶ Lift the machine, and then place it where it is to be installed.

 For details on the installation location, refer to "Installation".

Checking the Accessories

Check that you have everything shown below.

Be sure to use the consumables supplied with the machine first. If consumables other than the supplied ones are installed first, the life time may not be shown correctly or supplied consumables may become unusable.

Main Body

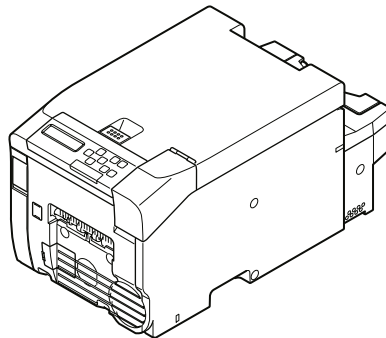

Toner Cartridge

A toner cartridge can print approximately 5,000 pages (reference value based on DTM Print GmbH tests printing simple 1 inch square black mark patterns).

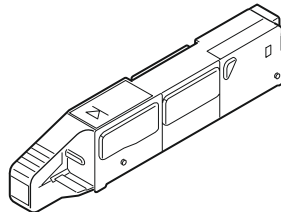

Guide Rib

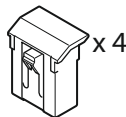

Power Cord

A LAN cable and USB cable are not included. Prepare cables suitable for the connection environment.

Packaging, cushioning materials, and cover toner are used for transporting the machine. Do not dispose of them, and keep them for future use.

Installing Consumables

- ⓘ Do not turn the power of the machine on.
 - ▶ Install the consumables after confirming that the power of the machine is off.
 - ▶ Use extra care when handling the image drum (the glossy cylinder), because it is fragile.
 - ▶ Do not expose the image drum unit to direct sunlight or strong light (approximately 1,500 lux or more). Do not leave the image drum unit exposed for 5 minutes or more, even under room lighting. When the image drum unit will be left alone for 5 minutes or more, cover it with black paper, etc. to prevent it from being exposed to light.

Insert your finger into the recess on the top of the machine and pull up the lever.

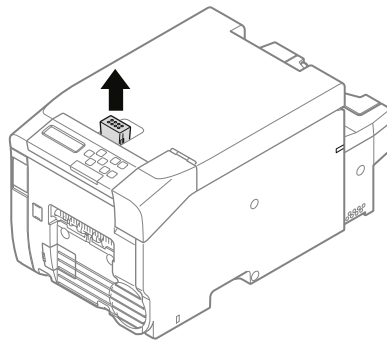

Open the top cover until it stops.

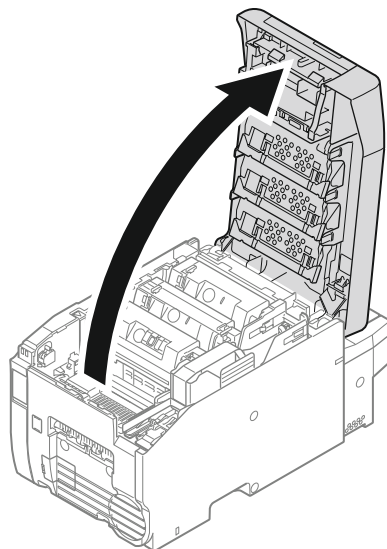

Peel off the protective tape.

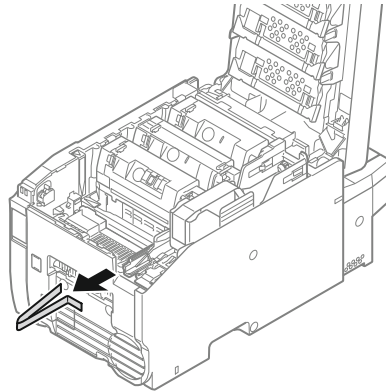

Peel off the protective tape, and remove the desiccant.

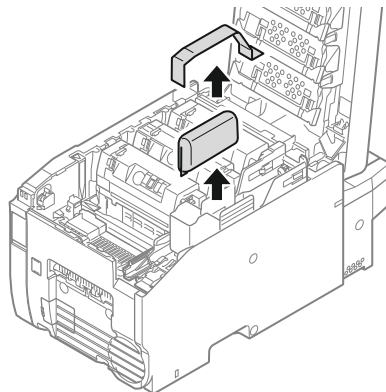

Remove the cover toner.

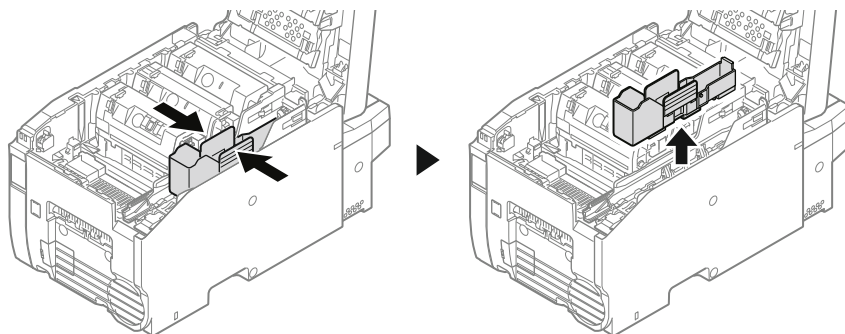

Close the top cover.

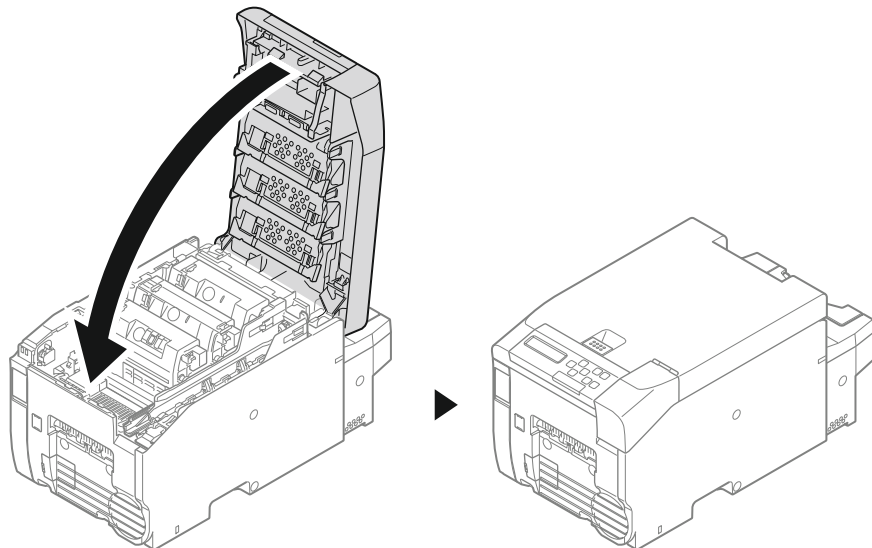

Open the toner cartridge cover.

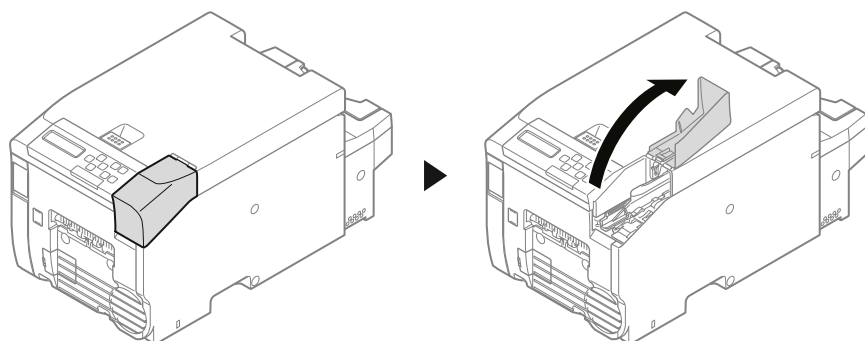

Take out the toner cartridge from the packaging bag, and shake it several times vertically and horizontally.

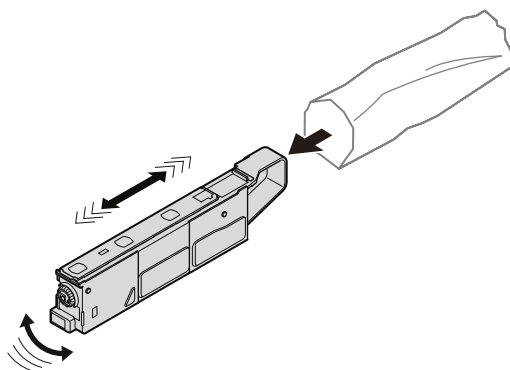

Place the toner cartridge in the direction that it will be attached to the machine.

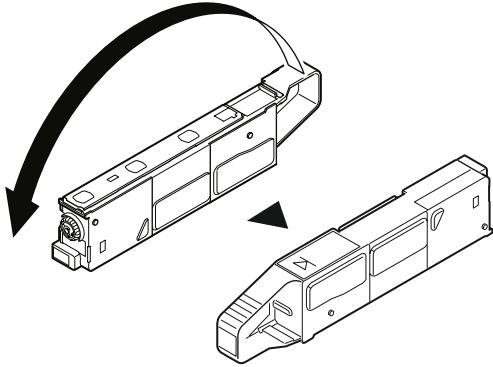

Attach the toner cartridge.

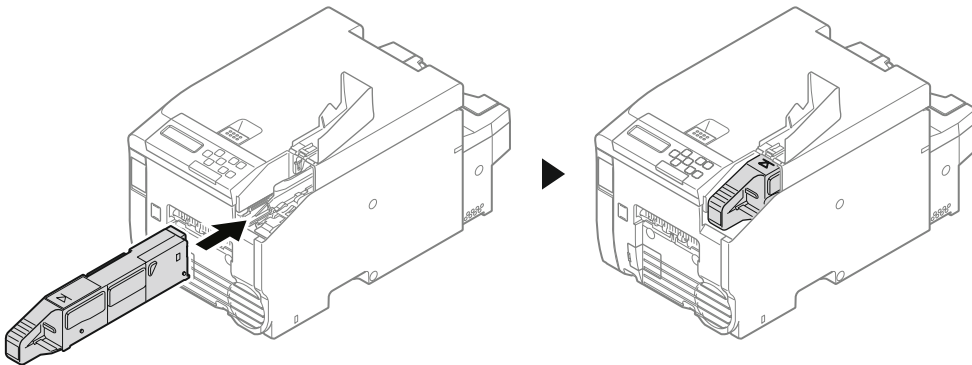

Close the toner cartridge cover.

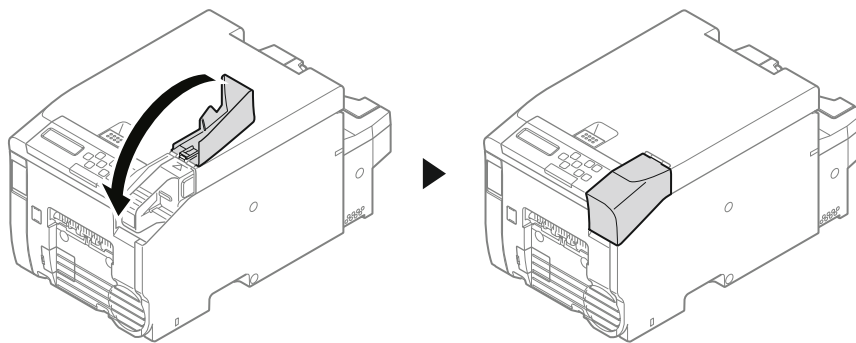

Installation

Installation Environment

Install the machine in the following environment.

- ▶ Ambient temperature: 10°C to 32°C
- ▶ Ambient humidity: 20% to 80% RH (relative humidity)
- ▶ Maximum wet bulb temperature: 25°C



- Use care to prevent condensation. It may cause a malfunction.
- If you install the machine in a location whose ambient humidity is 30% RH or below, use a humidifier or anti-static mat.
- Depending on the installation environment, the machine may emit bothering operation noise. If the noise bothers you, we suggest the machine be installed in a location away from you or in another room.

WARNING

- Do not install the machine in a location subject to high temperatures or in a location near fire.
- Do not install the machine in a location where chemical reactions may occur (such as a laboratory).
- Do not install the machine near alcohol, thinners, or other flammable solvents.
- Do not install the machine in a location within the reach of small children.
- Do not install the machine in an unstable location (such as on an unsteady stand or slanted location).
- Do not install the machine in a location subject to high level of humidity, dust, or direct sunlight.
- Do not install the machine in an environment exposed to salty air or corrosive gas.
- Do not install the machine in a location subject to much vibration.
- Do not install the machine in a location where its vent hole is blocked.

CAUTION

- Do not install the machine directly on a thick rug or carpet.
- Do not install the machine in a location with bad circulation and ventilation such as a closed room.
- Make sure to ventilate the room if you use the machine in a small room continuously for an extended period of time.
- Install this machine away from a source that emits strong magnetic fields or noise.
- Install this machine away from a monitor or television.

Installation Space

Install the machine on a flat surface that is wide enough to accommodate the legs of the machine.
As shown in the following figures, allow enough space around the machine.

Top View

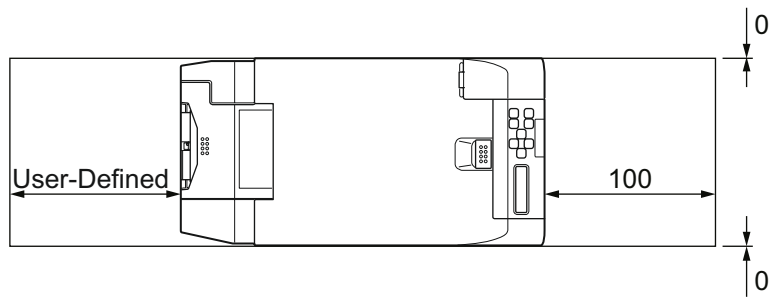

Side View

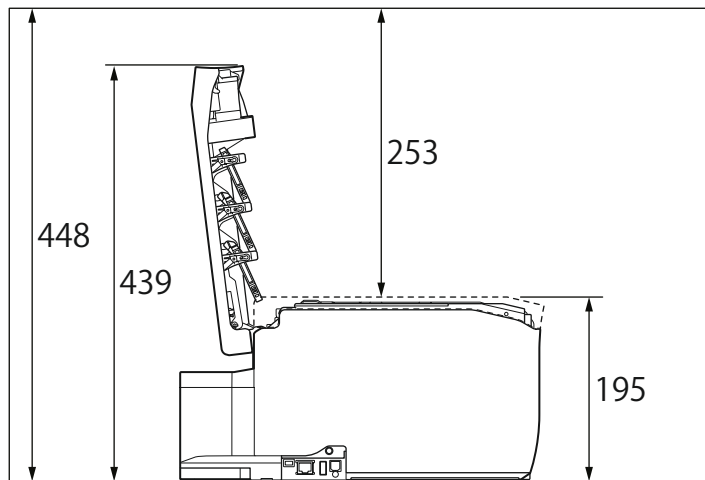

Names of Components

Front View

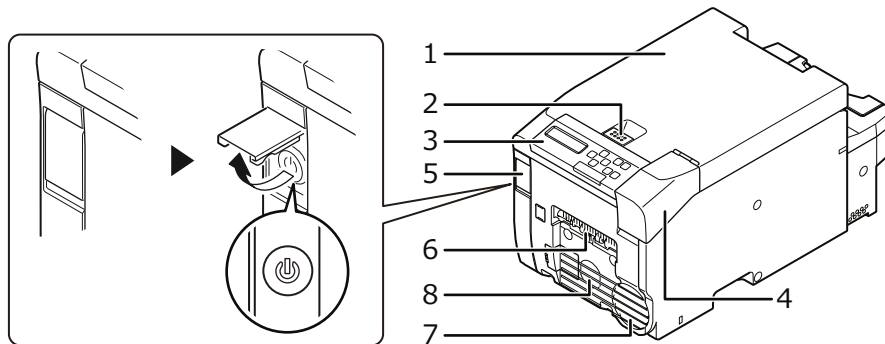

No.	Name	Description
1	Top Cover	The top cover of the machine. Close this when printing.
2	Top Cover Lever	Use this to open the top cover.
3	LCD Panel	Indicates the status of the machine and the settings.
4	Toner Cartridge Cover	Opens and closes when replacing the toner cartridge.
5	Power ON/OFF Switch	The power switch cover. Open the cover to find the power switch.
6	Paper Outlet	Outputs printed paper.
7	Air Outlet	The air vent.
8	Buzzer	The buzzer. Can be set to sound when an error occurs in the machine.

Rear View

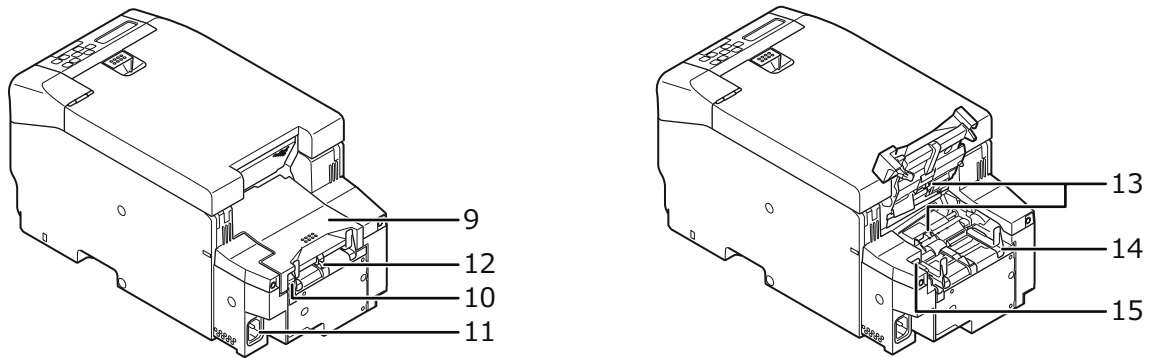

No.	Name	Description
9	Feeder Cover	The cover of the paper feeder.
10	Feeder Cover Lever	Use this to open the feeder cover.
11	AC Inlet	The terminal for the power cable.
12	Paper Inlet	Load paper here.
13	Paper Sensor	The sensor for detecting the paper.
14	Paper Guide	Align this with the paper width.
15	Paper Guide Lever	Fixes the Paper Guide.

Side of the Machine

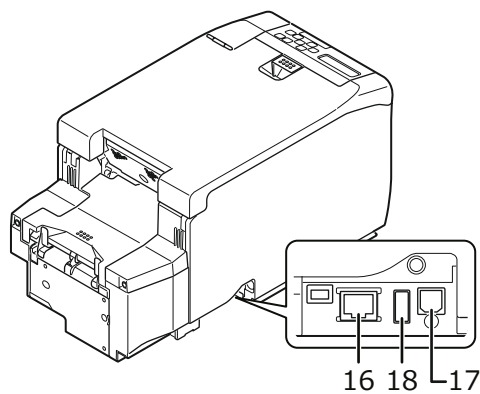

No.	Name	Description
16	LAN	The terminal for the LAN cable.
17	USB	The terminal for the USB cable.
18	W-LAN	The slot for the Wireless LAN Module.

Inside of the Machine

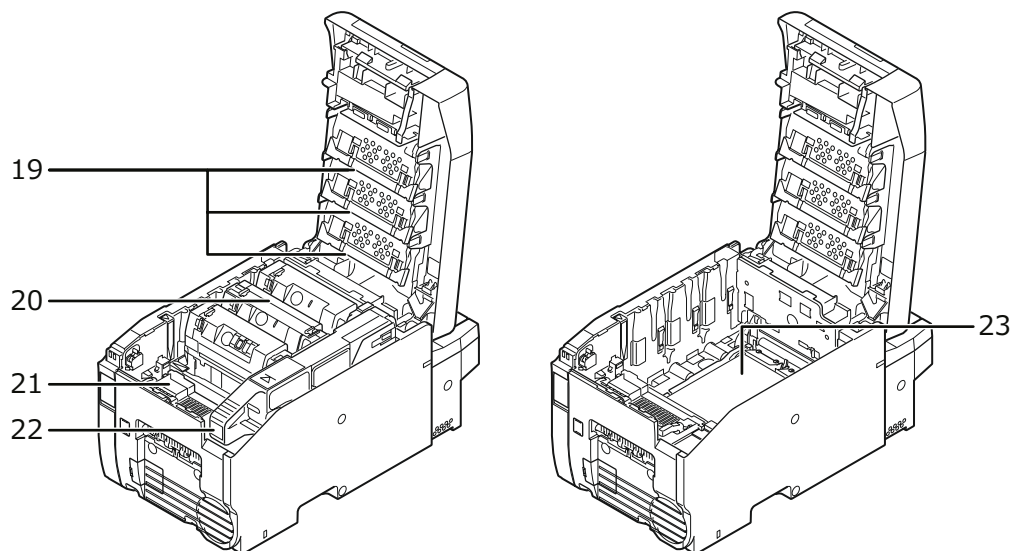

No.	Name	Description
19	LED Heads	The LED heads.
20	Image Drum Unit	The image drum unit.
21	Fuser Unit	The fuser unit. Take care, as this becomes hot while printing.
22	Toner Cartridge	The toner cartridge.
23	Transfer Belt Unit	The transfer belt unit. This is set below the image drum unit.

Installing Options

The machine has the following optional products.

Wireless LAN Module

- ▶ Installed to connect via wireless LAN.

Presenter Unit

- ▶ Installed to stop the printed paper before it is fully ejected.

Installing the Wireless LAN Module

Install the Wireless LAN Module to connect the machine and a computer via wireless LAN.

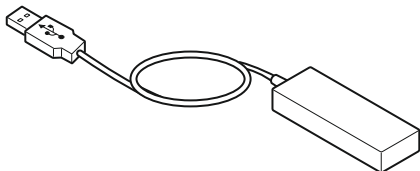

Turn off the machine.

For information on turning off the machine, refer to "Turning Off the Machine".



Insert the Wireless LAN Module into the connector on the side of the machine.

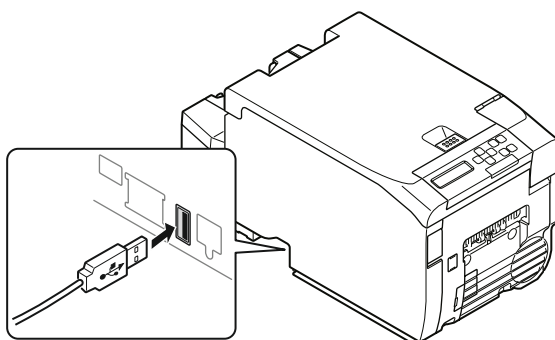

Attach the Wireless LAN Module anywhere on the machine using the supplied hook-and-loop fastener.

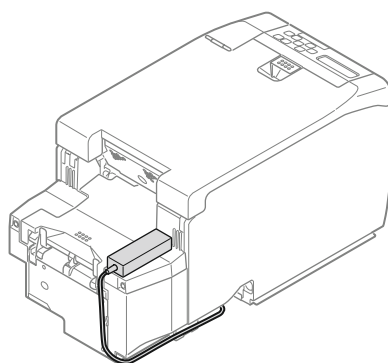

Turn the machine on while holding «OK» button on the operation panel.

- ▶ Hold «OK» button until [BOOT MENU] is displayed on the screen.

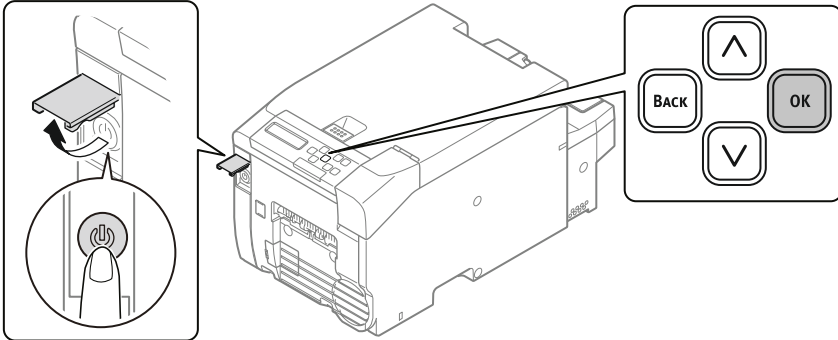

When [BOOT MENU] is displayed, release your finger and press «OK» button again.

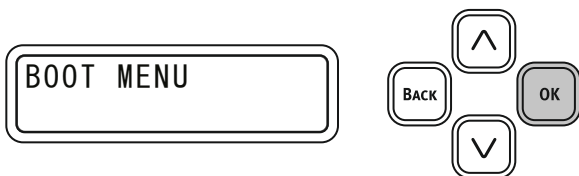

When [ENTER PASSWORD] is displayed, enter the password.

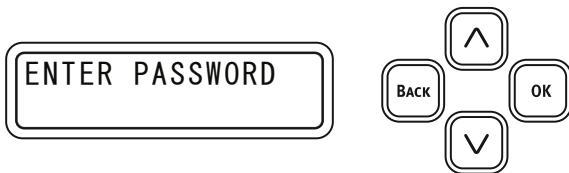

- ▶ The default password is "999999."

When the password has been entered, press OK button.

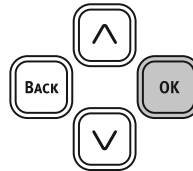

Press ^ button or v button to display [WIRELESS MODULE], and press «OK» button.

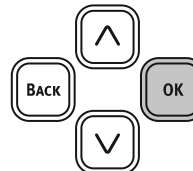

Press ^ button or v button to display [ENABLE], and press OK button.

▶ * is displayed on the right edge of the bottom of the screen.

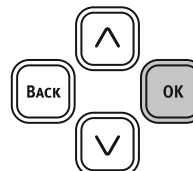

Press «ONLINE» button to return to the [READY TO PRINT] standby status.

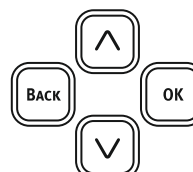
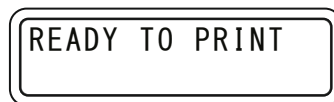

Installing the Presenter Unit

The Presenter Unit is installed to retain the printed paper in the outlet without ejecting it.

When installation of the Presenter Unit is complete, set the Presenter Unit to [ENABLE] on the operation panel.

Turn off the machine.



For information on turning off the machine, refer to "Turning Off the Machine".

Remove Cover-Front-Sub-A.

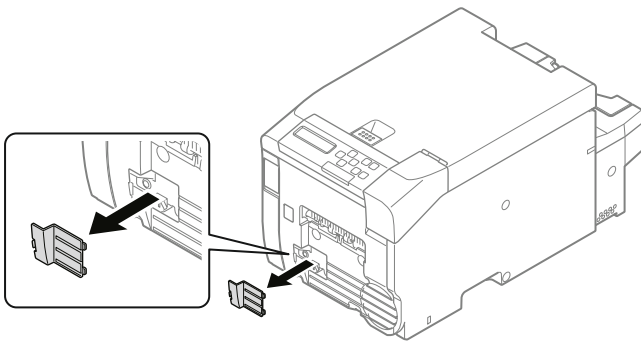

Remove Cover-Front-Sub-B.

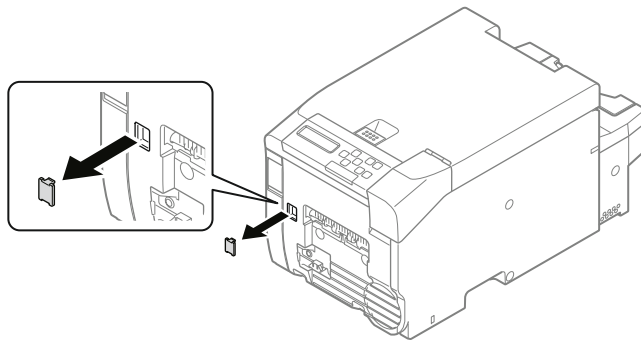

Remove the Label-Cap (x 2).

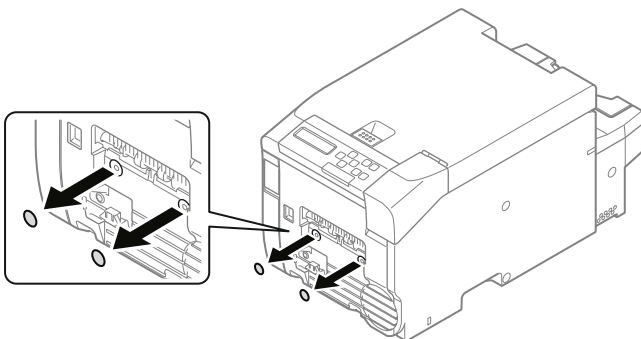

Remove the Cap-Cover-PSNT (x 2) of the Presenter Unit.

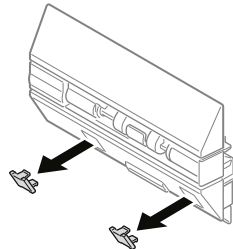

Mount the Presenter Unit to the machine.



Take care, as it will not be completely secure.

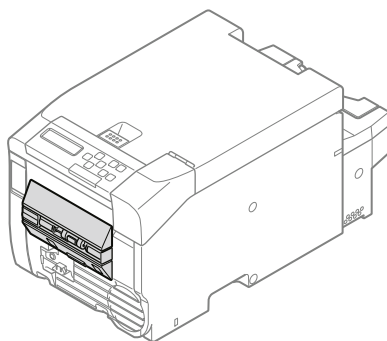

Tighten the screws (x 2).

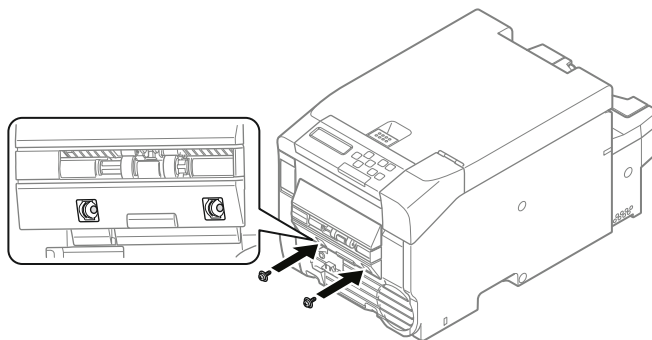

Connect the connector.

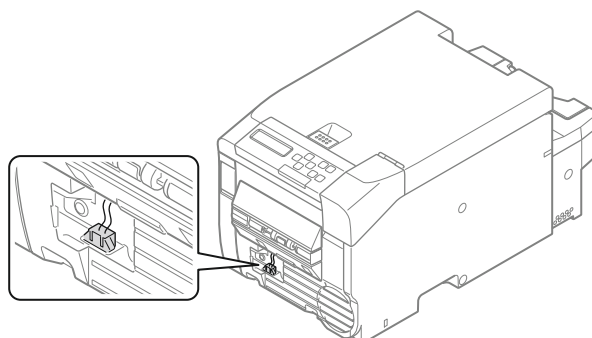

Attach the Cover-Cable-PSNT.

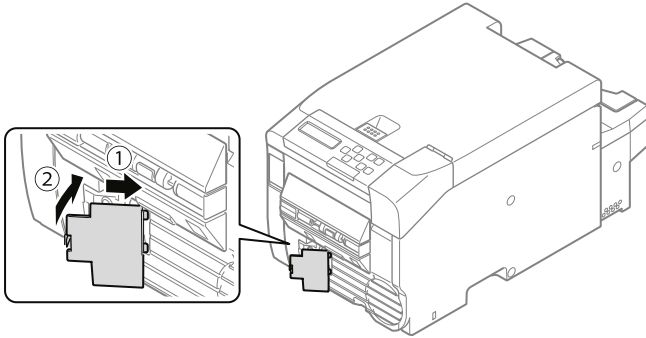

Attach the Cap-Cover-PSNT (x 2).

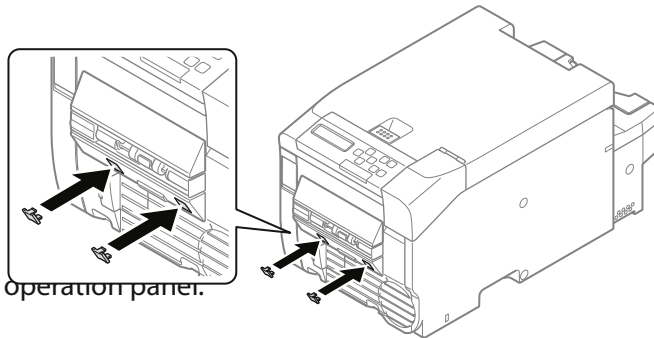

Enable the Presenter Unit on the operation panel.

Turn on the machine.

For information on turning on the machine, refer to "Turning On the Machine".



- Confirm that [READY TO PRINT] is displayed on the machine.
- Press \wedge button or \vee button several times to display [ADMIN SETUP].
- Press OK button.
- When [ENTER PASSWORD] is displayed, enter the password.
 - ▶ The default password is "999999."
- When the password has been entered, press O» button.
- Press \wedge button or \vee button several times to display [OTHERS SETUP].
- Press OK button.
- Press \wedge button or \vee button several times to display [PRESENTER UNIT].
- Press OK button.
- With the setting flashing, press \wedge button or \vee button to display [ENABLE], and press OK button.
- The machine restarts and returns to the [READY TO PRINT] standby status.
 - ▶ For information on printing, refer to "Printing Using the Presenter Unit".

-
- Turning On or Off the Machine
 - About the Power Supply
 - Ensure the following conditions for the power supply.
 - CX86e: 110 to 127V AC (Range 99 to 140V AC)
 - CX86e: 220 to 240V AC (Range 198 to 264V AC)
 - Power frequency: 50/60 Hz \pm 2%

 If the power supply is unstable, use a voltage regulator. The maximum power consumption of the machine is 650W. Check that the power supply is sufficient. Operation is not guaranteed if an uninterruptible power supply (UPS) or inverter is used. Do not use an uninterruptible power supply (UPS) or inverter.

- Be sure to turn off the machine before connecting and disconnecting the power cord and the ground wire.
- Be sure to connect the ground wire to the designated ground terminal.
- If the machine cannot be grounded, contact your dealer.
Be sure not to connect the ground wire to a water pipe, a gas pipe, the ground terminal of a telephone line, or a lightning rod.
- Be sure to connect the ground wire before connecting the power cord to the outlet.
Also, be sure to unplug the power cord from the outlet before disconnecting the ground wire.
Be sure to hold the power plug when plugging in or unplugging the power cord.
- Be sure to insert the power cord fully into the power outlet.
Do not plug in or unplug the power cord with wet hands.
Install the power cord in a location where users cannot step on it, and do not place any object on the power cord.
- Do not bundle or tie the power cord
Do not use a damaged power cord.
- Do not overload the outlet.
- Do not connect the power cords of this machine and other electric products to the same outlet. If the power cord of this machine is connected to the same outlet as other electric products, especially an air conditioner, copier, or shredder, this machine may malfunction due to electrical noise. If you have to connect the power cord of this machine to the same outlet as other products, use a commercially available noise filter or noise cut transformer.
- Use the power cord included in this machine, and plug the cord directly into the outlet. Do not use the power cords of other products for this machine.
- Do not use an extension cord. If you have to use an extension cord, use a cord rated 10A or higher.
- If you use an extension cord, this machine may not work properly due to AC voltage drop.
- Do not turn off this machine or unplug the power cord while printing.
- If you do not use this machine for an extended period of time at occasions such as holidays or trips, unplug the power cord from the outlet.
- Do not use the power cord included in this machine for other products.

Turning On the Machine

Turning On the Machine

Connect the power cable to the power connector on the rear of the machine.

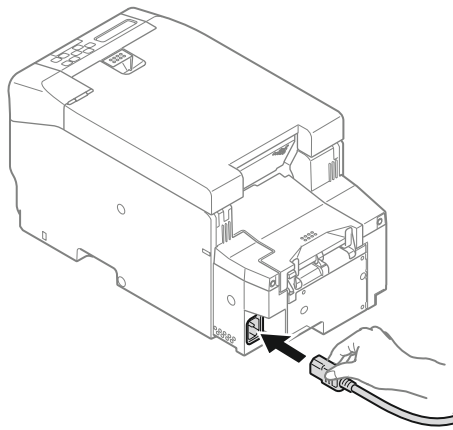

Insert the power plug into the outlet.

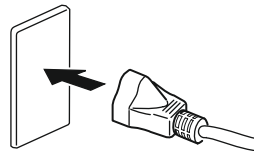

Open the cover on the front left of the machine and press and hold the power switch for approximately one second.

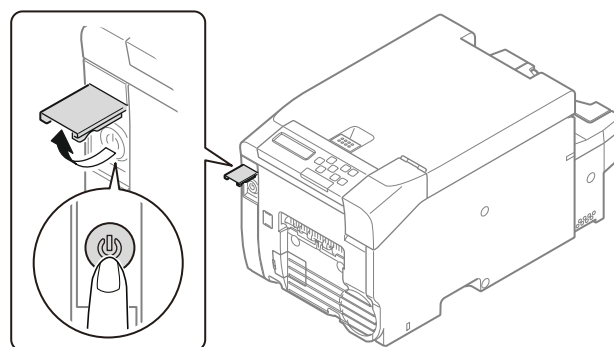

Turning Off the Machine

Open the cover on the front left of the machine and press and hold the power switch for one second.

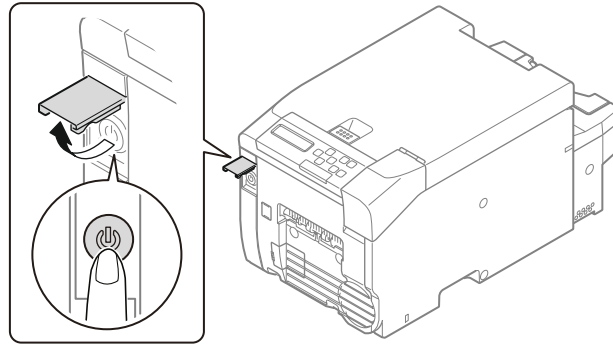

Wait until [SHUTTING DOWN. PLEASE WAIT/TURN OFF AUTOMATICALLY] is displayed on the operation panel and the operation panel turns off.

Remove the power plug from the outlet.

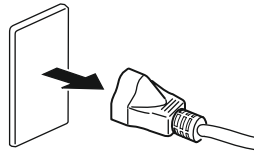

Remove the power cable from the power connector on the rear of the machine.

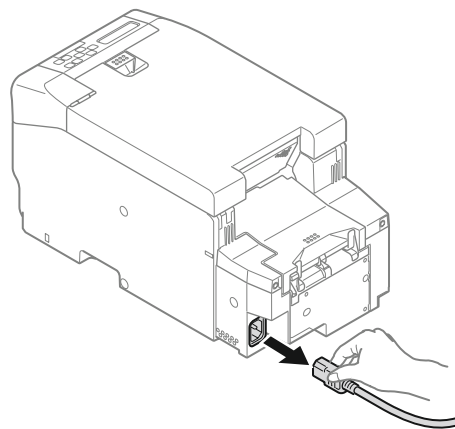

When you want to shutdown the machine forcefully, press and hold the power switch for more than 5 seconds.

Connecting a LAN Cable

A LAN cable can be used to connect the machine to a computer via a wired network.

Before installing the printer driver, connect the printer to the network using a LAN cable.

Prepare a LAN cable and hub.

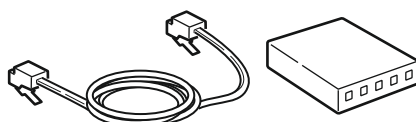

Make sure that the machine and the computer are turned off.

Insert the LAN cable into the network interface connector of the machine.

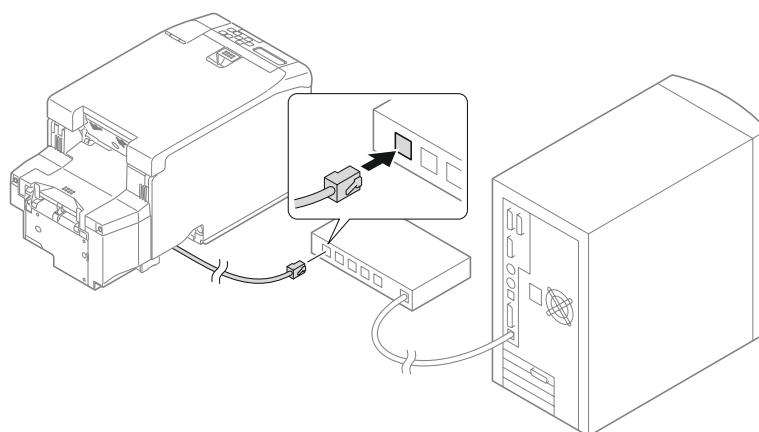

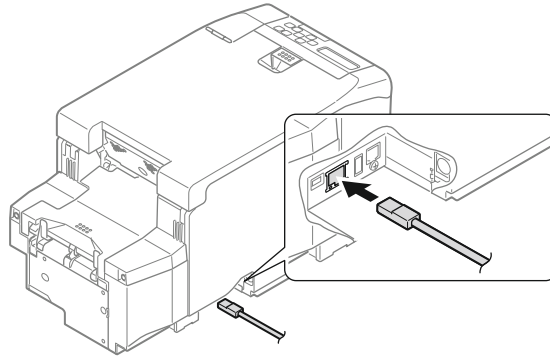

Insert the other end of the LAN cable into the hub.

Insert the LAN cable into the network interface connector of the hub.

Connecting via Wireless LAN

Preparing to Connect via Wireless LAN

Connecting via an Access Point

Check whether your wireless LAN access point supports the following environment.

- Standard: IEEE 802.11 a/b/g/n
- Access method: Infrastructure mode

Check whether the wireless LAN access point supports WPS.

If it does not support WPS, check the SSID and encryption key in the manual that came with the wireless LAN access point.

- The SSID may also be called the network name, ESSID, or ESS-ID.
- The encryption key may also be called the network key, security key, password, or pre-shared key (PSK).

Directly Connecting to the Machine

Check whether your wireless terminal supports the following environment.

- Standard: IEEE 802.11 b/g/n
- Security: WPA2-PSK (AES)

Check whether your wireless terminal supports WPS-PBC (push).

If you are not sure whether it supports WPS-PBC, turn the machine on and connect manually.

Connecting via an Access Point (Infrastructure)

To choose a valid default gateway.

- ▶ Press up or down on the operator panel to display [ADMIN SETUP].
- ▶ Press the OK button.

- ▶ Enter the Admin password, and then press the OK button.
- ▶ Press \wedge button or \vee button on the operator panel to display [NETWORK SETUP], and then press the OK button.
- ▶ Press \wedge button or \vee button on the operator panel to display [ENABLING DEFAULT GATEWAY], and then press the «OK» button.
- ▶ Press \vee button the operator panel to display [WIRELESS (INFRASTRUCTURE)], and then press the OK button.

Connecting Using WPS

If the wireless LAN access point supports WPS, the connection to the wireless LAN can be made easily by using the easy setup button (WPS button).

Follow the procedure below for the setup.

- Confirm the position of the easy setup button and when to press the button by referring to the user manual of the wireless LAN access point.
- Confirm that the wireless LAN access point has been activated and is functioning normally.
- Turn on the printer. When [SETUP WIRELESS?] appears, select [YES]. Proceed to Step 6.
- Press \wedge button or \vee button on the operator panel to display [WIRELESS SETTING], and then press the OK button.
- Enter the Admin password, and then press the OK button.
 - ▶ The default password is 999999.
- Press up on the operator panel to select [ENABLE], and then press the OK button.
- Press \wedge button or \vee button on the operator panel to display [WPS SETUP], and then press the OK button.
- Select [WPS-PBC], and then press the OK button.
- Select [YES], and then press the OK button.
- The Printer starts searching for wireless LAN access points. During 2 minutes, press the easy setup button for the wireless LAN access point for a few seconds.

Once the setup completion screen is displayed, it indicates that the wireless LAN setup has completed.

Set the IP Address

Set a different IP address for the wireless LAN from that of the wired LAN. Enter the setting menu and make the settings by the following procedure.

- Press \wedge button or \vee button on the operator panel to display [WIRELESS SETTING], and then press the OK button.
- Enter the Admin password and then press the OK button.
 - ▶ The default password is 999999.
- Press \wedge button or \vee button on the operator panel to display [NETWORK SETTING], and then press the OK button.

- Press OK button when [IP ADDRESS SET] is displayed.
- Press ^ button or v button on the operator panel to select [AUTO] or [MANUAL].
If [MANUAL] is selected, manually input the IPv4 Address, Subnet Mask and Gateway Address.

Directly Connecting to the Machine (AP Mode)

Automatic Setup (Push Button)

If the wireless terminal (computer, tablet, smartphone, etc.) supports «WPS-PBC» (push button), then you can use the WPS button to connect via wireless (AP mode).

Follow the procedure below to connect.

- Confirm the position of the WPS button in the user's manual provided with the wireless terminal (computer, tablet, smartphone, etc.).
- Turn on the printer.
When [SETUP WIRELESS?] appears, select [NO].
- Press ^ button or v button on the operator panel to display [WIRELESS (AP MODE) SETTING], and then press the OK button.
- Enter the Admin password, and then press the OK button.
 - ▶ The default password is 999999.
- Select [ENABLE], and then press the OK button.
- Press ^ button or v button on the operator panel to display [AUTOMATIC SETUP (PUSHBUTTON)], and then press the OK button.
- Select YES, and then press the OK button.
- Start WPS-PBC (push button) on the wireless terminal (computer, tablet, smartphone, etc.).

Once the setup completion screen is displayed, it indicates that the wireless LAN setup has completed.

Using Both a Wired LAN and Wireless LAN Connection

The machine can use both a wired LAN and wireless LAN connection at the same time. The available combinations are indicated in the table below



-  Wireless LAN (infrastructure) and wireless LAN (AP mode) cannot be enabled at the same time.
- When wired LAN and wireless LAN are connected to the same subnet, communication may become unstable.

Yes: Enabled, No: Disabled

	Connected with LAN Cable	Wireless LAN (Infrastructure)	Wireless LAN (AP Mode)
Available Combinations	Yes	Yes	No
	Yes	No	Yes

Connecting a USB Cable

A USB cable is not included with the machine. Prepare an A-B type cable separately.

- ▶ For Windows, do not insert the other end of the USB cable into the computer until an instruction appears on the screen during the printer driver installation.
- Prepare a USB cable.
- Make sure that the machine and the computer are turned off.
- Insert the B end of the USB cable into the USB interface connector of the machine.
- ▶ Do not insert the USB cable into the network interface connector. Doing so may cause a malfunction.

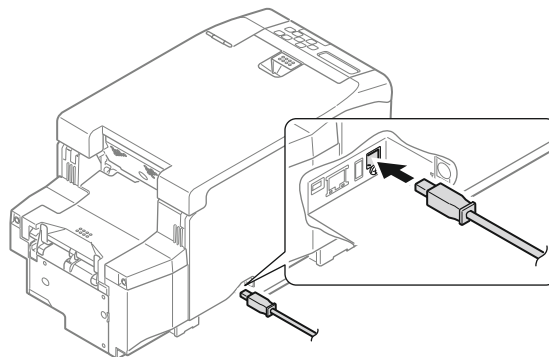

- Insert the A end of the USB cable into the USB interface connector of the computer.
- ▶ For Windows, do not insert the other end of the USB cable into the computer until an instruction appears on the screen during the printer driver installation.

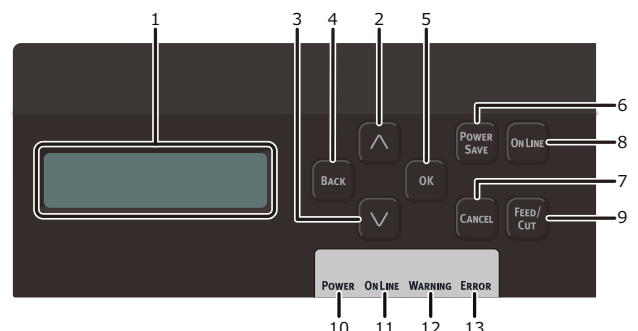
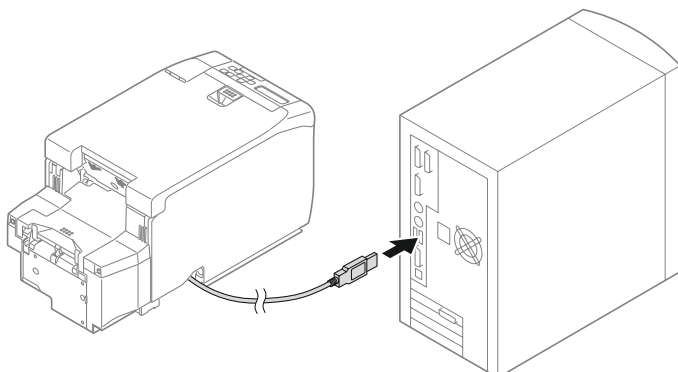

Installing the Printer Driver to a Computer

See separate instructions which came with the download of the printer driver.

Name and Function

No.	Name	Description
1	LCD	Displays the status of the machine and the menu items. Turns off when the machine is in the Power Save mode.
2	^ Button	Enters the Menu mode. Returns to the previous item when the machine is in the Menu mode. Press and hold it for 1 second or more to skip forward.
3	∨ Button	Enters the Menu mode. Proceeds to the next item when the machine is in the Menu mode. Press and hold it for 1 second or more to skip forward.
4	«BACK» Button	Returns to the previous screen.
5	«OK» Button	Confirms the selected item. Or confirms the set value.
6	«POWER SAVE» Button	Enters the Power Save mode. Or cancels the Power Save mode. Lights red when the machine is in the Power Save mode.
7	«CANCEL» Button	Stops an operation or cancels a setting.
8	«ONLINE» Button.	Switches the machine online/offline.
9	«FEED/CUT» Button	Cuts, ejects, and feeds the paper.
10	POWER LED	Lights up when the power of the machine is on. However, flashes when the machine is in the Sleep mode.
11	ONLINE LED	Lights up when the machine is online (when printing can be performed).
12	WARNING LED	Lights up when an error has occurred in the machine. Printing is possible.
13	ERROR LED	Flashes when an error has occurred in the machine.

Description of the Display

The display indicates the status of the machine and the menu items, etc.

When Printing Can Be Performed

When the machine can perform printing, [READY TO PRINT] is displayed on the top of the screen.

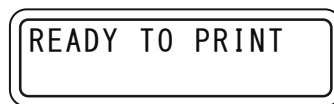

A rectangular display box with a double border containing the text "READY TO PRINT".

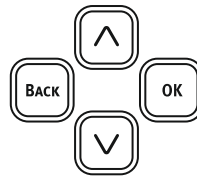

When an Error Has Occurred in the Machine

Top: Displays the solution.

Bottom: Displays the error code and error type.

For information on errors and solutions, refer to "9. Troubleshooting".



A rectangular display box with a double border containing the text "REPLACE TONER" on the top line and "412: TONER EMPTY" on the bottom line.

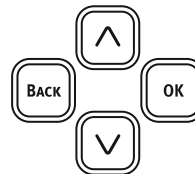

When the Machine Is in the Menu Mode

Top: Displays the category or item.

Bottom: Displays the setting when an item is displayed on the top.



A rectangular display box with a double border containing the text "POW SAVE TIME" on the top line, "1MIN" on the bottom line, and an asterisk "*" on the far right of the bottom line.

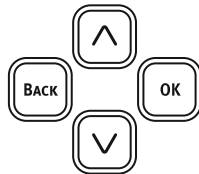

The menu depth (level) is also displayed with [>].

When [>] or [>>] is displayed, there are items in a lower level.

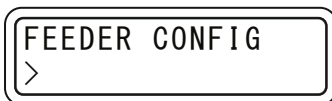

A rectangular display box with a double border containing the text "FEEDER CONFIG" on the top line and a right-pointing chevron ">" on the bottom line.

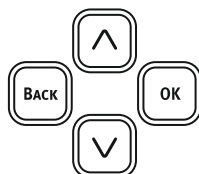

For details on menu items, refer to "Menu List".

Entering and Viewing the Menu

Confirm that [READY TO PRINT] is displayed on the machine.

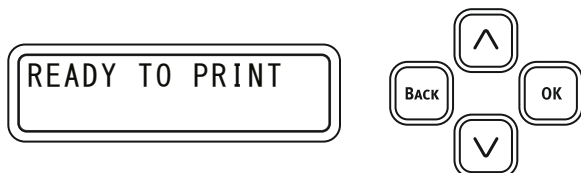

Press \wedge button or \vee button to enter the Menu mode and display the menu categories.

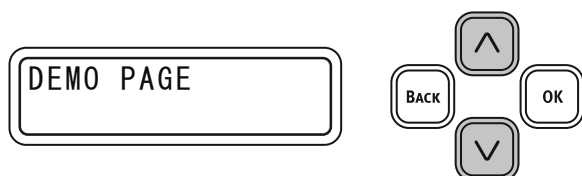

Press \wedge button or \vee button several times to display the category you want to set, and press «OK» button.

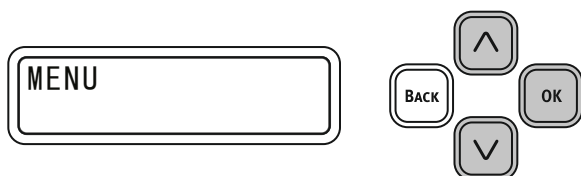

Display the lower menu categories. The [>] indicating the menu depth is displayed on the bottom of the screen.

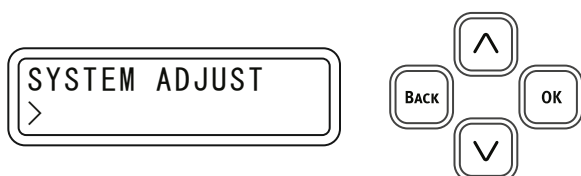

Press \wedge button or \vee button several times to display the category you want to set, and press «OK» button.

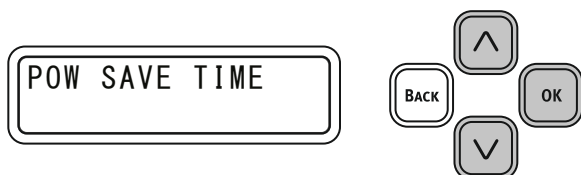

- [>>] is displayed on the bottom of the screen if there are more lower menu categories.

When an item is displayed on the top and a setting is displayed on the bottom, press «OK» button to make the setting flash and become changeable. Press «^» button or «v» button several times to display the value you want to set, and press «OK» button.

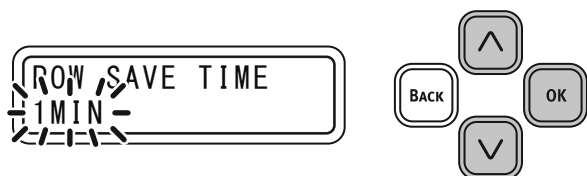

"*" is displayed on the right edge of the setting.

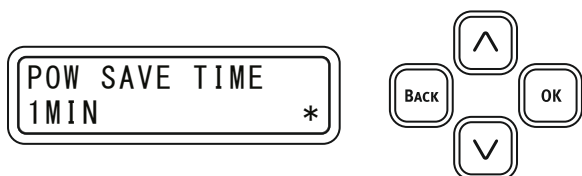

To end the Menu mode, press «ONLINE» button, or press «BACK» button until "READY TO PRINT" is displayed.

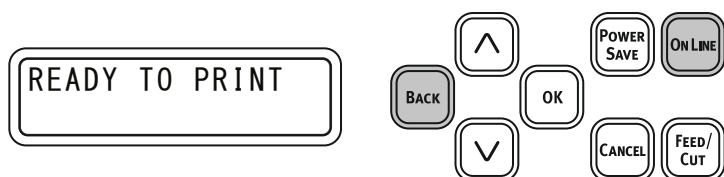

Entering Characters

When the screen for entering the password, etc. is displayed, press \wedge button or \vee button to select the character to enter.

- Press \wedge button to display characters starting with lower case letters.
 - ▶ The characters are displayed in the following order: lower case letters \rightarrow symbols \rightarrow upper case letters \rightarrow numbers (0 to 9)
- Press \vee button to display the characters in reverse order.
 - ▶ Numbers (9 to 0) \rightarrow upper case letters in reverse \rightarrow ...

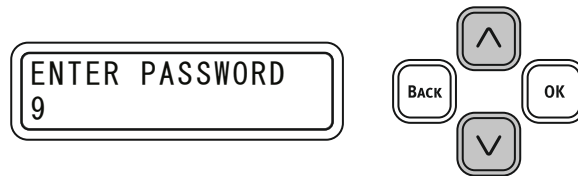

Press OK button to confirm the selected character.

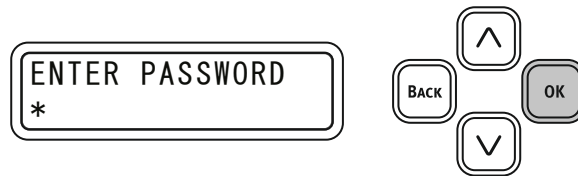

The cursor moves to the next digit.

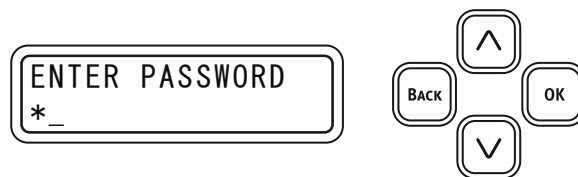

Perform the same operation to enter the rest of the characters, and press OK button when all the characters have been entered.

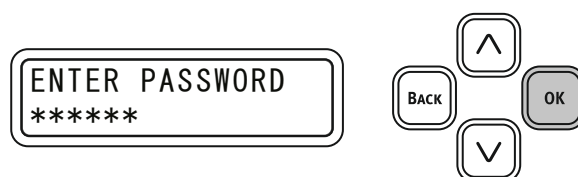

Printing a Demonstration Page

Use cut sheet cut to the following size or continuous paper (roll paper) without a mark. The operation is not guaranteed for other paper.

- When printing on cut sheet
 - ▶ Prepare paper that is 74 mm wide and 210 mm long.
 - ▶ Print after setting [MENU] > [FEEDER CONFIG] > [PAPER FORM] > [CUT PAPER].
- When printing on continuous paper (roll paper)
 - ▶ Prepare continuous paper (roll paper) without a mark that is 74 mm to 86 mm wide.
 - ▶ Print after setting [MENU] > [FEEDER CONFIG] > [PAPER FORM] > [CONTINUOUS PAPER] and [MENU] > [FEEDER CONFIG] > [CUT TYPE] > [LENGTH].
- Confirm that [READY TO PRINT] is displayed on the machine.
- Load the paper.
- Press \wedge button or \vee button to display [DEMO PAGE].
- Press OK button.
- Press OK button when [DEMO1/EXECUTE] is displayed.

Adjusting the Volume

A buzzer notifies the user when an error has occurred in the machine or printing has finished.

By default, the machine is set to sound the buzzer when the paper has run out.

This section describes how to change the volume and set whether to sound the buzzer.

Setting the Volume

Available values high, low, and off.

Low is set by default.

- Confirm that [READY TO PRINT] is displayed on the machine.
- Press \wedge button or \vee several times to display [ADMIN SETUP].
- Press OK button.
- When [ENTER PASSWORD] is displayed, enter the password.
 - ▶ The default password is "999999."

- When the password has been entered, press OK button.
- Press \wedge button or \vee button several times to display [BUZZER SETUP].
- Press OK button.
- Press OK button when [ERROR VOLUME] is displayed.
- With the setting flashing, press \wedge button or \vee button to display the value you want to set, and press OK button.
- Confirm that "*" is displayed to the right of the value you want to set.
- Press «ONLINE» button to return to the [READY TO PRINT] standby status.

Setting the Volume for the Printing Complete Buzzer

The buzzer volume can be set to high, low, or off, and is set to off by default.

If the buzzer volume is set to high or low, the buzzer sounds each time a page is printed by default, regardless of the page count of the print data. You can change the buzzer to sound when printing is complete for all the pages of the print data.

- Confirm that [READY TO PRINT] is displayed on the machine.
- Press \wedge button or \vee button several times to display [ADMIN SETUP].
- Press «OK» button.
- When [ENTER PASSWORD] is displayed, enter the password.
 - ▶ The default password is "999999."
- When the password has been entered, press «OK» button.
- Press \wedge button or \vee button several times to display [BUZZER SETUP].
- Press «OK» button.
- Press \wedge button or \vee button several times to display [PRINT COMPLETION VOLUME].
- Press «OK» button.
- With the setting flashing, press \wedge button or \vee button to display the value you want to set, and press «OK» button.
- Confirm that "*" is displayed to the right of the value you want to set.
- If [OFF] is set, proceed to the last step.
- If [LOW] or [HIGH] is set, press \vee button once to display [PRINT COMPLETION BUZZER].
- Press «OK» button.
- With the setting flashing, press \wedge button or \vee button to display the value you want to set, and press «OK» button.
- Confirm that "*" is displayed to the right of the value you want to set.
- Press «ONLINE» button to return to the [READY TO PRINT] standby status.

Checking Information About the Machine

Printing and Checking a Report

-  Perform the procedure below to print and check the values set in the machine.
- Use cut sheet cut to the following size or continuous paper (roll paper) without a mark. The operation is not guaranteed for other paper.
 - ▶ When printing on cut sheet
 - ▶ Prepare paper that is 74 mm wide and 210 mm long.
 - ▶ You can print on A4 or LETTER paper that has been cut to a quarter of its long side.
 - ▶ Print after setting [MENUS] > [FEEDER CONFIG] > [PAPER FORM] > [CUT PAPER].
 - ▶ When printing on continuous paper (roll paper)
 - ▶ Prepare continuous paper (roll paper) without a mark that is 74 mm to 86 mm wide.
 - ▶ Print after setting [MENUS] > [FEEDER CONFIG] > [PAPER FORM] > [CONTINUOUS PAPER] and [MENUS] > [FEEDER CONFIG] > [CUT TYPE] > [LENGTH].
- Confirm that [READY TO PRINT] is displayed on the machine.
- Press \wedge button or \vee button to display [PRINT INFO].
- Press «OK» button.
- Press «OK» button when [CONFIGURATION/EXECUTE] is displayed.
- Load the paper displayed on the screen in the machine.
- Press «OK» button.

Checking the Operation Panel

You can check the print count, remaining consumables, network settings, and machine information on the operation panel.

- Confirm that [READY TO PRINT] is displayed on the machine.
- Press \wedge button or \vee button several times to display [CONFIGURATION].
- Press «OK» button to display the print count.
- To also check the remaining consumables, network settings, or machine information, press \wedge button or \vee button to display the item you want to check, and press «OK» button.
- Press \wedge button or \vee button to check each value.
- When you have finished checking, press «ONLINE» button, or press «BACK» button until [READY TO PRINT] is displayed.

Setting the Power Save Mode Transition Time

The machine enters the Power Save mode when it has not been used for a certain period of time. 0 minutes is set by default.

- Confirm that [READY TO PRINT] is displayed on the machine.
- Press \wedge button or \vee button several times to display [MENUS], and press «OK» button.
- Press \wedge button or \vee button several times to display [SYSTEM ADJUST], and press «OK» button.
- Press «OK» button when [POW SAVE TIME] is displayed.
- With the setting flashing, press \wedge button or \vee button to display the value you want to set, and press «OK» button.
- Confirm that "*" is displayed to the right of the value you want to set.
- Press «ONLINE» button to return to the [READY TO PRINT] standby status.

Setting the Sleep Mode Transition Time

If the machine is not used for a certain period of time after it enters the Power Save mode, the machine enters the Sleep mode. 15 minutes is set by default.

- Confirm that [READY TO PRINT] is displayed on the machine.
- Press \wedge button or \vee button several times to display [MENUS], and press «OK» button.
- Press \wedge button or \vee button several times to display [SYSTEM ADJUST].
- Press «OK» button.
- Display [POW SAVE TIME].
- Press \vee button once to display [SLEEP TIME], and press «OK» button.
- With the setting flashing, press \wedge button or \vee button to display the value you want to set, and press «OK» button.
- Confirm that "*" is displayed to the right of the value you want to set.
- Press «ONLINE» button to return to the [READY TO PRINT] standby status.

Precautions for the Power Save Function

The machine does not enter the Sleep mode in the following cases.

- When an error has occurred in the machine

The machine does not enter the Power Save mode in the following cases.

- When paper is remained in the Presenter Unit

Setting the Auto Power Off Time

If the machine is not used for a certain period of time, it automatically turns off.

By default, the machine does not automatically turn off. To make the machine automatically turn off, enable the Auto Power Off setting on the operation panel, and then set the time until the power turns off. 4 hours is set by default.

Enabling Auto Power Off

- Confirm that [READY TO PRINT] is displayed on the machine.
- Press \wedge button or \vee button several times to display [ADMIN SETUP], and press «OK» button.
- Press \wedge button or \vee button several times to display [POWER SETUP].
- Press «OK» button.
- Display [AUTO PW OFF].
- Press \wedge button or \vee button several times to set to [ENABLE] or [AUTO CONFIG], and press «OK» button.
- Press «ONLINE» button, or press «BACK» button until [READY TO PRINT] is displayed.

Setting the Time Until Auto Power Off

- Confirm that [READY TO PRINT] is displayed on the machine.
- Press \wedge button or \vee button several times to display [MENUS], and press «OK» button.
- Press \wedge button or \vee button several times to display [SYSTEM ADJUST].
- Press «OK» button.
 - ▶ Display [POW SAVE TIME].
- Press \wedge button or \vee button several times to display [AUTO PW OFF TIME], and press «OK» button.
- With the setting flashing, press \wedge button or \vee button to display the value you want to set, and press «OK» button.
- Press «ONLINE» button, or press «BACK» button until [READY TO PRINT] is displayed.

Initializing the Flash Memory

When you initialize the flash memory, the following data is deleted.

- ▶ Form data
- ▶ Download demo print data
- ▶ Saved menu settings
- Confirm that [READY TO PRINT] is displayed on the machine.
- Press \wedge button or \vee button several times to display [ADMIN SETUP].
- Press «OK» button.
- When [ENTER PASSWORD] is displayed, enter the password.
 - ▶ The default password is "999999."
- When the password has been entered, press «OK» button.
- Press \wedge button or \vee button several times to display [OTHERS SETUP], and press «OK» button.
- Press \wedge button or \vee button several times to display [STORAGE SETUP], and press «OK» button.
- [ENABLE INITIAL] is displayed. If [NO *] is displayed on the bottom, proceed to step 9. If [YES *] is displayed on the bottom, proceed to step 10.
- The bottom flashes when «OK» button is pressed. Press \vee button to display [YES] on the bottom, and press «OK» button. (The flashing stops and [YES *] is displayed.)
- Press «BACK» button once to display [STORAGE SETUP]. Press \wedge button once to display [FLASH SETUP], and press «OK» button.
- Press «OK» button when [FLASH INITIALIZE / EXECUTE] is displayed.
- When the confirmation message is displayed, press \wedge button or \vee button to display [YES] or [NO], and press «OK» button.
- If you selected [NO], the machine returns to the previous screen.
If you selected [YES], a confirmation message is displayed again.
- If you selected [NO], the previous screen is displayed again, but since the machine remembers that it needs to initialize the flash memory, the flash memory is initialized the next time that the power is turned on.
If you selected [YES], the machine automatically restarts and the flash memory is initialized.

-
- Confirm that [READY TO PRINT] is displayed on the machine.
 - Press ^ button or v button several times to display [ADMIN SETUP].
 - Press «OK» button.

 - When [ENTER PASSWORD] is displayed, enter the password.
 - ▶ The default password is "999999."
 - When the password has been entered, press «OK» button.
 - Press ^ button or v button several times to display [OTHERS SETUP], and press «OK» button.
 - Press ^ button or v button several times to display [STORAGE SETUP], and press «OK» button.
 - [ENABLE INITIAL] is displayed. If [NO *] is displayed on the bottom, proceed to step 9. If [YES *] is displayed on the bottom, proceed to step 10.
 - The bottom flashes when «OK» button is pressed. Press v button to display [YES] on the bottom, and press «OK» button. (The flashing stops and [YES *] is displayed.)
 - Press «BACK» button once to display [STORAGE SETUP]. Press ^ button once to display [FLASH SETUP], and press «OK» button.
 - Press «OK» button when [FLASH INITIALIZE / EXECUTE] is displayed.
 - When the confirmation message is displayed, press ^ button or v button to display [YES] or [NO], and press «OK» button.
 - If you selected [NO], the machine returns to the previous screen.
If you selected [YES], a confirmation message is displayed again.
 - If you selected [NO], the previous screen is displayed again, but since the machine remembers that it needs to initialize the flash memory, the flash memory is initialized the next time that the power is turned on.
If you selected [YES], the machine automatically restarts and the flash memory is initialized.

Initializing the Network Settings

The default network settings can be restored.

- Confirm that [READY TO PRINT] is displayed on the machine.
- Press ^ button or v button several times to display [ADMIN SETUP].
- Press «OK» button.

- When [ENTER PASSWORD] is displayed, enter the password.
 - The default password is "999999."
- When the password has been entered, press «OK» button.
- Press «OK» button when [NETWORK SETUP] is displayed.
- Press ^ button or v button several times, and press «OK» button when [FACTORY DEFAULTS/EXECUTE] is displayed.

Initializing the Settings of the Machine

The default settings of the machine can be restored. When this operation is performed, the machine automatically restarts.

- Confirm that [READY TO PRINT] is displayed on the machine.
- Press \wedge button or \vee button several times to display [ADMIN SETUP].
- Press «OK» button.
- When [ENTER PASSWORD] is displayed, enter the password.
 - ▶ The default password is "999999."
- Press \wedge button or \vee button several times to display [SETTINGS].
- Press «OK» button.
- Press «OK» button when [MENU RESET/EXECUTE] is displayed.
- Wait until [READY TO PRINT] is displayed on the screen after the device restarts.

Changing the Administrator Password

This section describes the method for changing the administrator password. It is recommended that the default password is changed for increased security.

Set 6 to 12 digits for the password. Numbers and lower case letters can be used for the password.

- Confirm that [READY TO PRINT] is displayed on the machine.
- Press \wedge button or \vee button several times to display [ADMIN SETUP].
- Press «OK» button.
- When [ENTER PASSWORD] is displayed, enter the password.
 - ▶ The default password is "999999."
- When the password has been entered, press «OK» button.
- Press \wedge button once to display [CHANGE PASSWORD].
- Press «OK» button.
- When [NEW PASSWORD] is displayed, enter the new password.
- When the confirmation screen is displayed, enter the same password.
- The password change is complete when [CHANGE PASSWORD] is displayed.
- Press «ONLINE» button to return to the [READY TO PRINT] standby status.

Correcting the Color Density

This section describes the procedure for correcting the density on the operation panel.

- Confirm that [READY TO PRINT] is displayed on the machine.
- Press \wedge button or \vee button several times to display [CALIBRATION], and press «OK» button.
- Press \vee button once to display [ADJUST DENSITY/EXECUTE].
- Press «OK» button.
- The procedure is complete when [READY TO PRINT] is displayed on the screen.

Adjusting the Color Balance (Density)

You can adjust the cyan, magenta, and yellow highlights (light areas), intermediate areas, and dark areas.

This section describes the procedure for adjusting cyan. If you want to adjust other colors, perform the same operation for those colors.

- Confirm that [READY TO PRINT] is displayed on the machine.
- Press \wedge button or \vee button several times to display [CALIBRATION], and press «OK» button.
- Press \wedge button or \vee button several times to display [CYAN TUNING], and press «OK» button.
- Press \wedge button or \vee button several times to display [CYAN HIGHLIGHT] (light areas), [CYAN MID-TONE] (intermediate areas), or [CYAN DARK] (dark areas), and press «OK» button.
- With the setting flashing, press \wedge button or \vee button to display the value you want to set, and press «OK» button. Positive values are darker and negative values are lighter.
- Confirm that "*" is displayed to the right of the value you want to set.
- Press «ONLINE» button to return to the [READY TO PRINT] standby status.

Correcting Color Shift

This section describes the procedure for correcting color shift on the operation panel.

- Confirm that [READY TO PRINT] is displayed on the machine.
- Press \wedge button or \vee button several times to display [CALIBRATION], and press «OK» button.
- Press \wedge button or \vee button several times to display [ADJUST REGISTRATION/EXECUTE].
- Press «OK» button.
- The procedure is complete when [READY TO PRINT] is displayed on the screen.

Adjusting the Paper Sensors (Sensor Calibration)

If paper jams or paper mark detection errors occur frequently, follow the procedure below to perform sensor calibration.

 For the paper with black mark, cut it so that the black mark is at the leading edge of the paper, and then load it.

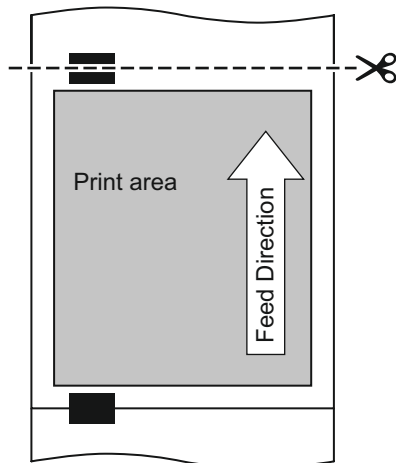

- The paper sensors are adjusted to the position suitable for the paper to use.

 ▶ Adjust the paper sensors to a suitable position, as they cannot be correctly calibrated unless they are in a suitable position.

▶ For details, refer to "Setting the Paper Sensors".

- Confirm that [READY TO PRINT] is displayed on the machine.
- Press \wedge button or \vee button several times to display [MENUS], and press «OK» button.
- Press \wedge button or \vee button to display [SENSOR CONFIG], and press «OK» button.
- Press «OK» button when [SENSOR CALIBRATION/EXECUTE CALIBRATION] is displayed.
- When [PLEASE REMOVE PAPER/YES] is displayed, remove the paper from the machine.
- With [YES] flashing, press «OK» button.
- Load the paper in the machine when [PLEASE LOAD PAPER] is displayed.
- The procedure is complete when [READY TO PRINT] is displayed.

Menu List

This section describes the menu items that can be set on the operation panel.

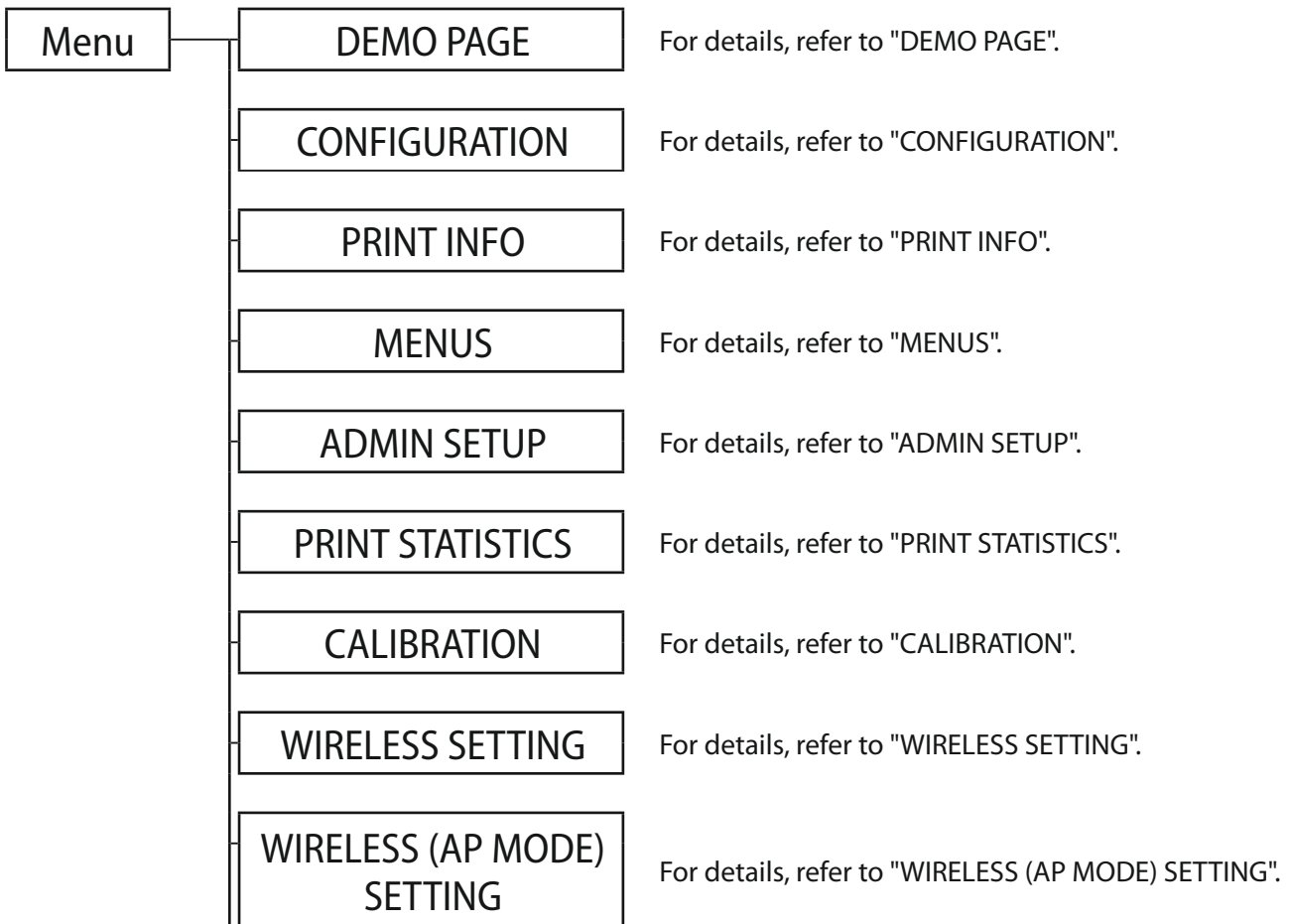

DEMO PAGE

Item	Setting	Description
DEMO1 ...	EXECUTE	Prints a demonstration page.

CONFIGURATION

Enables you to check the information of the machine.

Item	Setting	Description		
PRINT COUNT	nnnnnn	Displays the print count.		
SUPPLIES LIFE	DRUM UNIT LIFE	REMAINING nnn%		
	BELT LIFE	REMAINING nnn%		
	FUSER LIFE	REMAINING nnn%		
	TONER (n.nK)	REMAINING nnn%		
NETWORK (*When the Wireless LAN Module is not installed)	PRINTER NAME	CX86e		
	SHORT NAME	CX86e		
	IPV4 ADDRESS	xxx.xxx.xxx.xxx		
	SUBNET MASK	xxx.xxx.xxx.xxx		
	GATEWAY ADDRESS	xxx.xxx.xxx.xxx		
	MAC ADDRESS	xx:xx:xx:xx:xx:xx		
	NETWORK VERSION	xx.xx		
	WEB VERSION	xx.xx		
	IPV6 LOCAL	xxxx:xxxx:xxxx:xxxx: xxxx:xxxx:xxxx:xxxx		
	IPV6 STATELESS	xxxx:xxxx:xxxx:xxxx: xxxx:xxxx:xxxx:xxxx		
IPV6 STATEFUL	xxxx:xxxx:xxxx:xxxx: xxxx:xxxx:xxxx:xxxx			
NETWORK (*When the Wireless LAN Module is installed)	NETWORK INFO	PRINTER NAME	***** *****	Displays the machine name.
		SHORT NAME	*****	Displays the short name.
		ENABLING DEFAULT GATEWAY	WIRED WIRELESS (INFRASTRUCTURE)	Displays the enabled default gateway.
		WIRED	ENABLE DISABLE	Displays whether wired LAN is enabled or disabled.
		IPV4 ADDRESS	xxx.xxx.xxx.xxx	Displays the IPv4 address.
		SUBNET MASK	xxx.xxx.xxx.xxx	Displays the subnet mask.
		GATEWAY ADDRESS	xxx.xxx.xxx.xxx	Displays the gateway address.
		MAC ADDRESS	xx:xx:xx:xx:xx:xx	Displays the MAC address.
		NETWORK VERSION	xx.xx	Displays the version of the network firmware of the machine.
		WEB VERSION	xx.xx	Displays the version of the Web page of the machine.
		IPV6 LOCAL	xxxx:xxxx:xxxx:xxxx: xxxx:xxxx:xxxx:xxxx	Displays the IPv6 address.
		IPV6 STATELESS	xxxx:xxxx:xxxx:xxxx: xxxx:xxxx:xxxx:xxxx	Displays the IPv6 address (stateless).
IPV6 STATEFUL	xxxx:xxxx:xxxx:xxxx: xxxx:xxxx:xxxx:xxxx	Displays the IPv6 address (stateful).		

Item	Setting	Description	
WIRELESS (INFRASTRUCTURE) INFO	FW VERSION	Displays the version of the wireless LAN firmware.	
	WIRELESS (INFRASTRUCTURE)	ENABLE DISABLE	Displays whether wireless (infrastructure) is enabled or disabled.
	SSID		Displays the SSID of the connection destination.
	SECURITY	DISABLE WEP WPA/WPA2-PSK WPA2-PSK WPA/WPA2-EAP *1 WPA2-EAP *2	Displays the type of security for the wireless LAN function.
	*1: Can only be set for the Web		
	*2: Can only be set for the Web		
	STATE	STARTED SCANNING CONNECTED DISABLE	Displays the connection status of wireless LAN.
	BAND	2.4 GHz (B), (B+G) (B+G+N), (G), (N), (B/G/N) 2.4 GHz 5.0 GHz (A+N), (A), (N), (A/N) 5.0 GHz	Displays the bandwidth being used.
	CHANNEL		Displays the channel number being used.
	RSSI		Displays the reception signal strength as a percentage.
	IPV4 ADDRESS	xxx.xxx.xxx.xxx	Displays the IPv4 address.
	SUBNET MASK	xxx.xxx.xxx.xxx	Displays the subnet mask.
	GATEWAY ADDRESS	xxx.xxx.xxx.xxx	Displays the gateway address.
	MAC ADDRESS	xx:xx:xx:xx:xx:xx	Displays the MAC address.
	IPV6 LOCAL	xxxx:xxxx:xxxx:xxxx: xxxx:xxxx:xxxx:xxxx	Displays the IPv6 address (local).
	IPV6 STATELESS	xxxx:xxxx:xxxx:xxxx: xxxx:xxxx:xxxx:xxxx	Displays the IPv6 address (stateless address).
	IPV6 STATEFUL	xxxx:xxxx:xxxx:xxxx: xxxx:xxxx:xxxx:xxxx	Displays the IPv6 address (stateful address).
WIRELESS (AP MODE) INFO	WIRELESS (AP MODE)	ENABLE DISABLE	Displays whether wireless (AP mode) is enabled or disabled.
	SSID		Displays the SSID of the connection destination.
	PASSWORD		Displays the password.
	CONNECTED DEVICES		Displays the number of connected devices.
	IPV4 ADDRESS	xxx.xxx.xxx.xxx	Displays the IPv4 address.

Item		Setting	Description
SYSTEM	SERIAL NUMBER	XXXXXXXXXXXXXXXXXXXX XXXXXXXX	Displays the serial number of the printer.
	ASSET NUMBER	XXXXXXXXXXXXXXXXXXXX XXXXXXXXXXXXXXXX	Displays the asset number of the printer.
	LOT NUMBER	XXXXXXXXXXXXXXXXXXXX XXXXXXXX	Displays the lot number of the machine.
	FW VERSION	xxx.xx_x_x	Displays the firmware version.
	CU VERSION	xx.xx	Displays the firmware version of the control unit.
	PU VERSION	xx.xx.xx	Displays the firmware version of the print unit.
	RAM	xxMB	Displays the size of the RAM in the machine.
	FLASH MEMORY	xxMB [Fxx]	Displays the size of the flash memory in the machine.

PRINT INFO

Information related to the device can be printed.

Item	Setting	Description
CONFIGURATION	EXECUTE	Prints information about the printer configuration.
PRINT FILE LIST	EXECUTE	Prints a file list.
PRINT ERROR LOG	EXECUTE	Prints an error log.

MENUS

Settings related to printing and the operation of the machine.

Item		Setting	Description
FEEDER CONFIG	PAPER FORM	CONTINUOUS PAPER CUT PAPER	Sets the paper format.
	X DIMENSION	1.00 IN / 25.0 MM ~ 2.91 IN / 74.0 MM ~ 3.40 IN / 86.0 MM	Sets the paper width.
	Y DIMENSION	2.10 IN / 53.0 MM ~ 8.27 IN / 210.0 MM ~ 21.70 IN / 551.0 MM	Sets the paper length.
	MEDIATYPE	PLAIN USERTYPE1 USERTYPE2 USERTYPE3 USERTYPE4 USERTYPE5	Sets the paper type. *USERTYPE1 to 5 are displayed if they are registered.
	MEDIAWEIGHT	LIGHT MEDIUM LIGHT MEDIUM MEDIUM HEAVY HEAVY ULTRA HEAVY1 ULTRA HEAVY2	Sets the paper weight.
	CUT TYPE	B/M(FRONT) B/M(BACK) SIDE HOLE CENTER HOLE NOTCH GAP LENGTH	Set the type of mark used for cutting the paper.
	GAP LENGTH	0.12 IN / 3.0 MM ~ 0.51 IN / 13.0 MM	It is not necessary to change this when printing on plain paper.
	CUT POSITION SET	-0.25 IN / -6.5 MM ~ 0.00 IN / 0.0 MM ~ +21.70 IN / +551.0 MM	Sets the position to cut paper with a black mark.
		-0.25 IN / -6.5 MM ~ 0.00 IN / 0.0 MM ~ +0.25 IN / +6.5 MM	Sets the position to cut paper with a hole and paper with a gap.
SENSOR CONFIG	SENSOR CALIBRA- TION	EXECUTE CALIBRATION	Adjusts the paper sensors.

Item	Setting	Description
SYSTEM ADJUST	POW SAVE TIME 0 MIN 1 MIN 2 MIN 3 MIN 4 MIN 5 MIN 10 MIN 15 MIN 30 MIN 60 MIN	Sets the time until the machine enters the Power Save mode.
	SLEEP TIME 1 MIN 2 MIN 3 MIN 4 MIN 5 MIN 10 MIN 15 MIN 30 MIN 60 MIN	Sets the time until the machine enters the Sleep mode from the Power Save mode.
	AUTO PW OFF TIME 1 HOUR 2 HOURS 3 HOURS 4 HOURS 8 HOURS 12 HOURS 18 HOURS 24 HOURS	Sets the time until the power is automatically turned off.
	CLRABLE WARNING OK BUTTON JOB END	Sets the timing for erasing warning errors that the machine can recover from.
	AUTO CONTINUE ON OFF	Sets whether to automatically recover the printer when a memory overflow is displayed. The waiting time until recovery is 15 seconds.
MANUAL TIMEOUT OFF 30 SEC 60 SEC	Sets the time until paper is loaded. Printing cannot be performed unless paper is loaded within this time.	

Item		Setting	Description
	TIMEOUT INJOB	OFF 5 SEC 10 SEC 20 SEC 30 SEC 40 SEC 50 SEC 60 SEC 90 SEC 120 SEC 150 SEC 180 SEC 210 SEC 240 SEC 270 SEC 300 SEC	Sets the time until forced printing is performed when print data stops being received.
	TIMEOUT LOCAL	0 SEC 5 SEC ~ 40 SEC ~ 290 SEC 295 SEC 300 SEC	Sets the time that the ports are left open when an operation finishes. (Excluding the network ports.)

Item		Setting	Description	
	TIMEOUT NET	0 SEC 5 SEC ~ 90 SEC ~ 290 SEC 295 SEC 300 SEC	Sets the time that the network ports are left open when an operation finishes.	
	JAM RECOVERY	ON OFF	Sets whether to print the page where a paper jam occurred again. When this is set to OFF, the remaining pages are not printed, including the page where the paper jam occurred.	
	ERROR REPORT	ON OFF	Sets whether to print an error report when an error occurs in the printer.	
	HEX DUMP	EXECUTE	Prints a hex dump of the received data as a QR code. When the power of the printer is turned off, the printer returns to the regular print mode. Communication cannot be performed with the status monitor, etc. while printing in the dump format.	
PRINT ADJUST	POSITION ADJUST	X ADJUST	0.00 MM +0.25 MM ~ +2.00 MM -2.00 MM ~ -0.25 MM	Corrects the position of the entire print image in the direction perpendicular to the feed direction of the paper. Set in increments of 0.25 mm.
		Y ADJUST	0.00 MM +0.25 MM ~ +2.00 MM -2.00 MM ~ -0.25 MM	Corrects the position of the entire print image in the feed direction of the paper. Set in increments of 0.25 mm.
	PAPER COLOR SET		0, +1, +2, -2, -1	Performs fine adjustment when faint white dots or other visual problems occur in the print results. Lower the setting when there are faint white dots occur and raise the setting when high density areas become lighter.
	SMR SETTING	YELLOW	0, +1, +2, +3, -3, -2, -1	Corrects uneven printing due to differences in the print density/print frequency or temperature/humidity. Change the yellow setting when the image is uneven.
		MAGENTA	0, +1, +2, +3, -3, -2, -1	Corrects uneven printing due to differences in the print density/print frequency or temperature/humidity. Change the magenta setting when the image is uneven.
		CYAN	0, +1, +2, +3, -3, -2, -1	Corrects uneven printing due to differences in the print density/print frequency or temperature/humidity. Change the cyan setting when the image is uneven.

Item	Setting	Description
BG SETTING	0, +1, +2, +3, -3, -2, -1	Corrects uneven printing due to differences in the print density/print frequency or temperature/humidity. Change this value when the background is dense.
DRUM CLEANING	ON OFF	Set ON to reduce white horizontal streaks that appear in the print results. The lifetime of the image drum unit is shorter when this is set to ON.
HIGH HUM. MODE	OFF ON	Set ON when the printed paper curls greatly.
NARROW PAPER SPEED	NORMAL MODE1	Sets the print speed of narrow paper. NORMAL: The print speed is not switched when printing on narrow paper. *If temperature adjustment occurs, the machine operates at low speed until printing stops. MODE1: The print speed is switched to low speed when printing on narrow paper.

ADMIN SETUP

The settings for the administrator of the machine. A password is required to enter this menu.

Item	Setting	Description	
Password	*****	Enter the password for the administrator menu. The default password is "999999."	
NETWORK SETUP	ENABLING DEFAULT GATEWAY	WIRED; WIRELESS (INFRASTRUCTURE)	Sets whether to use the default gateway of the wired LAN or wired LAN interface. This item is only displayed when [WIRELESS MODULE] is set to [ENABLE].
	WIRED	ENABLE; DISABLE	Sets whether to enable or disable wired LAN.
	TCP/IP	ENABLE; DISABLE	Sets whether to enable or disable the TCP/IP protocol.
	NETBIOS OVER TCP	ENABLE; DISABLE	Sets whether to enable or disable the NETBEUI protocol.
	IP ADDRESS SET	AUTO MANUAL	Sets the method for setting the IP address.
	IPV4 ADDRESS	xxx.xxx.xxx.xxx With a cable attached 169.254.XXX.XXX Without a cable attached 192.168.100.100	Sets the IP address.
	SUBNET MASK	xxx.xxx.xxx.xxx	Sets the subnet mask.
	GATEWAY ADDRESS	xxx.xxx.xxx.xxx	Sets the gateway address (default gateway). 0.0.0.0 means that there is no router.
	DHCPV6	ENABLE; DISABLE	Sets whether to enable or disable DHCPv6.
	WEB	ENABLE; DISABLE	Sets whether to enable or disable WEB.
	TELNET	ENABLE; DISABLE	Sets whether to enable or disable TELNET.
	FTP	ENABLE; DISABLE	Sets whether to enable or disable FTP.
	IPSEC	DISABLE	Disables IPsec.

Item	Setting	Description
	SNMP	ENABLE; DISABLE Sets whether to enable or disable SNMP.
	NETWORK SCALE	NORMAL SMALL NORMAL: Operates efficiently even when connected to a hub with the spanning tree function. However, the printer startup time may become longer when connected to a small LAN with two or three computers. SMALL: Supports a small LAN with two or three computers up to a large LAN. May not operate efficiently when connected to a hub with the spanning tree function.
	HUB LINK SETTING	AUTO NEGOTIATE 100BASE-TX FULL 100BASE-TX HALF 10BASE-T FULL 10BASE-T HALF Sets the method for connecting to hubs. AUTO: Automatically selects a connection method and tries connecting to all hubs. Other items: Only tries connecting to hubs using the set connection method.
	FACTORY DEFAULTS	EXECUTE Restores the default network settings.
	USB SETUP	USB SPEED SOFT RESET SERIAL NUMBER CONNECTED HOST
PRINT SETUP	COPIES	1 ~ 999 Sets the number of copies. The number of copies setting is disabled when printing information related to the machine.
	MEDIA CHECK	ENABLE; DISABLE Sets whether to check whether the paper size of the print data matches the paper size set in the machine. ENABLE: Detects a paper size error when the paper length is 17.5 mm or more shorter than the actual paper. DISABLE: Does not detect a paper size error.
	EDGE TO EDGE	ON, OFF Sets whether to expand the print area. ON: Sets the margin (unprintable area) to approximately 2 mm. OFF: Sets the margin to approximately 4.2 mm.
	RESOLUTION	600 DPI; 1200 DPI Sets the resolution for printing.
	TONER SAVE	OFF; LOW; MIDDLE; HIGH Sets the amount of toner to save. When set to OFF, toner is not saved.
	ORIENTATION	PORTRAIT; LANDSCAPE Sets the print orientation.
	EDIT SIZE	FEEDER SIZE CUSTOM Sets the area to print when the paper size is not specified in the print data FEEDER SIZE: Uses the value set in [MENU] > [FEEDER CONFIG] > [X DIMENSION] / [Y DIMENSION]. CUSTOM: Uses the value set in the following [X DIMENSION] / [Y DIMENSION].
	X DIMENSION	1.00 IN / 25.0 MM ~ 2.91 IN / 74.0 MM ~ 3.40 IN / 86.0 MM Sets the default paper width for custom paper. The paper width is the length perpendicular to the paper feed direction.
	Y DIMENSION	2.10 IN / 53.0 MM ~ 8.27 IN / 210.0 MM ~ 21.70 IN / 551.0 MM Sets the default paper length for custom paper. The paper length is the length in the same direction as the paper feed direction.
	BARCODE ADJUST	OFF ON1 ON2 Adjusts the line width of barcodes ON1: Makes barcodes one dot thinner than the standard line width. ON2: Makes barcodes two dots thinner than the standard line width.

Item	Setting	Description	
PRESENTER MODE	OFF MODE1 MODE2	Configures paper output. OFF: Outputs paper with the regular output method. MODE1: Retains the paper with the Presenter Unit and prints the next page when the paper is pulled out. MODE2: Retains the paper with the Presenter Unit and prints the next page when print data exists. *Displayed when [PRESENTER UNIT] is set to [ENABLE].	
COLOR MENU	CMY100% DENSITY ENABLE DISABLE	Selects whether to use halftones when outputting in 100% C, M, or Y.	
PCL SETUP	FONT SOURCE	RESIDENT DOWNLOADED	Sets the location of the PCL fonts. DOWNLOADED is displayed when software fonts have been downloaded to RAM permanently.
	FONT NO.	I0 ~ I30	Sets the PCL font number.
	FONT PITCH	0.44 CPI ~ 10.00 CPI ~ 99.99 CPI	Sets the width of the PCL default font. Set in characters per inch (fixed pitch scalable font by default).
	FONT HEIGHT	4.00 POINT ~ 12.00 POINT ~ 999.75 POINT	Sets the height of the PCL default font. The value is displayed in increments of 0.25 point.
	SYMBOL SET	PC-8; PC-8 Dan/Nor PC-8 Grk; PC-8 TK PC-775; PC-850 PC-851 Grk; PC-852 PC-855; PC-857 TK PC-858; PC-862 Heb PC-864 L/A; PC-866 PC-866 Ukr; PC-869 PC-1004; Pi Font Plska Mazvia; PS Math; PS Text Roman-8; Roman-9 Roman Ext; Serbo Croat1; Serbo Croat2 Spanish; UCS-2 Ukrainian; VN Int'l VN Math; VN US Win 3.0; Win 3.1 Arb Win 3.1 L/G; Win 3.1 BlT; Win 3.1 Cyr; Win 3.1 Grk; Win 3.1 Heb; Win 3.1 L1 Win 3.1 L Win 3.1 L5	Sets the PCL symbol set.

Item	Setting	Description
	Wingdings, Dingbats MS, Symbol, OCR-A, OCR-B, OCRB Subset2, HP ZIP, USPSFIM, USPSSTP, USPSZIP, Arabic-8, Bulgarian, CWI Hung, DeskTop, German, Greek-437, Greek-437 Cy, Greek-737, Greek-8, Greek-928, Hebrew NC, Hebrew OC, Hebrew-7, Hebrew-8, IBM-437, IBM-850, IBM-860, IBM-86, IBM-865, ISO Dutch, ISO L1, ISO L, ISO L4, ISO L5, ISO L6, ISO L9, ISO Swedish1, ISO Swedish2, ISO Swedish3, ISO-2 IRV, ISO-4 UK, ISO-6 ASC, ISO-10 S/F, ISO-11 Swe, ISO-14 JASC, ISO-15 Ita, ISO-16 Por, ISO-17 Spa, ISO-21 Ger, ISO-25 Fre, ISO-57 Chi, ISO-60 No, ISO-61 Nor, ISO-69 Fre, ISO-84 Por, ISO-85 Spa, ISO-Cyr, ISO-Grk, ISO-Hebrew, Kamenicky, Legal, Math-8, MC Text, MS Publish, PC Ext D/N, PC Ext US, PC Set1, PC Set2 D/N, PC Set2 US	

Item	Setting	Description
	WHITE PAGE SKIP	ON, OFF Selects whether to print blank pages ON: Do not print blank pages OFF: Print blank pages
	CR FUNCTION	CR CR+LF Sets the operation to take when a CR code is received. CR: Return, CR+LF: Return and line feed
	LF FUNCTION	LF LF+CR Sets the operation to take when an LF code is received. LF: Line feed, LF+CR: Line feed and return
	PRINT MARGIN	NORMAL, 1/5 INCH 1/6 INCH 1/12.5 INCH Sets the unprintable area of the paper.
	PEN WIDTH ADJUST	ON, OFF Sets whether to enhance thin lines so they look thicker.
PANEL SETUP	NEARLIFE STATUS	ENABLE DISABLE Sets whether to display a message when a near life warning has occurred ENABLE: Display a near life warning. DISABLE: Do not display a near life warning.
	NEARLIFE LED	ENABLE DISABLE Sets whether to light up the LED when a near life warning has occurred. ENABLE: Light up the LED. *For the image drum unit, lights up when [PANEL SETUP] > [NEARLIFE STATUS] is set to [ENABLE] DISABLE: Do not light up the LED.
BUZZER SETUP	ERROR VOLUME	OFF, LOW, HIGH Sets the buzzer volume when an error has occurred in the machine.
	PRINT COMPLETION VOLUME	OFF, LOW, HIGH Sets the buzzer volume when printing is completed.
	PRINT COMPLETION BUZZER	PAGE END, JOB END Sets the timing for sounding the buzzer when printing is completed Displayed when [PRINT COMPLETION VOLUME] is set to [LOW] or [HIGH]. PAGE END: The buzzer sounds each time printing of one page is complete. JOB END: The buzzer sounds when printing of all pages of the print data is complete.
POWER SETUP	AUTO PW OFF	ENABLE AUTO CONFIG DISABLE Set the Auto Power Off operation. ENABLE: The machine enters the Auto Power Off mode even when connected via a LAN cable. AUTO CONFIG: The machine does not enter the Auto Power Off mode when connected via a LAN cable. The machine also does not enter the Auto Power Off mode when the wireless LAN of a USB host is connected and wireless LAN is enabled. The machine enters the OFF mode when connected via USB. DISABLE: The power does not automatically turn off.
FEEDER SETUP	UNIT OF MEASURE	INCH MILLIMETER Specifies the unit for custom paper sizes.

Item			Setting	Description	
OTHERS SETUP	RAM SETUP	RECEIVE BUF SIZE	AUTO, 0.5 MB 1 MB, 2 MB 4 MB, 8 MB 16 MB, 32 MB	Sets the reception buffer size to secure for the local interface. Normally, [AUTO] is used. When memory overflow errors occur, lowering this setting may improve the problem. The setting can also be raised to shorten the release time on the computer side.	
	FLASH SETUP	FLASH INITIALIZE	EXECUTE	Initializes the flash memory. The downloaded demo data, etc. displayed in the file list is deleted.	
	STORAGE SETUP	ENABLE INITIAL	NO YES	Prevents setting changes resulting from initialization of the flash memory.	
	LAN- GUAGE SETUP	LAN- GUAGE SELECT	CATALAN CZECH, DANISH DUTCH, ENGLISH FINNISH, FRENCH GERMAN, HUNGARI- AN, ITALIAN JAPANESE, NORWE- GIAN POLISH, PORTU- GUESE PORTUGUESE (BRAZIL), SPANISH SWEDISH, TURKISH	Selects the language displayed on the LCD. However, machine information such as reports is printed in English.	
			LAN- GUAGE INITIALIZE	EXECUTE	Initializes the downloaded user language message file.
	JOB CANCEL SETUP	CANCEL KEY BE- HAVIOR	SHORT LONG OFF	Sets the operation performed when the job cancel button is pressed. SHORT: Execute job cancellation with a short press (2 seconds or less). LONG: Execute job cancellation with a long press (2 to 5 seconds). OFF: Ignore presses of the job cancel button. In other words, disable job cancellation by pressing the job cancel button.	
			INQUIRY DISPLAY	ON OFF	Sets whether to display the query screen when job cancellation is executed. ON: Display the query screen. OFF: Execute job cancellation without displaying the query screen.
			FOCUS POSITION	YES NO	Sets whether to place the focus on [YES] or [NO] on the query screen for job cancellation YES: Place the focus on [YES]. NO: Place the focus on [NO].
			DISPLAY TIMEOUT	60 to 180 to 300	Sets the timeout value for the query screen when job cancellation is executed. When a timeout occurs, printing is executed with the cancellation operation disabled.

Item		Setting	Description
NEARLIFE SETUP	DRUM NEARLIFE	500, 1000, 1500 2000, 2500, 3000 3500, 4000, 4500 5000	Sets the timing for displaying the near life warning for the image drum unit. Displays the near life warning for the image drum unit in front of the selected value for the image drum unit lifetime.
	FUSER NEARLIFE	500, 1000, 1500 200, 2500, 3000 3500, 4000, 4500 5000	Sets the timing for displaying the near life warning for the fuser unit. Displays the near life warning for the fuser unit in front of the selected value for the fuser unit lifetime.
	BELT NEARLIFE	500, 1000, 1500 2000, 2500, 3000 3500, 400, 4500 5000	Sets the timing for displaying the near life warning for the transfer belt unit. Displays the near life warning for the transfer belt unit in front of the selected value for the transfer belt unit lifetime.
ERASE PRIVACY DATA		EXECUTE	The following data set in the machine is erased. • Administrator password, values set for menus • Data registered in the machine
PRESENTER UNIT		DISABLE ENABLE	Sets whether to enable or disable the Presenter Unit. ENABLE: Attached DISABLE: Not attached Match this setting with the status of the Presenter Unit. Paper jams will occur if the setting does not match.
SETTINGS	MENU RESET	EXECUTE	Resets the default menu settings of the machine.
	SAVE MENU	EXECUTE	Saves the current menu settings. The menu is overwritten with that saved at the time of last execution.
	RESTORE MENU	EXECUTE	Changes the menu to the sved menu settings. Displayed when [SAVE MENU] has been executed to save the menu settings. Disabled when executed when the machine has print data.
CHANGE PASSWORD	NEW PASSWORD	*****	Sets the new password for entering [ADMIN SETUP] and [BOOT MENU]. The password is set using 6 to 12 numbers or lower case letters.
	VERIFY PASSWORD	*****	Enter the new password set in [NEW PASSWORD] again for confirmation purposes. The password is set using 6 to 12 numbers or lower case letters.

PRINT STATISTICS

Settings related to print statistics.

Item	Setting	Description
USAGE REPORT	ENABLE	Sets whether to enable or disable the print statistics function.
	DISABLE	The device restarts if this setting is changed.
RST MAIN CNT	EXECUTE	Resets the main counter.
CHANGE PASSWORD	NEW PASSWORD	**** Sets the new password for entering [PRINT STATISTICS]. The password is set using a 4 digit number.
	VERIFY PASSWORD	**** Enter the new password set in [NEW PASSWORD] again for confirmation purposes.

CALIBRATION

Settings related to color.

Item	Setting	Description
DENSITY CONTROL	FULL QUICK MANUAL	Sets whether to automatically perform density correction. FULL: Automatically perform density correction. QUICK: Automatically perform density correct when the printer deems it necessary. MANUAL: Do not automatically perform density correction.
ADJUST DENSITY	EXECUTE	Executes density correction. Execute it when the printer is in standby.
COLOR TUNING	PRINT PATTERN	Prints a color tuning pattern.
CYAN TUNING	CYAN HIGHLIGHT	0, +1, +2, +3, -3, -2, -1 Adjusts the cyan highlights (light areas). Positive values are darker and negative values are lighter.
	CYAN MID-TONE	0, +1, +2, +3, -3, -2, -1 Adjusts the cyan intermediate areas. Positive values are darker and negative values are lighter.
	CYAN DARK	0, +1, +2, +3, -3, -2, -1 Adjusts the cyan dark areas. Positive values are darker and negative values are lighter.
MAGENTA TUNING	MAGENTA HIGHLIGHT	0, +1, +2, +3, -3, -2, -1 Adjusts the magenta highlights (light areas). Positive values are darker and negative values are lighter.
	MAGENTA MID-TONE	0, +1, +2, +3, -3, -2, -1 Adjusts the magenta intermediate areas. Positive values are darker and negative values are lighter.
	MAGENTA DARK	0, +1, +2, +3, -3, -2, -1 Adjusts the magenta dark areas. Positive values are darker and negative values are lighter.
YELLOW TUNING	YELLOW HIGHLIGHT	0, +1, +2, +3, -3, -2, -1 Adjusts the yellow highlights (light areas). Positive values are darker and negative values are lighter.
	YELLOW MID-TONE	0, +1, +2, +3, -3, -2, -1 Adjusts the yellow intermediate areas. Positive values are darker and negative values are lighter.
	YELLOW DARK	0, +1, +2, +3, -3, -2, -1 Adjusts the yellow dark areas. Positive values are darker and negative values are lighter.
COLOR DENSITY	CYAN DENSITY	0, +1, +2, +3, -3, -2, -1 Adjusts the cyan density. Positive values are darker and negative values are lighter. This setting is enabled when printing after density correction is executed.
	MAGENTA DENSITY	0, +1, +2, +3, -3, -2, -1 Adjusts the magenta density. Positive values are darker and negative values are lighter. This setting is enabled when printing after density correction is executed.
	YELLOW DENSITY	0, +1, +2, +3, -3, -2, -1 Adjusts the yellow density. Positive values are darker and negative values are lighter. This setting is enabled when printing after density correction is executed.
ADJUST REGISTRATION	EXECUTE	When this menu is selected, the printer executes automatic color shift correction. Execute this when the machine is idle.

WIRELESS SETTING

Settings related to wireless LAN.

Item		Setting	Description	
WIRELESS (INFRASTRUCTURE)		ENABLE DISABLE	Sets whether wireless (infrastructure) is enabled or disabled.	
NETWORK SETTING	IP ADDRESS SET	AUTO MANUAL	Sets the method for setting the IP address.	
	IPV4 ADDRESS	xxx.xxx.xxx.xxx	Sets the IP address.	
	SUBNET MASK	xxx.xxx.xxx.xxx	Sets the subnet mask.	
	GATEWAY ADDRESS	xxx.xxx.xxx.xxx	Sets the gateway address (default gateway).	
	DHCPV6	ENABLE DISABLE	Sets DHCPv6.	
WPS SETUP	WPS-PBC		Executes WPS-PBC.	
	WPS-PIN		Executes WPS-PIN.	
WIRELESS SELECTION	xxxxxx		Lists the wireless APs that have been detected.	
	MANUAL SETUP	SSID	Enter an SSID.	
		SECURITY	DISABLE WEP WPA/WPA2-PSK WPA2-PSK WPA/WPA2-EAP *1 WPA2-EAP *2	Sets the security for the wireless LAN function.
		*1: Can only be set for the Web		
		*2: Can only be set for the Web		
		WEP KEY		Enter the WEP Key.
		WPA ENCRYPTION TYPE	AES TKIP/AES	Displays the WPA-PSK encryption method. A unique value is determined by the security settings. (It cannot be switched with this menu.)
		WPA PRE-SHARED KEY		Enter the pre-shared Key.
	EXECUTE		Executes the changes to the security settings.	
RECONNECTION		EXECUTE	Wireless LAN reconnection will be executed.	

WIRELESS (AP MODE) SETTING

Settings related to wireless LAN.

Item	Setting	Description
WIRELESS(AP MODE)	ENABLE DISABLE	Sets whether wireless (AP mode) is enabled or disabled.
AUTOMATIC SETUP (PUSHBUTTON)		When YES is selected, automatic connection via a push button is started. If the connection fails, the machine returns to the previous screen. If it succeeds, SUCCEEDED PRESS OK is displayed.
MANUAL SETUP	SSID	Displays the SSID.
	PASSWORD	Displays the password.
CONNECTION SETTING	SSID	Enter an SSID.
	PASSWORD	Enter the password.
	IPV4 ADDRESS	xxx.xxx.xxx.xxx Enter the IP address.
	EXECUTE	Starts connecting.
AP MODE USER SETTING	ENABLE DISABLE	Sets whether to disclose the AP mode information to people other than the administrator.

BOOT MENU

Perform the following operation to display the BOOT MENU.

1. If the machine is on, turn it off.
2. Turn the machine on while holding «OK» button on the operation panel. Hold «OK» button until [BOOT MENU] is displayed on the screen.
3. When [BOOT MENU] is displayed, release your finger and press «OK» button again.
4. When the screen for entering the password is displayed, enter the password. The password is the same as that used to enter the [ADMIN SETUP] menu for the administrator.

Item	Setting	Description
WIRELESS MODULE	ENABLE DISABLE	Enables the wireless LAN board. When set to ENABLE, the setting is retained even when the wireless LAN board is removed.
MENU LOCKOUT	ON OFF	Sets the menu lockout function. ON: The menu is not displayed. OFF: The menu is displayed.
PANEL LOCKOUT	MODE1 MODE2 OFF	Sets the panel lockout function. MODE1: The «ONLINE», «OK», «CANCEL», «POWER SAVE», and «FEED/CUT» buttons can be used, but other buttons are disabled. MODE2: The «ONLINE», «OK», «POWER SAVE», and «FEED/CUT» buttons can be used, but other buttons are disabled. OFF: All buttons are disabled.

Item		Setting	Description
MENU OPERATION SETUP	UP/DOWN KEY	NORMAL TYPE OLD TYPE	<p>Sets the operation performed when «^» button or «v» button is pressed when selecting a category/item/value in a menu.</p> <p>NORMAL TYPE: When «^» button is pressed, the machine returns to the previous item (up in the displayed list). When «v» button is pressed, the machine moves to the next item (down in the displayed list).</p> <p>OLD TYPE: When «^» button is pressed, the machine moves to the next item (down in the displayed list). When «v» button is pressed, the machine returns to the previous item (up in the displayed list).</p> <p>A confirmation message is displayed when this setting is changed.</p> <p>When [YES] is selected, the setting is changed and the machine restarts.</p>
POWER RETURN		ALWAYS ON ALWAYS OFF LAST STATE	<p>Sets the power supply method when the machine recovers from a power failure.</p> <p>ALWAYS ON: The machine restarts when the power supply resumes.</p> <p>ALWAYS OFF: The power needs to be turned on manually.</p> <p>LAST STATE: The state before the power failure is resumed.</p>
SENSOR RESET		EXECUTE	<p>Resets the calibration values of the paper sensors.</p> <p>The paper sensor calibration values calibrated by executing [MENUS] > [SENSOR CONFIG] > [SENSOR CALIBRATION] are reset.</p> <p>*Execute this menu operation if the "OPEN TOP COVER/380:PAPER JAM" error occurs after executing [SENSOR CALIBRATION] and the error is not cleared when the machine is restarted. If paper sensor adjustment is required after executing this menu operation, execute [SENSOR CALIBRATION] again.</p>

Loading Paper

Available Paper Sizes

Paper Format

Paper Format	Description
Continuous Paper	Paper wound into a roll or paper folder along a perforation
Cut Sheet	Paper cut into rectangles in the range of 25 mm to 86 mm width and 53 mm to 551 mm length

Paper Type

Paper Type	Description
Plain Paper	Wood-free paper

Types of Marks Used for Cutting Paper

 Paper without a mark is cut at the specified length.

Mark Type	Description
Black Mark	Mark position: Paper front or back
Hole	
GAP	Pre DieCut label stock

Paper Specifications

Continuous Paper: Without Mark

Paper Thickness		0.080 to 0.250 mm
Paper Width	A	25 to 86 mm
Cut Length	F	53 to 551 mm
Side margin	a	4.2 mm
	b	2 mm
Top margin	c	4.2 mm
	d	2 mm
Bottom margin	e	6.3 mm
	f	2 mm
Paper Format Setting		CONTINUOUS PAPER
Cut Type Setting		LENGTH
Usage Conditions		
Guaranteed Print Range		
Printable Range	B	Maximum 80 mm

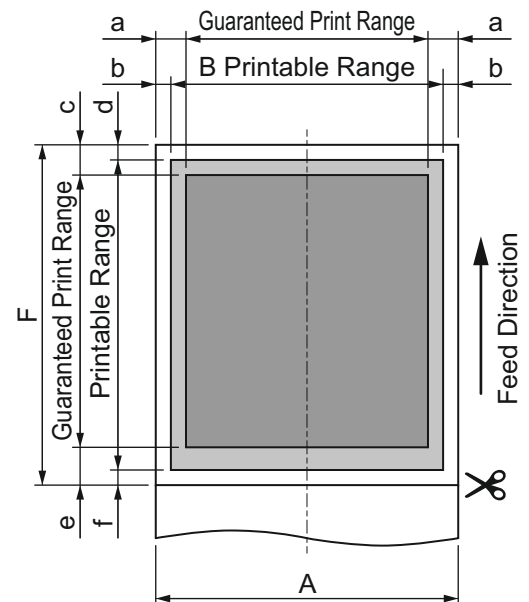

Continuous Paper: With Black Mark

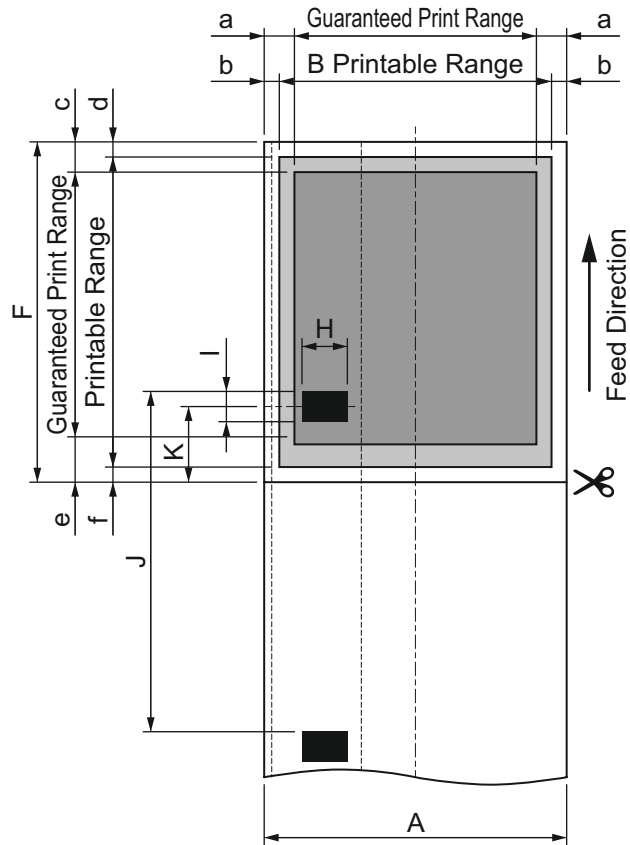

Paper Thickness		0.080 to 0.250 mm
Paper Width	A	25 to 86 mm
Cut Length	F	53 to 551 mm
Side margin	a	4.2 mm
	b	2 mm
Top margin	c	4.2 mm
	d	2 mm
Bottom margin	e	6.3 mm
	f	2 mm
Black Mark Width	H	9 mm or more
Black Mark Length	I	2.5 to 13 mm
Black Marks Pitch	J	53 to 551 mm
Cut Position	K	-6.5 to length of Black Marks Pitch (J)
Unprintable Range for Pre-printing		In order to prevent misdetection of the black mark, do not print around the mark.
Paper Format Setting		CONTINUOUS PAPER
Cut Type Setting		When the black mark is on the front: B/M(FRONT)
		When the black mark is on the back: B/M(BACK)
Usage Conditions		Use black marks printed in carbon.
Guaranteed Print Range		
Printable Range	B	Maximum 80 mm

Continuous Paper: With Holes + GAP

With holes in the paper center

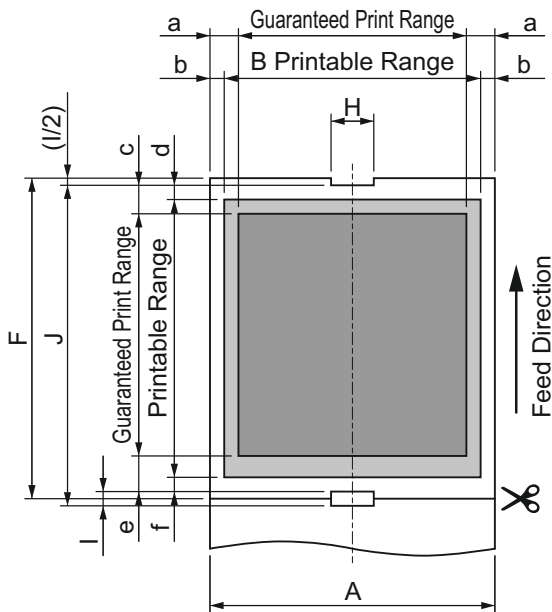

Without holes in the paper center

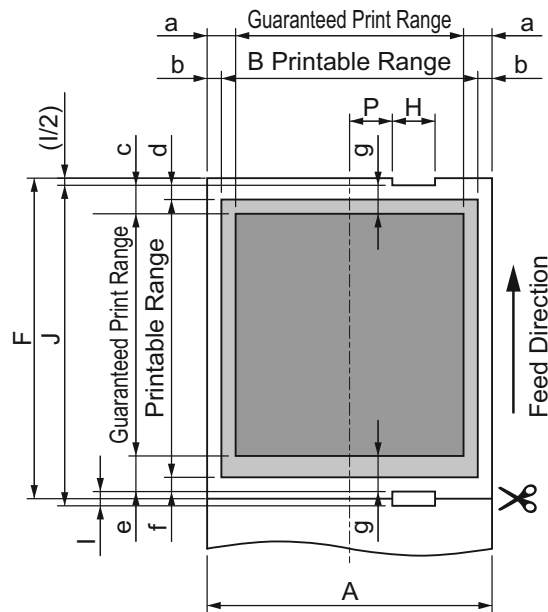

Paper Thickness		0.080 to 0.250 mm
Paper Width	A	36 to 86 mm
Cut Length	F	53 to 551 mm
Side margin	a	4.2 mm
	b	2 mm
Top margin	c	4.2 mm
	d	2 mm
Bottom margin	e	6.3 mm
	f	2 mm
Hole margin	g	2 mm or more
Hole Width	H	7 mm or more
Hole Length	l	With holes in the paper center: 1.6 to 5 mm< Without holes in the paper center: 1.6 to 13 mm
Hole Pitch	J	53 to 551 mm
Paper Center Separation Distance Right Side	P(R)	3.5 to 36 mm
Paper Center Separation Distance Left Side	P(L)	3.5 to 29 mm
Paper Format Setting		CONTINUOUS PAPER
Cut Type Setting		With holes in the paper center: CENTER HOLE Without holes in the paper center: SIDE HOLE
Usage Conditions		When there is a hole in the center of the paper, set [Bottom margin] to a value equal or above the size of the hole. When there is not a hole in the center of the paper, set [Top margin] and [Bottom margin] to a value equal or above half the size of the hole.
Guaranteed Print Range		
Printable Range	B	Maximum 80 mm

Cut Sheet

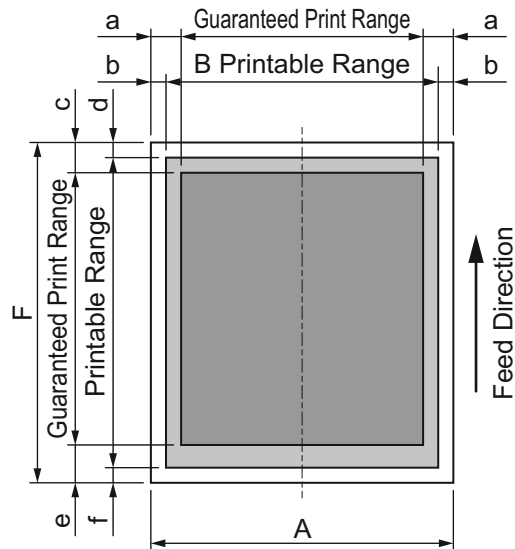

Paper Thickness		0.060 to 0.250 mm
Paper Width	A	25 to 86 mm
Cut Length	F	53 to 551 mm
Side margin	a	4.2 mm
	b	2 mm
Top margin	c	4.2 mm
	d	2 mm
Bottom margin	e	6.3 mm
	f	2 mm
Paper Format Setting		CUT PAPER
Cut Type Setting		
Usage Conditions		
Guaranteed Print Range		
Printable Range	B	Maximum 80 mm

Roll Paper

Outer Wind Diameter	203.2 mm or less
Wind Core Inner Diameter	50.8 mm
Wind Core Outer Diameter	Not specified
Printed Surface	Outer surface only

Paper with Perforation

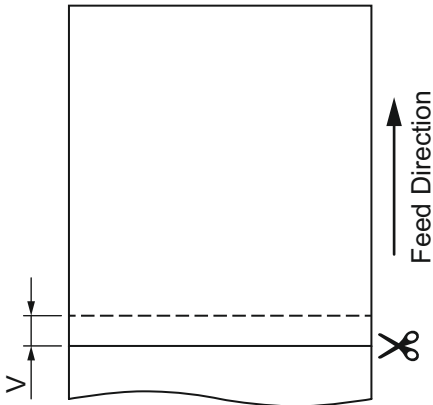

Paper Thickness		0.060 to 0.250 mm
Cut position	V	1.5 mm or more

 When cutting paper with perforation, cut the paper at a position at least 1.5 mm away from the perforation.

Paper Storage

Store paper under the following conditions to maintain quality.

- In a dark, dry, and flat location such as inside a cabinet.
- On a flat surface
- Temperature: 20°C
- Humidity: 50% RH (relative humidity)

Do not store paper in places such as the following:

- Directly on the floor
- In a location exposed to direct sunlight
- Near the inside of an exterior wall
- On an uneven surface
- Where static electricity may be generated
- Where temperature may become excessively high or change rapidly
- Near a photocopier, air conditioner, heater, or duct
- Do not open the package of the paper until ready to use the paper.
- Do not leave paper unwrapped for a long period. Doing so may result in printing problems.
- Reduced print quality or paper curling may occur due to the paper type, usage conditions, or storage conditions.

Flow of Loading Paper

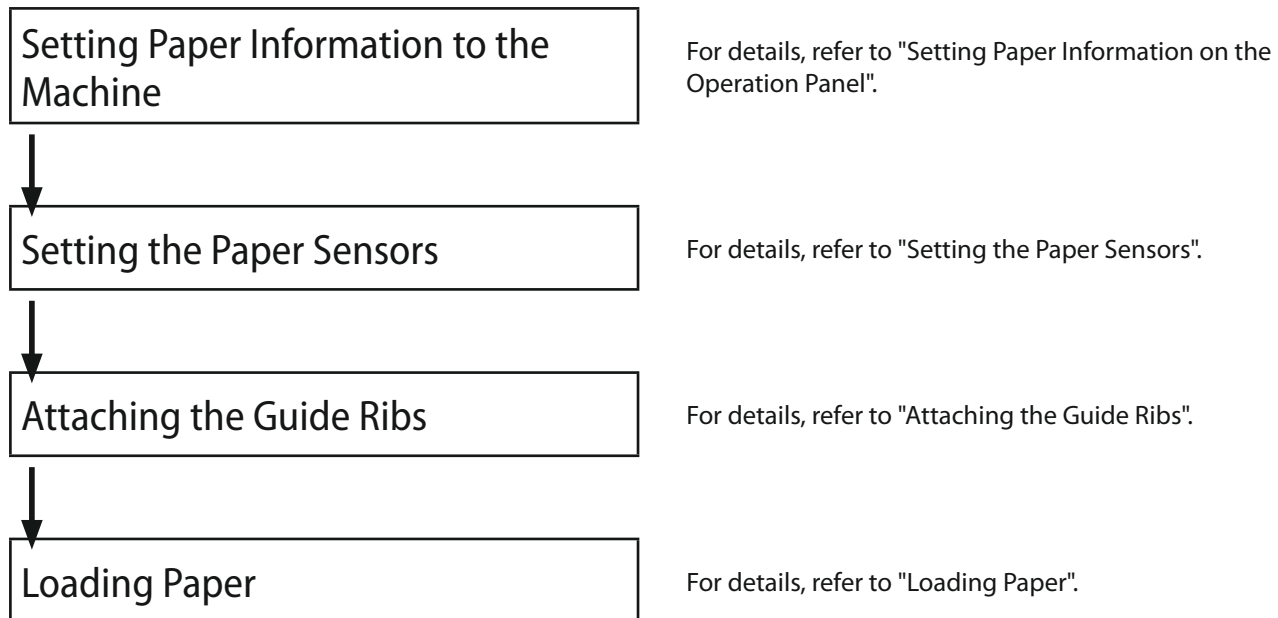

When loading of the paper is complete, start printing.

Setting Paper Information on the Operation Panel

Use the operation panel to set the information for the paper to use to the machine.

Set the information in the following order: paper format → paper size → paper weight → cut type → cut position

Paper Format

For roll paper or continuous paper folded along a perforation (z-fold), set [CONTINUOUS PAPER].

For paper cut into single sheets, set [CUT PAPER].

- Confirm that [READY TO PRINT] is displayed on the machine.
- Press \wedge button or \vee button several times to display [MENUS], and press «OK» button.
- Press \wedge button or \vee button to display [FEEDER CONFIG], and press «OK» button.
- Press \wedge button or \vee button to display [PAPER FORM], and press «OK» button.
- With the setting flashing, press \wedge button or \vee button to display the value you want to set, and press «OK» button.
- Confirm that the setting stops flashing and "*" is displayed to the right of the value you want to set.

Paper Size

You can set 25.0 mm to 86.0 mm (1.00 inches to 3.40 inches) for the width and 3.0 mm to 551 mm (2.10 inches to 21.70 inches) for the length.

- Press \vee button once to display [X DIMENSION], and press «OK» button.
- With the setting flashing, press \wedge button or \vee button to display the value you want to set, and press «OK» button.
- Confirm that the setting stops flashing and "*" is displayed to the right of the value you want to set.
- Press \vee button once to display [Y DIMENSION], and press «OK» button.
- With the setting flashing, press \wedge button or \vee button to display the value you want to set, and press «OK» button.
- Confirm that the setting stops flashing and "*" is displayed to the right of the value you want to set.

Paper Weight

Set the weight of the paper to use. You can set LIGHT, MEDIUM LIGHT, MEDIUM, MEDIUM HEAVY, HEAVY, ULTRA HEAVY1, ULTRA HEAVY2.

- Press \vee button once to display [MEDIWEIGHT], and press «OK» button.
- With the setting flashing, press \wedge button or \vee button to display the value you want to set, and press «OK» button.
- Confirm that the setting stops flashing and "*" is displayed to the right of the value you want to set.

Cut Type

Set the type of mark used for cutting the paper. Set it according to the paper to use.

When the paper has a black mark on the surface that is printed on: B/M(FRONT)

When the paper has a black mark on the surface that is not printed on: B/M(BACK)

For paper with a hole in the center: CENTER HOLE

For paper without a hole in the center: SIDE HOLE

For label stock with GAP set to: CENTER HOLE

For paper without a mark: LENGTH

- Press \vee button once to display [CUT TYPE], and press «OK» button.
- With the setting flashing, press \wedge button or \vee button to display the value you want to set, and press «OK» button.
- Confirm that the setting stops flashing and "*" is displayed to the right of the value you want to set.
- If you set [LENGTH], proceed to step 23.
If you set something other than [LENGTH], proceed to step 20.

Cut Position

This setting specifies the cut position of paper with a black mark or hole.

When set to 0 mm, the paper is cut at the center of the black mark or hole.

The values that can be set are indicated below.

Paper with a black mark: -6.5 mm (-0.25 inches) to the paper length

Paper with a hole: -6.5 mm to 6.5 mm (-0.25 inches to 0.25 inches)

 Generally set this to 0 mm when printing on paper with a hole. If the paper cannot be cut in the center of the hole, change the setting.

- Press \vee button twice to display [CUT POSITION SET], and press «OK» button.
- With the setting flashing, press \wedge button or \vee button to display the value you want to set, and press «OK» button.
- Confirm that "*" is displayed to the right of the value you want to set.
- Press «ONLINE» button, or press «BACK» button until "READY TO PRINT" is displayed.

Setting the Paper Sensors

Checking the Paper Sensor Position

The position for setting the paper sensors differs according to the paper to use. Adjust the paper sensors while checking the position based on the table below.

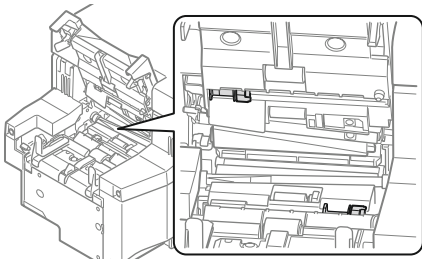

A paper jam will be incorrectly detected if the sensor position and cut type setting of the machine do not match. In this case, change the position of the top sensor and bottom sensor so that they do not overlap if their positions were matching or to match if their positions were overlapped.

Supported Paper Type	Sensor Position	Printer Driver or Operation Panel Setting*		
		PAPER FORM	CUT TYPE	GAP LENGTH
Paper with black mark on the front	Top: Position of black mark Bottom: Position that does not overlap with the black mark on the front 	CONTINUOUS PAPER	B/M(FRONT)	-

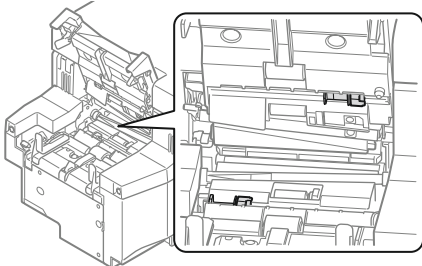
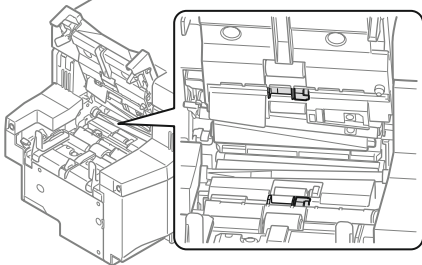
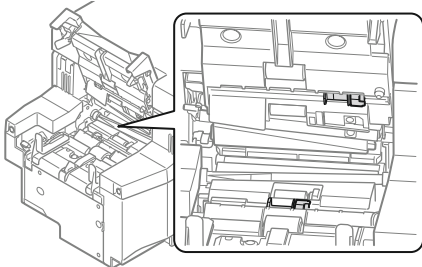
Supported Paper Type	Sensor Position	Printer Driver or Operation Panel Setting*	
		PAPER FORM	CUT TYPE
Paper with black mark on the back	<p>Top: Position that does not overlap with the black mark on the back</p> <p>Bottom: Position of black mark</p> 	CONTINUOUS PAPER	B/M(BACK)
Paper with holes + GAP	<p>Top: Position of hole</p> <p>Bottom: Position of hole</p> 	CONTINUOUS PAPER	SIDE HOLE CENTER HOLE GAP
Paper without mark	<p>Top: Position that does not overlap with the bottom sensor</p> <p>Bottom: Center</p> 	CONTINUOUS PAPER	LENGTH

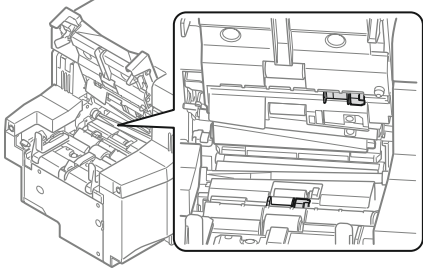
Supported Paper Type	Sensor Position	Printer Driver or Operation Panel Setting*	
		PAPER FORM	CUT TYPE
Cut Sheet	Top: Position that does not overlap with the bottom sensor Bottom: Center 	CUT PAPER	-

*The setting of the printer driver is prioritized.

Adjusting the Paper Sensor Position



If the guide ribs are attached, remove them before adjusting the position of the paper sensors. When the adjustment is complete, attach them again.

For information on attaching the guide ribs, refer to "Attaching the Guide Ribs."

Insert your finger below the gray lever on the left of the machine rear, and lift it up to open the feeder cover.

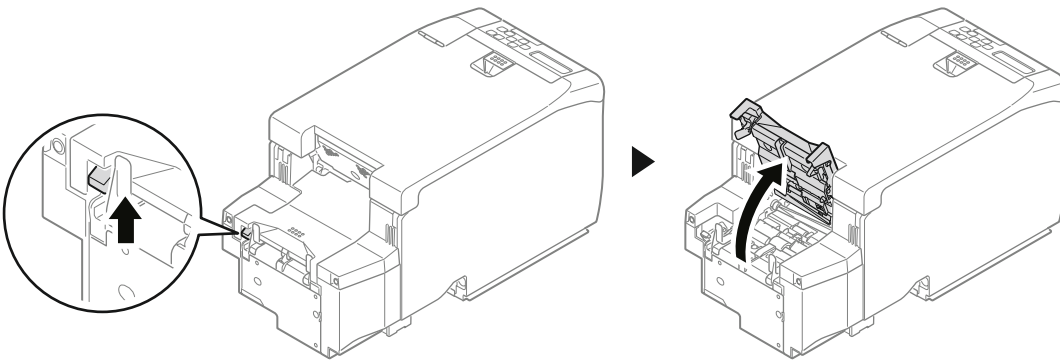

Insert a stick-shaped thing with a pointing tip (such as a small flat head screwdriver) into the back of the metal part of the upper sensor on the back of the feeder cover, and pull it out to unlock it.

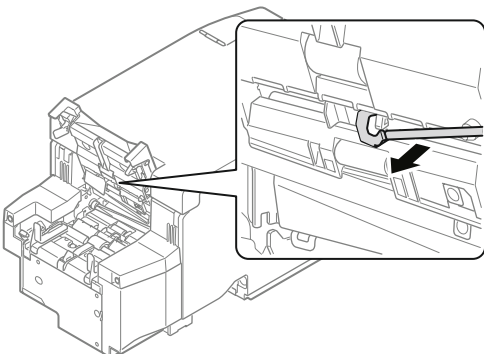

Hold the both ends of the upper sensor and move it to the correct position.

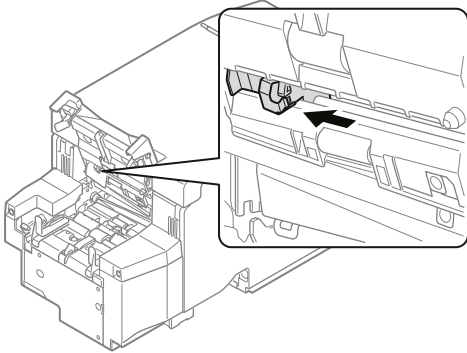

Push in the metal part of the upper sensor to fix the sensor.

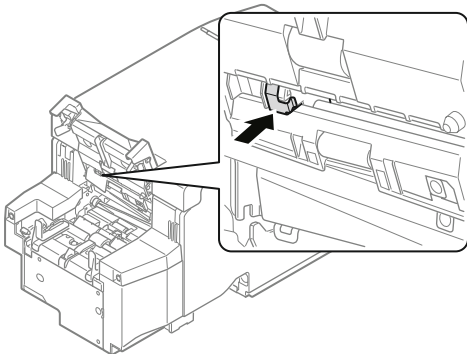

Insert a stick-shaped thing with a pointing tip (such as a ball-point pen) below the metal part of the lower sensor, and pull it out to unlock it.

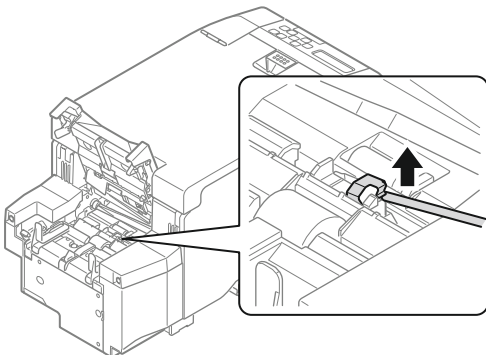

Hold the both ends of the lower sensor and move it to the correct position.

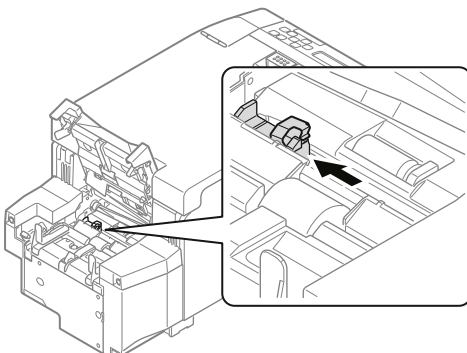

Push in the metal part of the lower sensor to fix the sensor.

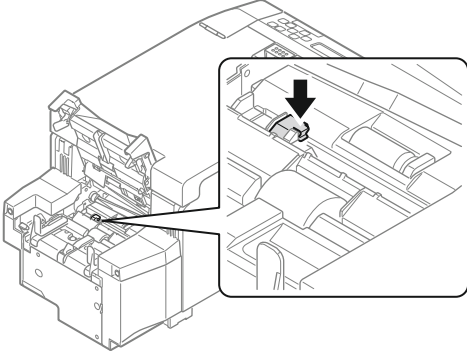

Close the feeder cover.

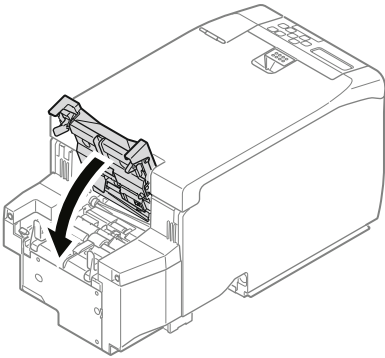

Attaching the Guide Ribs

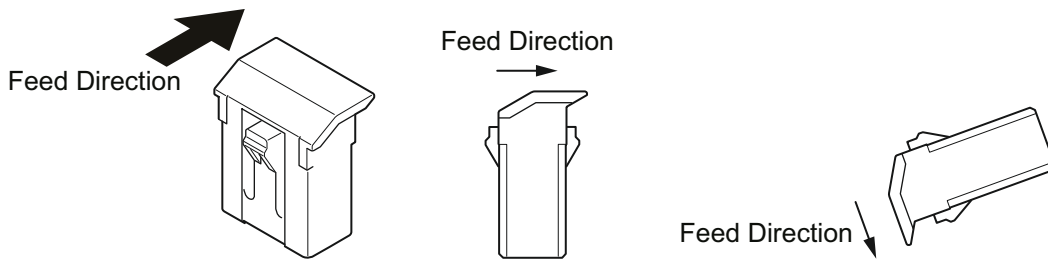

Turn the machine to make its rear side face to you.

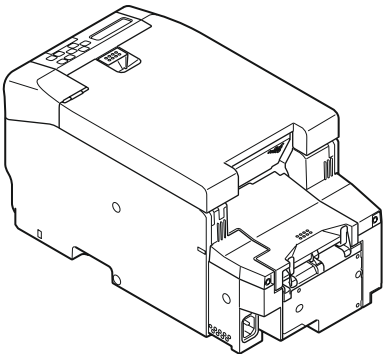

Insert your finger below the gray lever on the left of the machine rear, and lift it up to open the feeder cover.

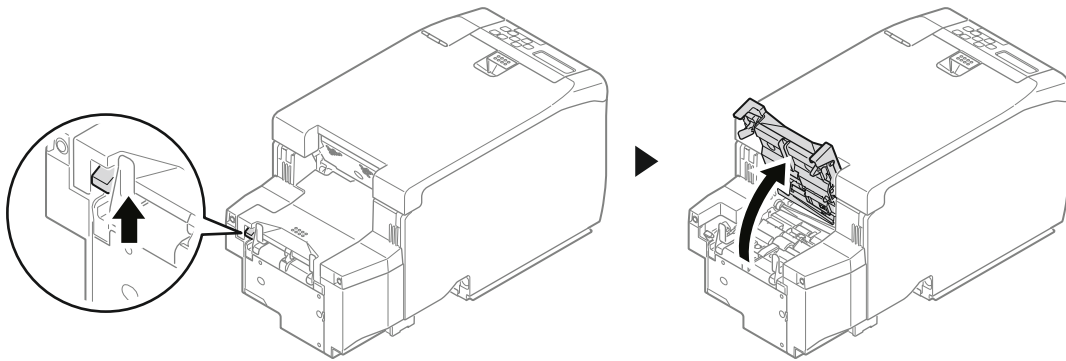

Attach the guide rib to the position where the paper edge will be retained of the groove where the paper sensors move.

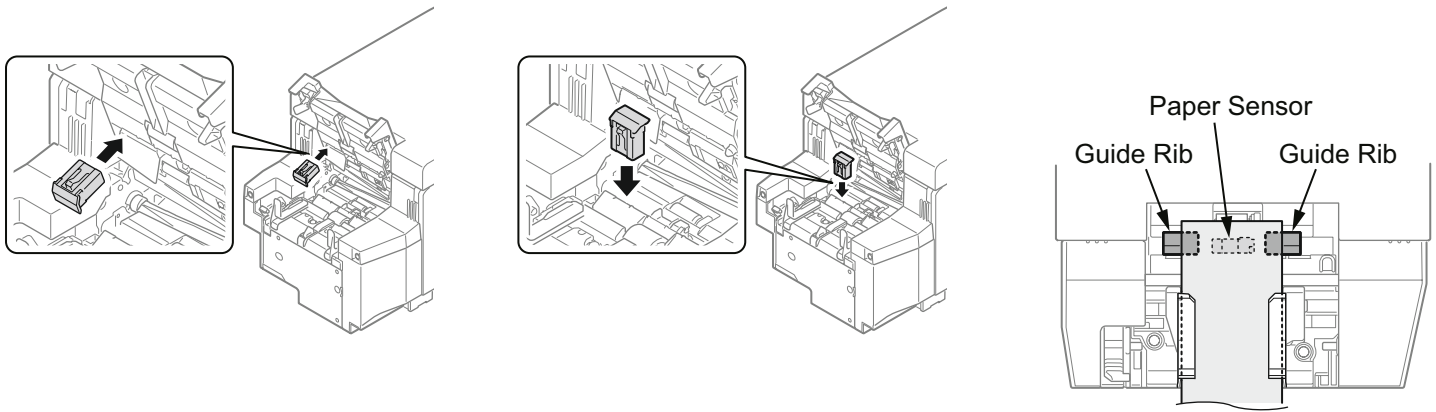

- Ensure that the paper sensors are not moved.
- Take care of the orientation of the guide rib.
- Ensure that you do not drop the guide rib inside the machine.

Close the feeder cover.

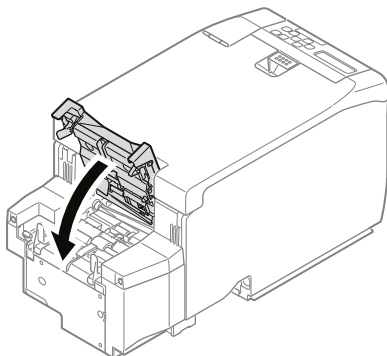

Loading Paper



Set the roll paper its side on a flat surface so that it dose not roll or fall. Dropping a roll paper may cause injury.

- Be careful not to soil the printing surface of the roll paper. The print quality may deteriorate.
- It is recommended to wear and handle clean cloth gloves etc. to protect the printing surface of the roll paper.
- Align the edges of the paper on both ends of the roll paper. This may cause paper feed problems.

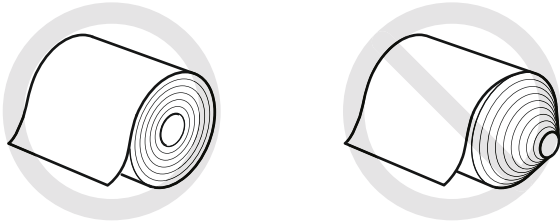

Before loading the roll paper, remove any paper from the paper inlet unit.

- Do not load the roll paper in the opposite direction.
- If a feeding problem occurs, reload the roll paper.
- When the roll paper is in one of the following conditions, cut off the edge of the paper with scissors before loading it. This may cause paper feed problems and affect the printing quality.

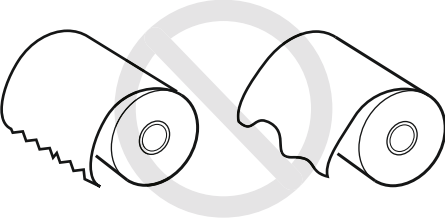
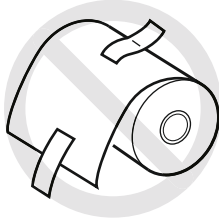
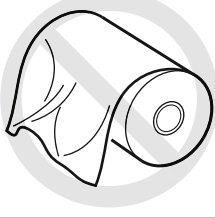
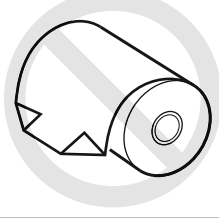
<p>The leading edge of the roll paper is damaged.</p> 	<p>Adhesive tape, glue or dirt is sticking to the roll paper.</p> 
<p>The roll paper is wrinkled.</p> 	<p>The corners of the roll paper are folded.</p> 
<p>The roll paper curls in the opposite direction to the rolling direction.</p>	<p>The edge of the roll paper is dented.</p>

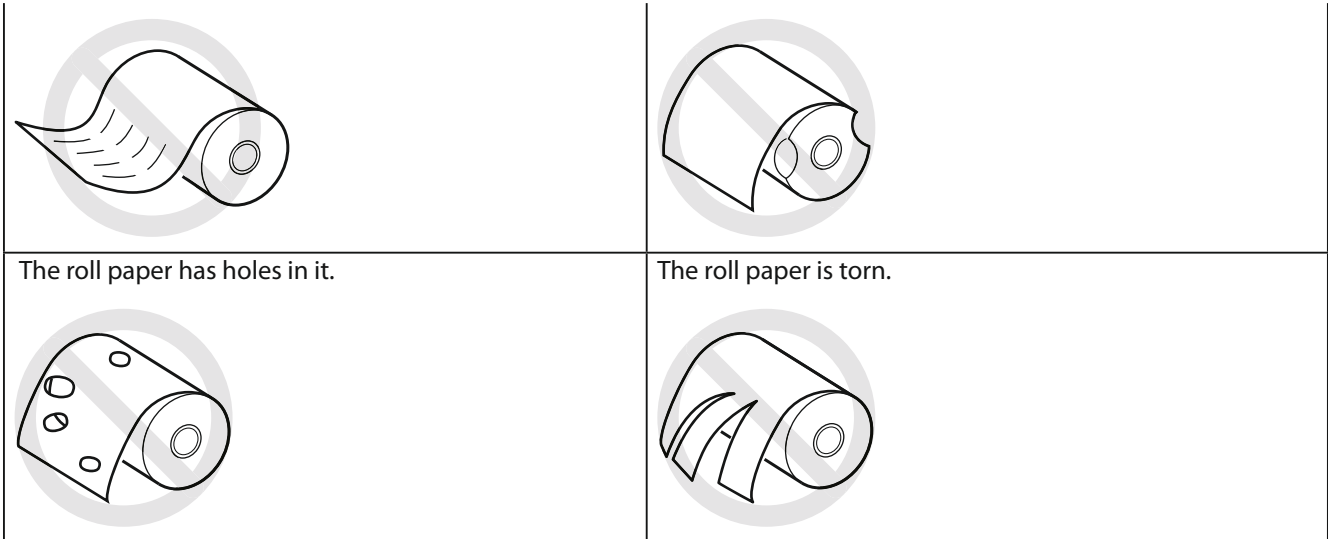

- When cutting the leading edge of the paper with scissors, cut the paper vertically to the feed direction, so that it can be fed into the machine.
- Be careful not to cut through any barcodes printed on the roll paper.
- You cannot use the roll paper that its edge is dented.

Set the upper and lower paper sensors in the appropriate positions.

- ▶ For details, refer to “Setting the Paper Sensors”.

Insert your finger below the gray lever on the left of the machine rear, and lift it up to open the feeder cover.

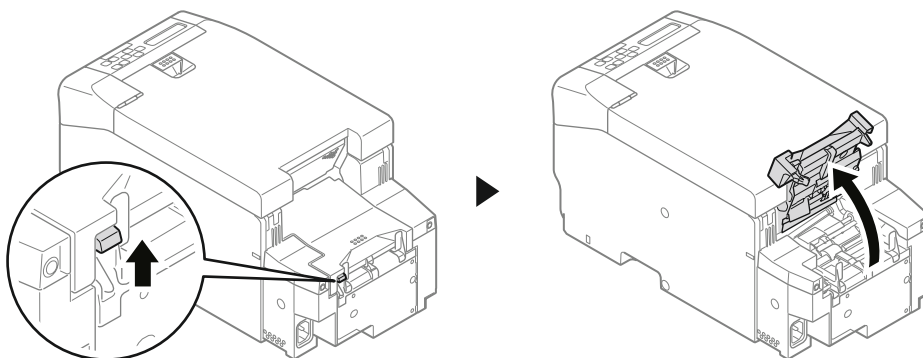

Turn up the paper guide lever on the left side on the front of the machine to unlock it.

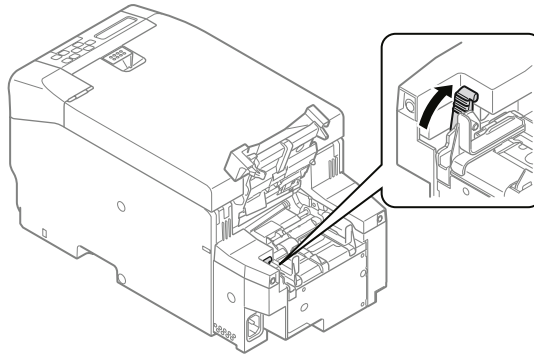

Align the paper guide with the paper width.

- ▶ Adjust the paper guide so that there is no gap between it and the paper.

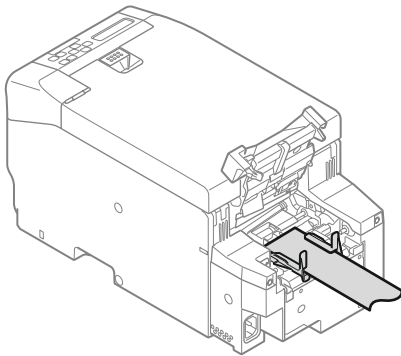

Turn down the paper guide lever toward you to lock it.

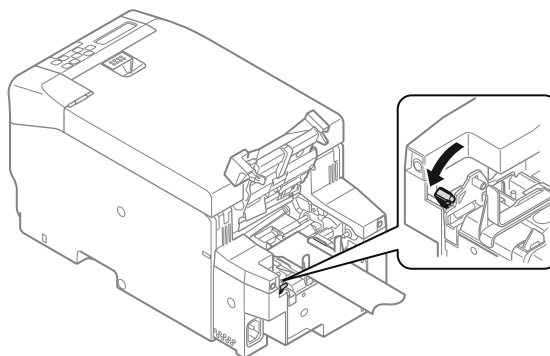

Remove the paper temporarily, and close the feeder cover.

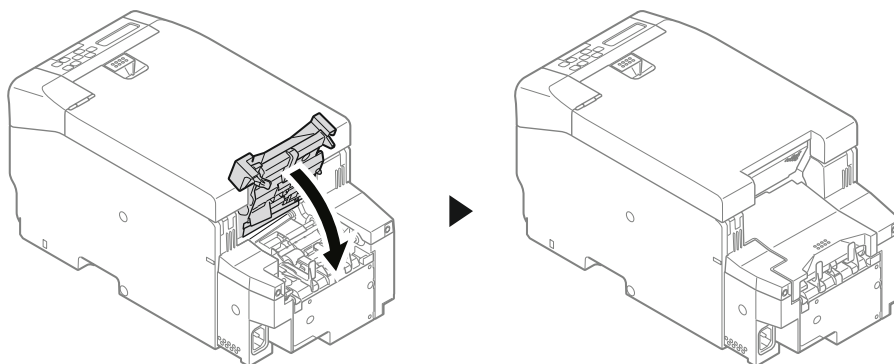

Insert the paper into the inlet until it stops.

▶ The paper is automatically loaded.

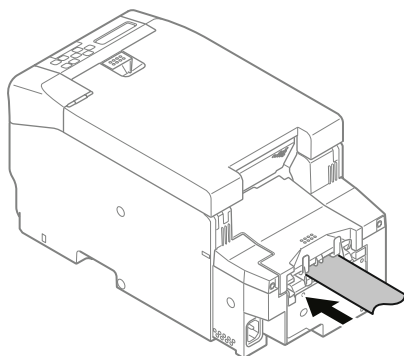

Feeding the Paper

Feeding is performed for the paper set in the machine according to the machine settings.

Execute feeding in the following cases. Printing may not be able to be performed correctly unless feeding is performed.

- When paper is set in the machine again because it had run out, etc.
- When paper was cut at the appropriate position because of a paper jam, etc.
- When the cut position setting is changed
-

When the tip of the paper is dirty, performing paper feeding to cut off the dirty part with the paper still loaded in the machine.

When the paper to print on has been changed to another paper type, execute sensor calibration.

- Confirm that paper is loaded in the machine.
- Confirm that [READY TO PRINT] is displayed on the machine.

-
- Press «FEED/CUT» button.

When a paper jam occurs during printing, the paper may be removed from the machine in order to clear the paper jam.

When paper is set in the machine again after clearing a paper jam, a screen similar to the following is displayed.

Press «FEED/CUT» button while this screen is displayed to execute paper feeding.

RESTART PRINT?
OK OR FEED/CUT

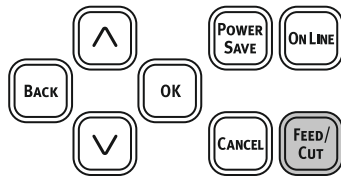

Registering Paper Information to the Printer Driver

Register the information for the paper to use.

- Click [Start], and select [Control Panel] in [Windows System].
- Click [View devices and printers].
- Right-click the [cCX86e PCL6] icon, and select [Printing Preferences].
- Click [User-defined paper] on the [Setup] tab.

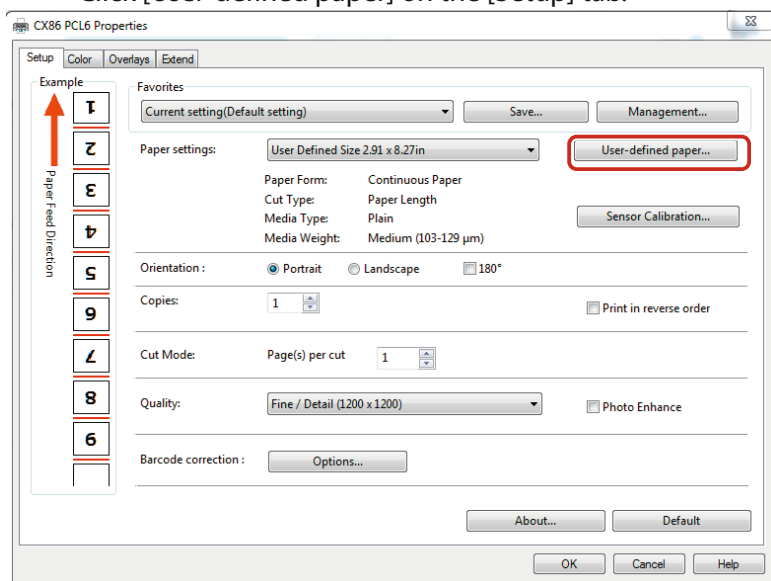

Enter the information for the paper to register.

- (1) Select [New Paper] from [Registered User-defined paper].
- (2) Enter the paper name in [Paper Name].
- (3) Select the paper format.
- (4) Select the cut type.
- (5) Select the paper type.
- (6) Select the paper weight.
- (7) Enter the paper size information.
 - ▶ Enter the paper size information after measuring the paper with a ruler, where possible.
 - ▶ Select [Hole Position Center] if the paper has a hole in the center.

Click [Add] when all the information has been entered.

Adjusting the Paper Sensors (Sensor Calibration)

If paper jams or paper mark detection errors occur frequently, follow the procedure below to perform sensor calibration.

It adjusts the paper sensors to the position suitable for the paper to use.



For details, refer to "Setting the Paper Sensors".



The paper sensors cannot be correctly calibrated unless they are in a suitable position.

- Confirm that [READY TO PRINT] is displayed on the machine.
- Click [Start] on the computer, and select [Control Panel] in [Windows System].
- Click [View devices and printers].
- Right-click the [CX86e PCL6] icon, and select [Printing Preferences].
- Click [Sensor Calibration...] on the [Setup] tab.
- Remove the paper from the machine when [Would you like to execute sensor calibration] is displayed.
- Click [Execute] on the printer driver screen of the computer.
- Load the paper in the machine when [PLEASE LOAD PAPER] is displayed on the screen of the machine.
- The procedure is complete when [READY TO PRINT] is displayed.



- Remove the paper in the machine when [PLEASE REMOVE PAPER] is displayed on the screen. Failing to do so will cause a paper detection error. The paper detection error can be cleared by opening and closing the cover.
- Sensor calibration cannot be performed from the printer driver while the machine has print data or while [PLEASE LOAD PAPER] is displayed on the screen.
- An execution error occurs unless paper is loaded within one minute of [PLEASE LOAD PAPER] being displayed. The execution error can be cleared by opening and closing the cover.
- When you change the paper to use, it is recommended that you execute sensor calibration.

Printing from a Computer

Wordpad is used here as an example.

- Load the paper.
 - ▶ For details, refer to "Chapter 5 Loading Paper".
- Open the file to print.
- Select [Print] from the [File] menu.
- Select [CX86e] as the printer, and click [Preferences].
- Select the paper to use in [Paper Settings] on the [Setup] tab.
 - ▶ If the paper to use does not exist, click [User-defined paper] and register the paper. For details, refer to "Registering Paper Information to the Printer Driver".
- Select the items to set on each tab, and click [OK].
- Click [Print].
-

Printer Driver Screens and Functions

This section describes the functions of the printer driver.

The printer driver screen is displayed by opening the file to print and clicking [Print] - [Preferences] in the [File] menu.

[Setup] Tab

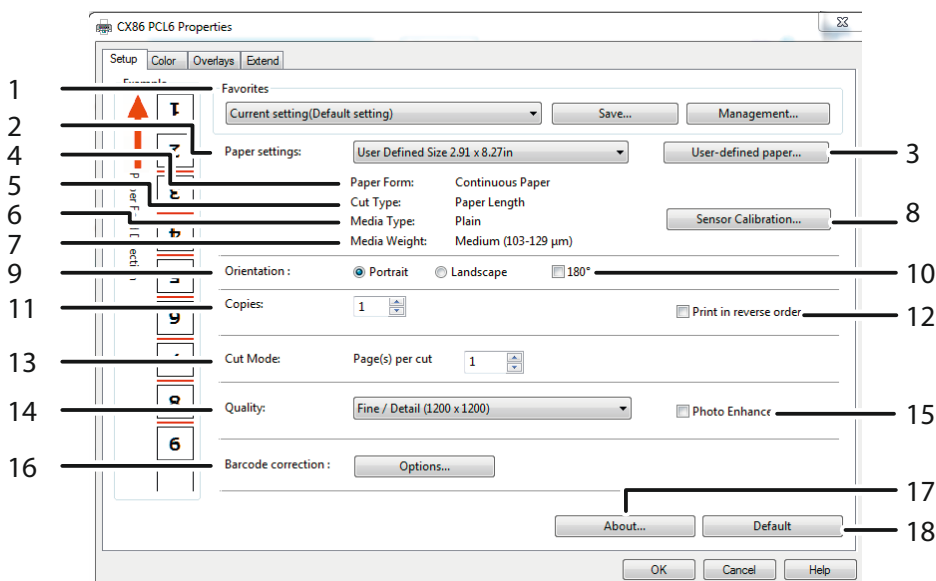

No.	Item	Description
1	Favorites	Enables the printer driver settings to be saved to a file.
2	Paper settings	Sets the paper to print on.
3	User-defined paper	Adds, changes, and deletes paper.
4	Paper Form	Displays the paper format set for the user-defined paper.
5	Cut Type	Displays the cut type set for the user-defined paper.
6	Media Type	Displays the paper type set for the user-defined paper.
7	Media Weigh	Displays the paper weight set for the user-defined paper.
8	Sensor Calibration	Adjusts the sensors used for detecting paper and marks.
9	Orientation	Sets the orientation for printing on the paper.
10	180 turn	Prints with the orientation rotated 180 degrees.
11	Copies	Enter the number of copies to print at once
12	Print in reverse order	Cuts every specified number of pages.
13	Cut Mode	Sets the resolution for printing.
14	Quality	Prints the image data for photos, etc. in detail.
15	Photo Enhance	Configures settings for improving the accuracy of reading barcodes.
16	Barcode correction	Displays the version information of the printer driver.
17	About	Displays the version information of the printer driver.
18	Default	Restores the default settings of this tab.

[Color] Tab

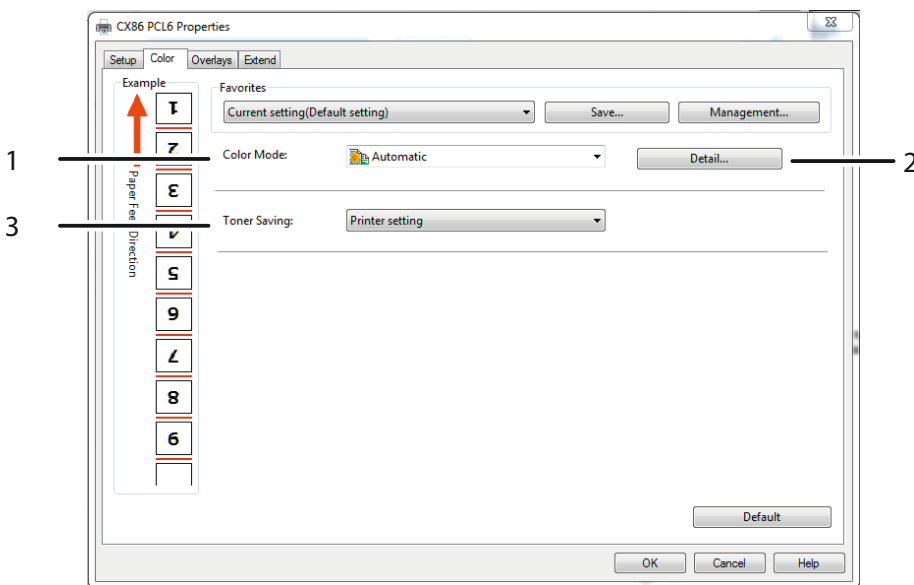

No.	Item	Description
1	Color Mode	Displays the color mode set with the [Detail] button.
2	Detail	Configures settings related to color printing.
3	Toner Saving	Configures settings related to saving toner when printing.

[Overlays] Tab

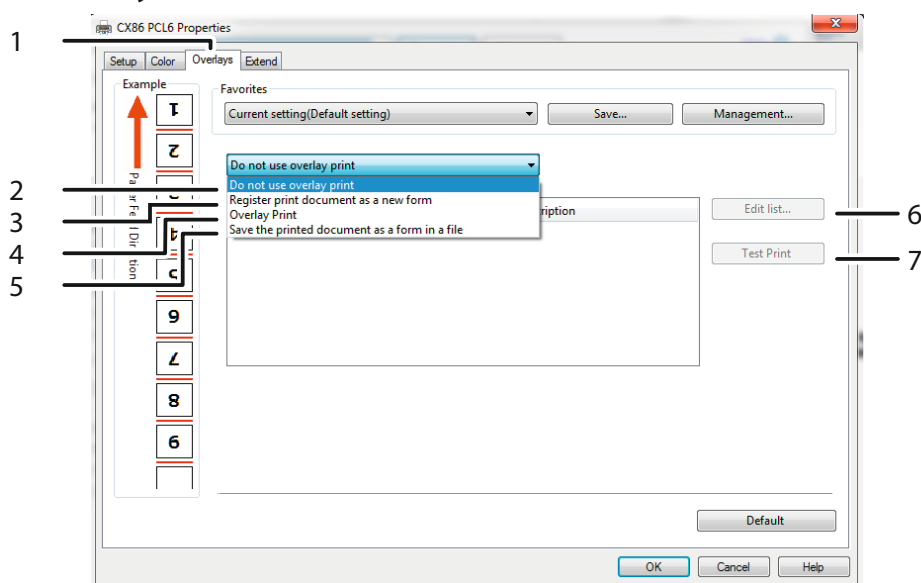

No.	Item	Description
1	Overlay	Selects whether to print the document with a form overlaid, register the document to print to the printer as a new form, or save the document to a file as a form.
2	Do not use overlay print	Prints documents without overlaying a form.
3	Register print document as a new form	Registers the document to print to the printer as a new form.
4	Overlay Print	Overlays the selected form or group to the document to print.
5	Saving the printed document as a form in a file	Saves the document to print as a file in the form format.
6	Edit list	Sets the list of overlays that can be selected for overlay printing.
7	Test Print	Prints the selected form only.

[Extend] Tab

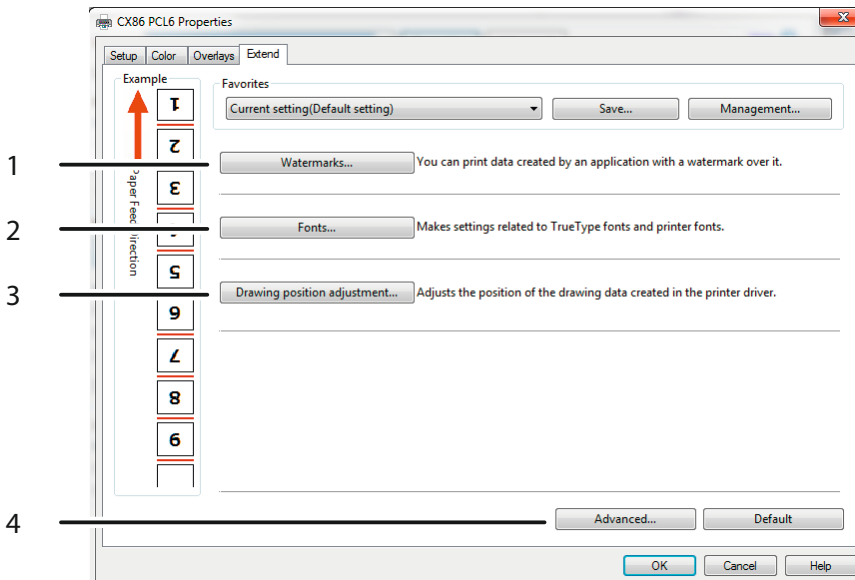

No.	Item	Description
1	Watermarks	You can print data created by an application with a watermark over it.
2	Fonts	Configures settings related to TrueType fonts and printer fonts.
3	Drawing position adjustment	Adjusts the position of the drawing data created by the printer driver.
4	Advanced	When the desired print results are not obtained, this may enable them to be produced, depending on the symptom.

Registering Frequently Used Settings (Favorites)

Registering frequently used settings to favorites with a name eliminates the need for changing the settings each time printing is performed. Select the registered name when printing.

- Open the file to print.
- Select [Print] from the [File] menu.
- Click [Preferences].
- Change the items on each tab to the values you want to set.
- Click [Register].
- Enter the setting name in [Setting Name], and click [OK].
- Click [OK] to close the print settings dialog.
- To print with the registered settings, select the name registered in [Favorites], and perform printing.

Specifying the Print Orientation

Perform the procedure below to change the print orientation.

- Open the file to print.
- Select [Print] from the [File] menu.
- Click [Preferences].
- Select the desired print orientation in [Orientation] on the [Setup] tab.
- Click [OK].
- Click [Print].

Rotating the Print Result 180 Degrees

You can change the settings of the printer driver to rotate the print result by 180 degrees, without changing the file to print.

- Open the file to print.
- Select [Print] from the [File] menu.
- Click [Preferences].
- Select [180°] in [Orientation] on the [Setup] tab.
- Click [OK].
- Click [Print].

Specifying the Number of Prints

Available values are from 1 to 999.

- Open the file to print.
- Select [Print] from the [File] menu.
- Click [Preferences].
- Enter the number of prints in [Copies] on the [Setup] tab.
- Click [OK].
- Click [Print].

Printing from the Last Page

The document will be in page order if the print results are stacked with the printed surface facing up.

- Open the file to print.
- Select [Print] from the [File] menu.
- Click [Preferences].
- Select [Print in reverse order] on the [Setup] tab.
- Click [OK].
- Click [Print].

Cutting Every Specified Number of Pages

You can cut the paper every specified number of pages.

Specify the position to cut the paper when using continuous paper.

- Open the file to print.
- Select [Print] from the [File] menu.
- Click [Preferences].
- Enter the number of pages to cut the paper at in [Page(s) per cut] in [Cut Mode] on the [Setup] tab.
- Click [OK].
- Click [Print].

When [Hole] is selected in [Cut Type], [Cut by Page] is always set to [1].

You cannot specify a number of pages that exceeds a total of 551 mm in paper length.

Changing the Print Quality

Perform the procedure below to change the print quality.

- Open the file to print.
- Select [Print] from the [File] menu.
- Click [Preferences].
- Select a value of your choice in [Quality] on the [Setup] tab.
- Click [OK].
- Click [Print].

Printing with the Photo Mode

Perform the procedure below to print the image data of photos in detail.

- Open the file to print.
- Select [Print] from the [File] menu.
- Click [Preferences].
- Select [Photo Enhance] on the [Setup] tab.
- Click [OK].
- Click [Print].

Correcting Barcodes for Printing

Perform the procedure below to improve the accuracy of reading barcodes.

- Open the file to print.
- Select [Print] from the [File] menu.
- Click [Preferences].
- Click [Preferences] in [Barcode Correction] on the [Setup] tab.
- Select a value in [Bar Width Adjustment].
 - ▶ The print results of images and illustrations other than barcodes may become thinner.
 - ▶ If selected, colors may overlap or unintended colors may be printed when printing in color.
- Select [Replace mono barcode with cyan] as necessary.
 - ▶ Black or grey parts may be replaced by cyan when printing images or figures other than barcodes.
 - ▶ If selected, colors may overlap or unintended colors may be printed when printing in color.
 - ▶ May become disabled when greyscale is set from the application.
- Click [OK].
- Click [Print].

Changing the Color Settings

You can adjust color printing.

- Open the file to print.
- Select [Print] from the [File] menu.
- Click [Preferences].
- Select a value of your choice in [Color Mode] on the [Color Settings] tab.
- Click [OK].
- Click [Print].

Reducing Toner Consumption When Printing

You can reduce the toner consumption when performing test prints, etc.

- Open the file to print.
- Select [Print] from the [File] menu.
- Click [Preferences].
- Select a value in [Toner Saving] on the [Color Settings] tab.
- Click [OK].
- Click [Print].

Overlaying Text or Logos When Printing

You can print on forms registered in the machine in advance.

- Register the forms to the machine.
 - ▶ For details, refer to “Saving Documents to Print as Files in the Form Format”.
- Open the file to print.
- Select [Print] from the [File] menu.
- Click [Preferences].
- Select the [Overlays] tab.
- Select [Overlay Print] from the pull-down menu, and select the form to use for overlay printing from the drop-down list.
 - ▶ When adding a form registered in the Configuration Tool or overlaying multiple forms as a group, click [Edit List] to add them to the list.

To add a form registered in the Configuration Tool: Click [Add a registered form], enter the form name in [Form name] and the form ID registered in the Storage Manager plug-in of the Configuration Tool in [ID], select the pages to apply that form to in [Print on Pages], and click [OK].

- Click [OK].
- Configure the settings as required, and click [OK].
- Click [Print] on the [Print] screen.

Registering Print Documents as New Forms

Before performing overlay printing, perform the procedure below to register the forms.

You can register up to 32 forms.

- Create the forms to register to the printer in an application.
- Select [Print] from the [File] menu.
- Click [Preferences].
- Select [Register print document as a new form] from the pull-down menu on the [Overlays] tab.
- Click [OK].
- Configure the settings as required, and click [OK].
- Click [Print] on the [Print] screen.
- Enter the [Form name] and [ID] to register to the printer in [New Form].
 - ▶ The position for performing overlay printing can also be specified.
- Select the page to apply the overlay to in [Print on Pages] as the registration information for the printer driver.

To specify the pages to apply, select [Custom], and enter the pages to apply in [Custom Pages].

- Click [OK].

Saving the Documents to Print as Files in the Form Format

You can save the documents to print as files in the form format.

- Create the forms to register to the printer in an application.
- Select [Print] from the [File] menu.
- Click [Preferences].
- Select [Save the printed document as a form in a file] from the pull-down menu on the [Overlays] tab.
- Click [Use] and select the destination.

-
- Click [OK].
 - Configure the settings as required, and click [OK].
 - Click [Print] on the [Print] screen.
 - In [Save the form with a name], enter [ID] and click [OK].

 The position for performing overlay printing can also be specified.

- Click [OK].

 Forms do not include a watermark.

Printing Hidden Text (Watermarks)

You can overlay user-defined text over files to print.

- Open the file to print.
- Select [Print] from the [File] menu.
- Click [Preferences].
- Click [Watermark] on the [Extend] tab.
- Click [New].
- Enter the characters to print in [Text] on the [Watermarks] screen.
- Configure [Font], [Size], and the other settings as required, and click [OK].
- Confirm that the watermark to print is selected, and click [OK].
- Configure the settings as required, and click [OK].
- Click [Print] on the [Print] screen.

Printing with a Specified Font

You can print by specifying a font in a computer or the machine.

- Open the file to print.
- Select [Print] from the [File] menu.
- Click [Preferences].
- Select the [Extend] tab.
- Click [Font].
- Select the print method in [TrueType Font Output Type].
- Click [OK].
- Configure the settings as required, and click [OK].
- Click [Print] on the [Print] screen.

Adjusting the Rendering Position

Perform the procedure below to adjust the position of the render data.

- Open the file to print.
- Select [Print] from the [File] menu.
- Click [Preferences].
- Click [Adjustment] on the [Extend] tab.
- Enter the vertical (Y) and horizontal (X) values on the [Adjustment] screen, and click [OK].
- Click [OK].
- Click [Print] on the [Print] screen.

Reducing the Size of Spool Files (Disabling EMF)

The following procedure may be effective for reducing the time until processing is returned to the application after printing starts.

- Open the file to print.
- Select [Print] from the [File] menu.
- Click [Preferences].
- Click [Advanced] on the [Extend] tab.
- On the [Advanced] screen, click [Reduce Size of Spool File], and select [ON] from the [Settings] drop-down box.
- Click [OK].
- Click [OK].
- Click [Print].

Keeping the Page Layout when Resizing a Document

The following procedure may be effective for maintaining the page layout when printing with a zoom ratio.

- Open the file to print.
- Select [Print] from the [File] menu.
- Click [Preferences].
- Click [Advanced] on the [Extend] tab.

-
- On the [Advanced] screen, click [Keep page layout when resizing document], and select [ON] from the [Settings] drop-down box.
 - Click [OK].
 - Click [OK].
 - Click [Print].

Correcting Faintness in Thin Lines and Small Text

Perform the procedure below to improve faintness in thin lines and small text.

- Open the file to print.
- Select [Print] from the [File] menu.
- Click [Preferences].
- Click [Advanced] on the [Extend] tab.
- On the [Advanced] screen, click [Adjust ultra fine lines], and select [ON] from the [Settings] drop-down box.
- Click [OK].
- Click [OK].
- Click [Print].



If the expansion of curved lines causes barcodes to become smudged, setting this to [OFF] may improve the problem.

Executing Drum Cleaning Before Printing

Perform the procedure below to execute drum cleaning before printing.

- Open the file to print.
- Select [Print] from the [File] menu.
- Click [Preferences].
- Click [Advanced] on the [Extend] tab.
- On the [Advanced] screen, click [Run maintenance cycle before printing], and select [ON] from the [Settings] drop-down box.
- Click [OK].
- Click [OK].
- Click [Print].

Skipping Blank Pages

You can skip the printing of blank pages to save paper.

- Open the file to print.
- Select [Print] from the [File] menu.
- Click [Preferences].
- Click [Advanced] on the [Extend] tab.
- On the [Advanced] screen, click [Skip White Pages], and select [ON] from the [Settings] drop-down box.
- Click [OK].
- Click [OK].
- Click [Print].

Printing Using the Presenter Unit

Using the optional Presenter Unit enables printed paper to be retained in the outlet without being output.

The following operation modes exist.

MODE1: Retain the printed paper in the outlet. Printing of the next paper starts when the printed paper is removed.

MODE2: The last printed paper is retained in the outlet and output when the next printing starts. The last paper is retained in the outlet until the next printing starts.

OFF : Output the printed paper without retaining it.

Setting the Mode

- Install the Presenter Unit.



For details, refer to “Installing the Presenter Unit”.

- Turn on the machine.



For information on turning on the machine, refer to “Turning On the Machine”.

- Confirm that [READY TO PRINT] is displayed on the machine.
- Press \wedge button or \vee button several times to display [ADMIN SETUP], and press «OK» button.
- When [ENTER PASSWORD] is displayed, enter the password.



The default password is “999999.”

-
- When the password has been entered, press «OK» button.
 - Press ^ button or v button several times to display [PRINT SETUP], and press «OK» button.
 - Press ^ button or v button several times to display [PRESENTER MODE], and press «OK» button.
 - With the setting flashing, press ^ button or v button to display the value you want to set, and press «OK» button.
 - Press «ONLINE» button, or press «BACK» button until [READY TO PRINT] is displayed.

When Set to MODE1

- Open the file to print.
- Select [Print] from the [File] menu.
- Click [Preferences].
- Select the items to set on each tab, and click [OK].
- Click [Print].
- When the printed paper stops near the Presenter Unit, check the operation panel and pull out the paper.
- Repeat step 6 until all pages have been printed.
- Pull out the final page that has stopped near the Presenter Unit.

When Set to MODE2

- Open the file to print.
- Select [Print] from the [File] menu.
- Click [Preferences].
- Select the items to set on each tab, and click [OK].
- Click [Print].
- Pull out the final page that has stopped near the Presenter Unit.



- The machine does not enter the Power Save mode when it is retaining the printed paper.
- If the printed paper is not fully ejected, check whether the settings in [PRESENTER MODE] and [PRESENTER UNIT]

on the operation panel match your environment.

Removing the Windows Printer Driver

 You must log in as the administrator to perform this procedure.

- Restart the computer.
- Click [Devices and Printers].
- Right-click the icon for the printer to delete, and select [Remove device].

If the icons are grouped, select [Remove Print Queue] > [CX86e PCL6].

- When a confirmation message is displayed, click [Yes].

 When a message is displayed to inform you of the device in use, repeat steps 1 to 3.

- Select an icon in [Printers], and click [Print server properties] on the top bar.
- Select the [Driver] tab.
- If [Change Driver Settings] is displayed, click it.
- Select the printer driver to be removed, and click [Delete].
- If the [Remove Driver and Package] screen is displayed, select [Remove driver and driver package], and click [OK].
- When a confirmation message is displayed, click [Yes].
- When the [Remove Driver Package] screen is displayed, click [Delete] > [OK].





 If removal is rejected, restart the computer, and then repeat steps 4 to 10.







- Click [Close] in the [Print Server Properties] screen.
- Restart the computer.







Replacing Consumables

Cautions for Replacing Consumables

Observe the following cautions when replacing consumables.

 WARNING	
	Do not throw toner or a toner cartridge into a fire. The toner will scatter, resulting in burns.
	Do not store a toner cartridge in a location where it is exposed to fire. The toner may ignite, resulting in fire or burns.
	Do not vacuum spilled toner with an electric vacuum cleaner. Vacuuming spilled toner with an electric vacuum cleaner may result in ignition due to sparks from electric contacts or other reasons. If toner spills on the floor or other places, wipe the toner with a damp rag or other cloth.

 CAUTION	
	Some parts inside the machine become very hot. Do not touch the locations around a "CAUTION HOT" label. This may cause burns.
	Keep toner cartridges out of the reach of children.
	If you inhale toner, gargle with a large amount of water, and move to a place with fresh air. Also seek medical advice, as required.
	If toner stains your hands or other areas of skin, wash thoroughly with soap and water.
	If toner gets into your eyes, immediately rinse them with a large amount of water. Also seek medical advice, as required.

 CAUTION	
	If toner is swallowed, seek medical advice, as required.
	When handling a paper jam or replacing toner cartridges, use care not to let your clothes or hands get dirty with toner. If toner stains your clothes, wash with cold water. If you warm the stained clothes by washing them with hot water or other methods, the toner will soak into the fabric and become impossible to remove.
	Do not disassemble or forcibly open the image drum or toner cartridges. The toner may be scattered, causing you to inhale the toner or get your hands or clothes stained with the toner.
	Keep a used toner cartridge in a bag so that the toner is not scattered.
	If toner is spilled on the floor, gently wipe it away with a wet rag, etc. to ensure that the toner does not scatter.

- Use genuine DTM Print GmbH consumables to ensure product performance.
- Problems caused by using non-genuine consumables require a payment, regardless of the warrant or maintenance contract. (Although use of non-genuine consumables does not always result in problems, be extremely careful when using them.)

Replacing the Toner Cartridge

When "ORDER TONER" is displayed on the screen of the operation panel, prepare a replacement toner cartridge.

When "REPLACE TONER" is displayed and printing is stopped, replace the toner cartridge.



- The print quality deteriorates after one year or more passes since you open the toner cartridge. In this case, prepare a new toner cartridge for replacement.
- If you replace the toner cartridge/image drum unit while it is being used, the amount of toner used will not be counted accurately.

Open the toner cartridge cover.

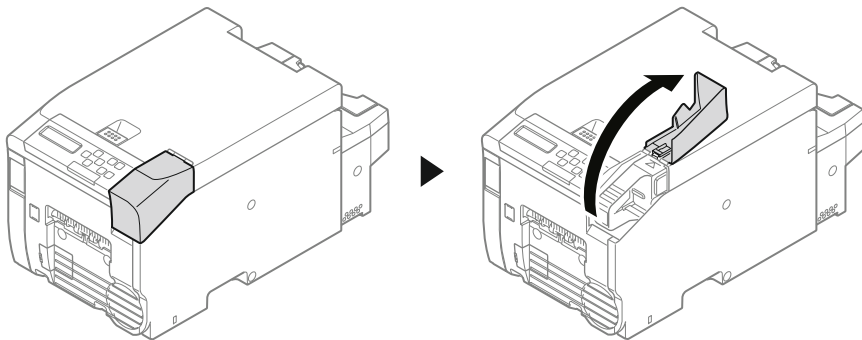

- Pull out the toner cartridge.



WARNING

Burns may result.



Never throw used toner cartridges into a fire. They may explode, and the toner inside may be scattered and cause burns.



- Place paper under the removed toner cartridge, as toner may leak from the bottom.

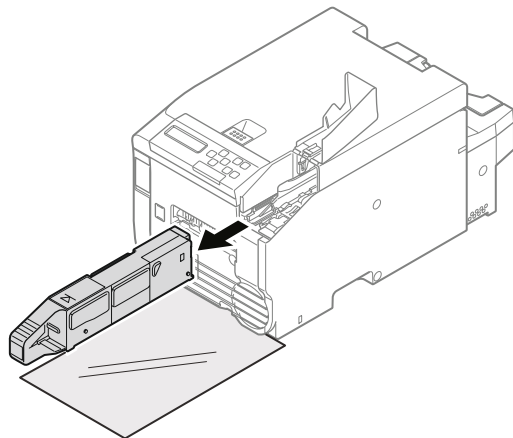

- Take out the new toner cartridge, and shake it several times vertically and horizontally.

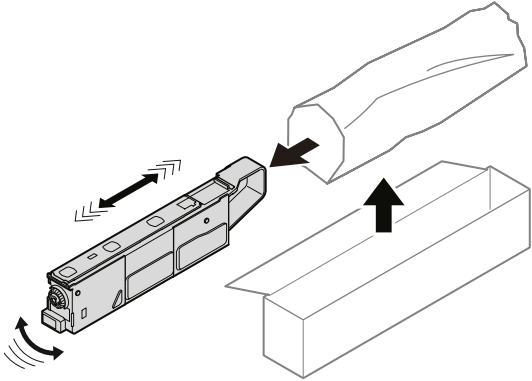

- Place the toner cartridge in the direction that it will be attached to the machine.

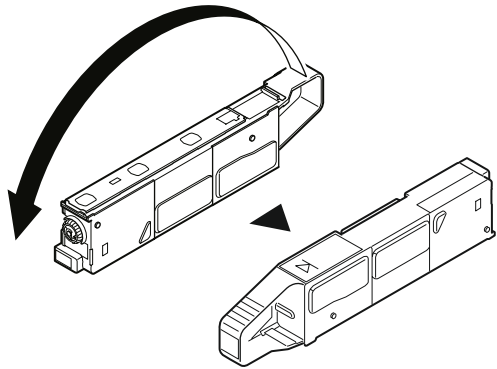

- Attach the toner cartridge.

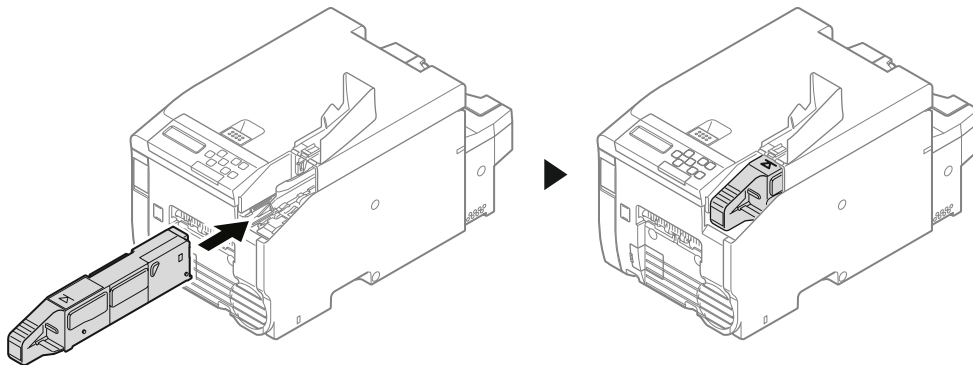

- Close the toner cartridge cover.

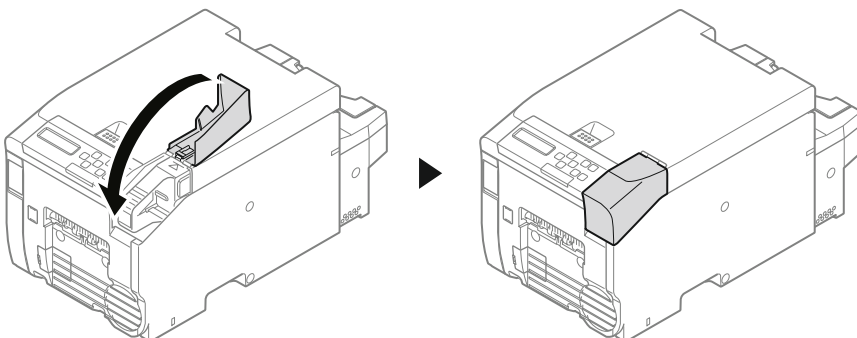

Replacing the Image Drum Unit

When "ORDER IMAGE DRUM" is displayed on the screen of the operation panel, prepare a replacement image drum unit.

If you continue printing, "IMAGE DRUM LIFE" is displayed and printing stops.

When "IMAGE DRUM LIFE" is displayed and printing stops, replace the image drum unit.

The estimated replacement cycle of an image drum unit is approximately 25,000 pages for 216 mm simplex printing (one page per job).



- The actual number of pages you can print with the image drum unit depends on how you use the machine. It may be less than half the above estimation depending on the printing conditions.
- Printing quality of the toner cartridge may deteriorate after one year has passed since unpacking. Replace the image drum unit with a new one.
- Even after "IMAGE DRUM LIFE" is displayed, you can continue printing, but we recommend you replace the unit immediately when "REPLACE IMAGE DRUM" is displayed.
- The "ORDER IMAGE DRUM" message is not displayed when [ADMIN SETUP] > [PANEL SETUP] > [NEARLIFE STATUS] is set to [DISABLE].
- Use genuine DTM Print GmbH consumables to ensure product performance.
- Problems caused by using non-genuine consumables require a payment, regardless of the warrant or maintenance contract. (Although use of non-genuine consumables does not always result in problems, be extremely careful when using them.)

- Use extra care when handling the image drum (the glossy cylinder), because it is fragile.
- Do not expose the image drum unit to direct sunlight or strong light (approximately 1,500 lux or more). Do not leave the image drum unit exposed for 5 minutes or more, even under room lighting. When the image drum unit will be left alone for 5 minutes or more, cover it with black paper, etc. to prevent it from being exposed to light.
- You can change the timing for displaying the "ORDER IMAGE DRUM" message. Set it using [ADMIN SETUP] > [OTHERS SETUP] > [NEARLIFE SETUP] > [DRUM NEARLIFE] on the operation panel. Available values are from 500 to 5,000 (in 500 increments).

Turn off the machine.

- For information on turning off the machine, refer to "Turning Off the Machine".
- Insert your finger into the recess on the top of the machine and pull up the lever.

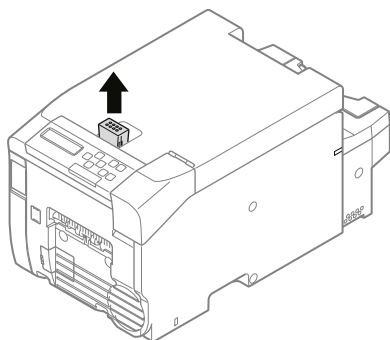

- Open the top cover until it stops.

	<p>CAUTION Burns may result.</p>	
<p>The fuser unit is extremely hot. Do not touch it.</p>		

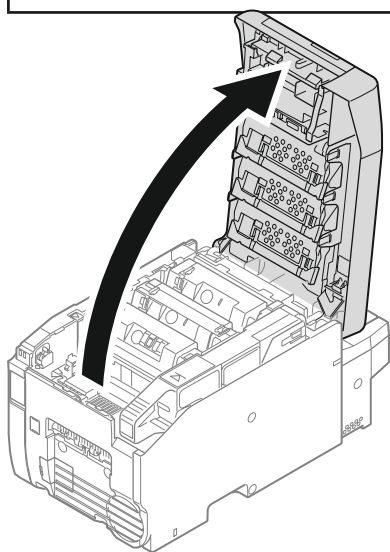

- Hold the blue handle and pull out the image drum unit vertically.



- Pull it out after opening the top cover fully.

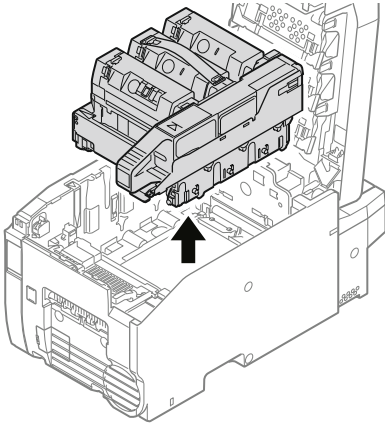

- Hold the blue handle of a new image drum unit, confirm the position to install it to the machine, and lower it vertically.

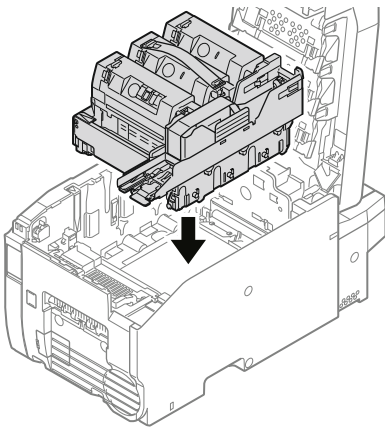

- Peel off the protective tape.

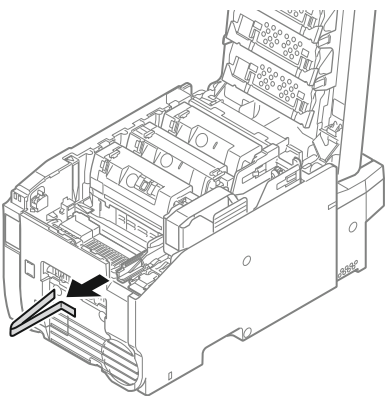

- Peel off the protective tape, and remove the desiccant.

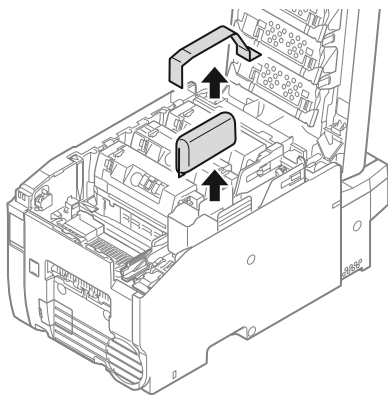

- Remove the cover toner.

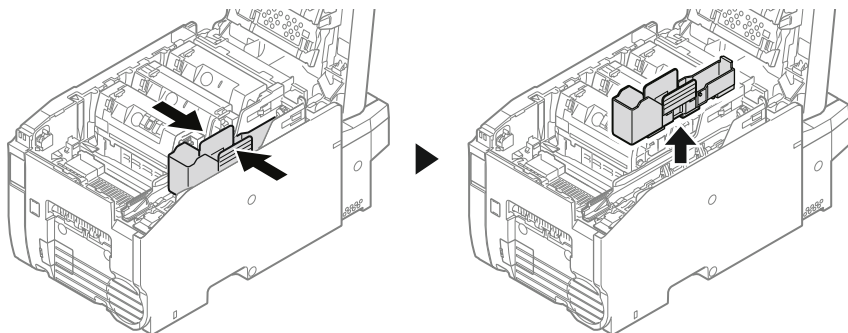

- Close the top cover.

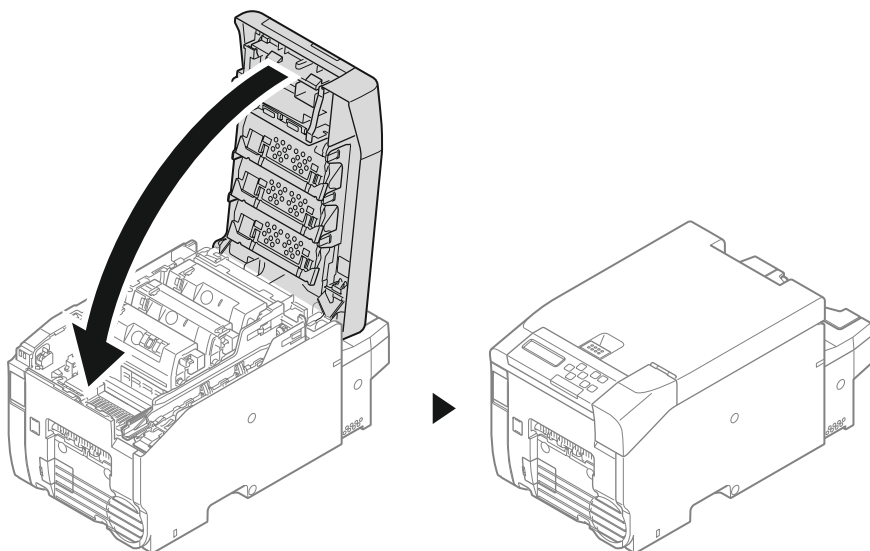

- Open the toner cartridge cover.

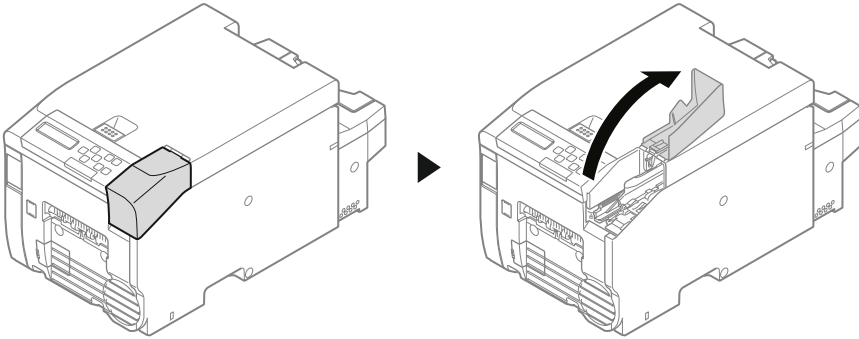

- Take out the new toner cartridge from the packaging bag, and shake it several times vertically and horizontally.

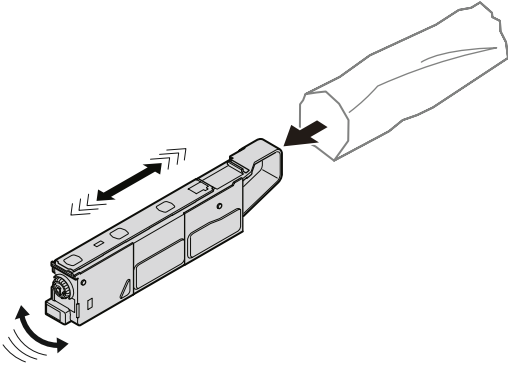

- Place the toner cartridge in the direction that it will be attached to the machine.

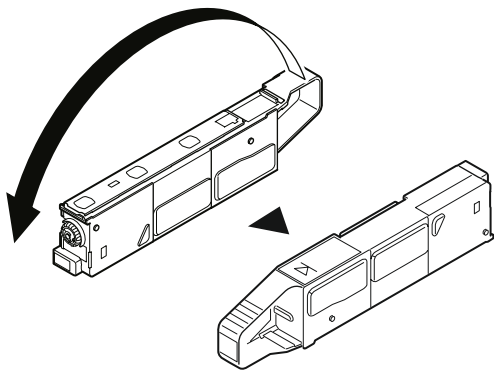

- Attach the toner cartridge.

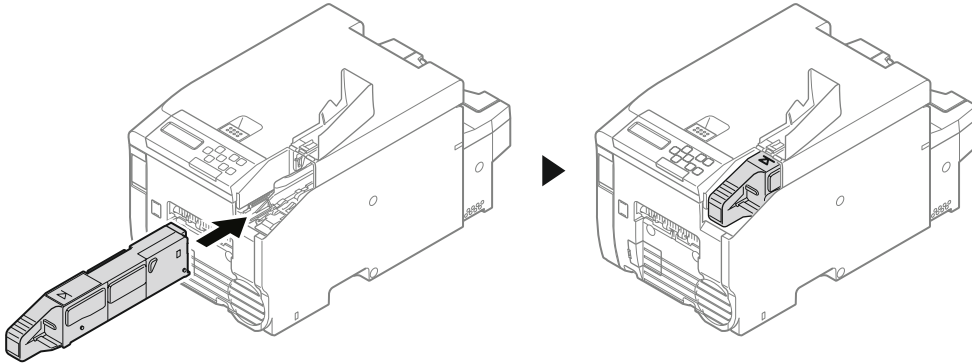

- Close the toner cartridge cover.

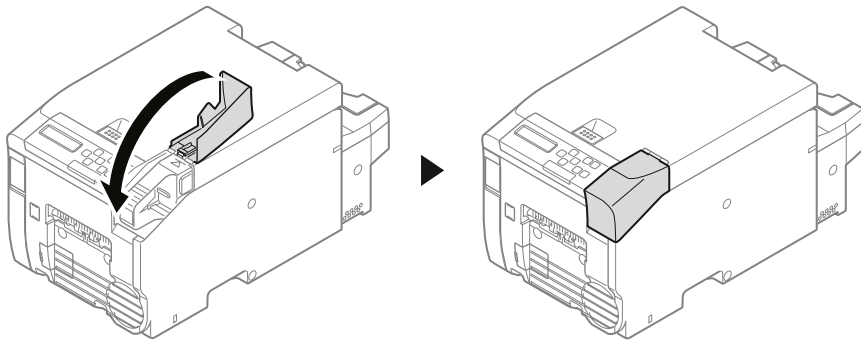

- Turn on the machine.



- For information on turning on the machine, refer to "Turning On the Machine".

When the Lightproof Film Is Dirty

When the lightproof film of the image drum unit is dirty, wipe it clean with a soft tissue.

Insert your finger into the recess on the top of the machine and pull up the lever.

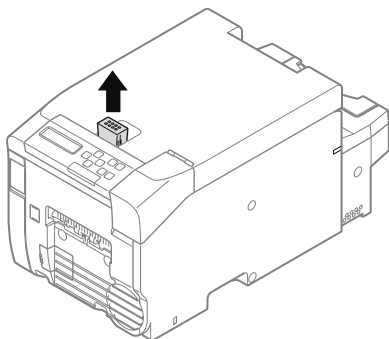

- Open the top cover until it stops.

CAUTION Burns may result.



The fuser unit is extremely hot. Do not touch it.

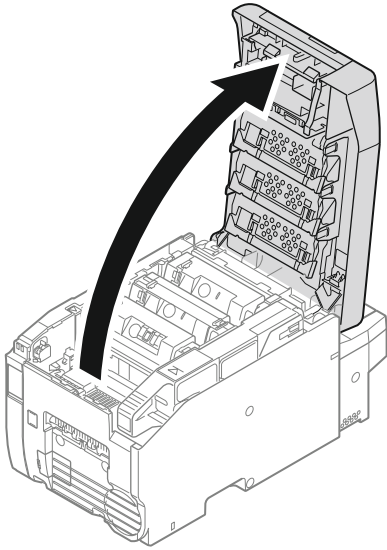

- Wipe the lightproof film with a soft tissue paper lightly.

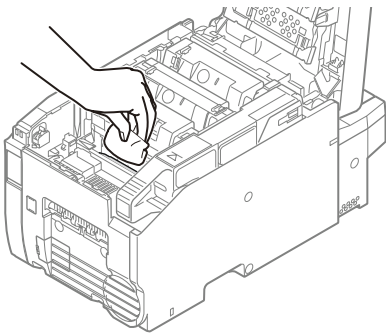

Replacing the Fuser Unit

When "ORDER FUSER UNIT" is displayed on the screen of the operation panel, prepare a replacement fuser unit. The estimated timing for the next message to be displayed is when printing approximately 5,000 pages.

When "FUSER UNIT LIFE" is displayed, replace the fuser unit.

The estimated replacement cycle of the fuser unit is approximately 100,000 pages for 216 mm simplex printing (one page per job).



- The actual number of pages you can print with the fuser unit before replacement depends on how you use it.
- Even after "FUSER UNIT LIFE" is displayed, you can extend the lifetime of the fuser unit somewhat by opening and closing the cover, etc., but we recommend you replace the fuser unit soon to prevent malfunction.
- Replace the fuser unit after you use it up to the end of its lifetime. If you use the removed fuser unit with another device, its lifetime will not be displayed correctly.

- "ORDER FUSER UNIT" is not displayed when [ADMIN SETUP] > [PANEL SETUP] > [NEARLIFE STATUS] is set to [DIS-ABLE].
- Do not expose the image drum unit to direct sunlight or strong light (approximately 1,500 lux or more). Do not leave the image drum unit exposed for 5 minutes or more, even under room lighting.



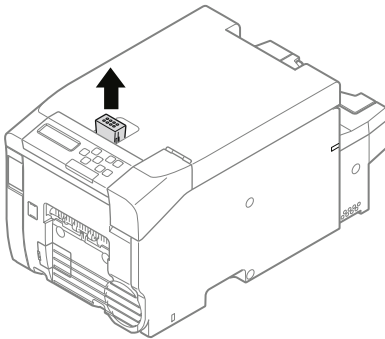

- You can change the timing for displaying the "ORDER FUSER UNIT" message. Set it using [ADMIN SETUP] > [OTHERS SETUP] > [NEARLIFE SETUP] > [FUSER NEARLIFE] on the operation panel. Available values are from 500 to 5,000 (in 500 increments).

Insert your finger into the recess on the top of the machine and pull up the lever.





- Open the top cover until it stops.

 CAUTION	Burns may result.	
The fuser unit is extremely hot. Do not touch it.		

- Hold the blue handle and pull out the image drum unit vertically.



- Pull it out after opening the top cover fully.
- Place the image drum unit you took out on a flat surface and cover it with black paper, etc. so that the image drums are not exposed to light.
- Pull up the blue handle at the front of the machine interior and pull out the fuser unit vertically.

 CAUTION	Burns may result.	
Since the fuser unit gets hot, carry out the operation carefully, and make sure to hold it by the handle when lifting it up. When it is hot, do not attempt to carry out the operations. Wait until it is cooled down and then carry out the operations.		

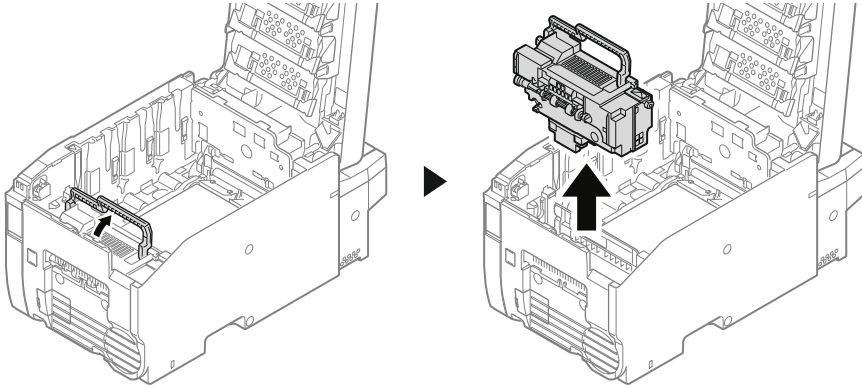

- Hold the blue handle of a new fuser unit, align the red ▲ on the right side and the red ▼ in the machine, and lower it vertically to set the unit in the machine.

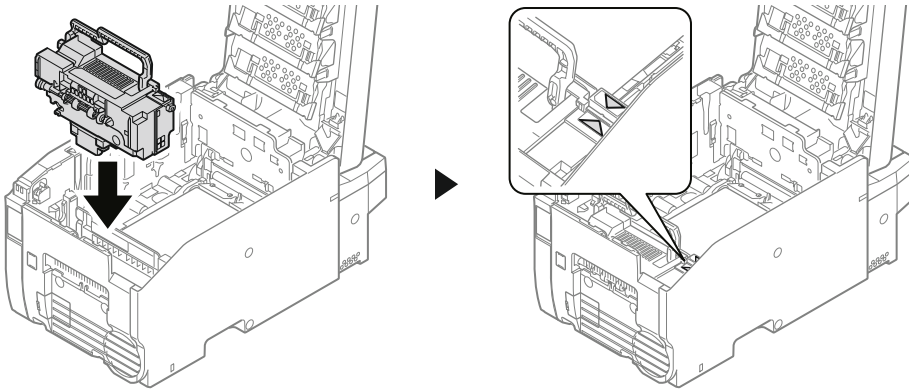

- Turn down the blue handle of the fuser unit toward you to put it away.

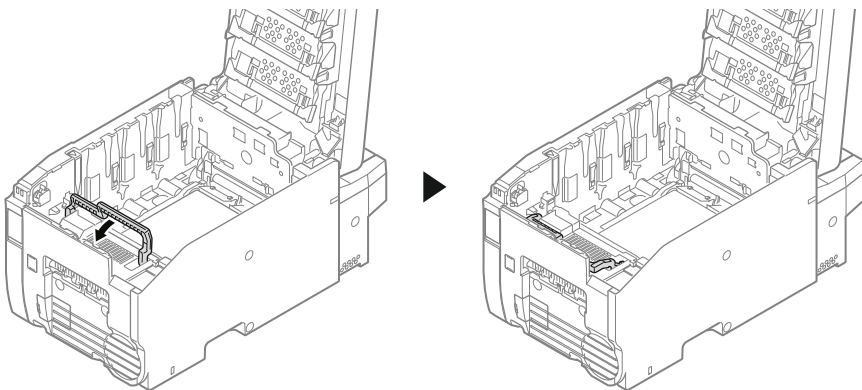

- Hold the blue handle of a image drum unit, confirm the position to install it to the machine, and lower it vertically.

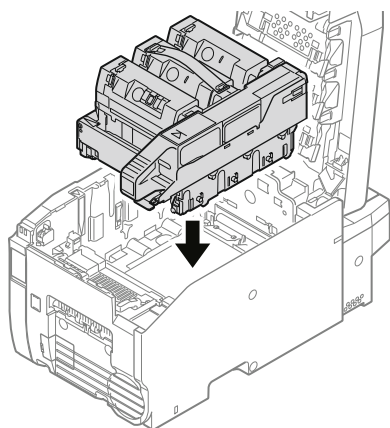

- Close the top cover.

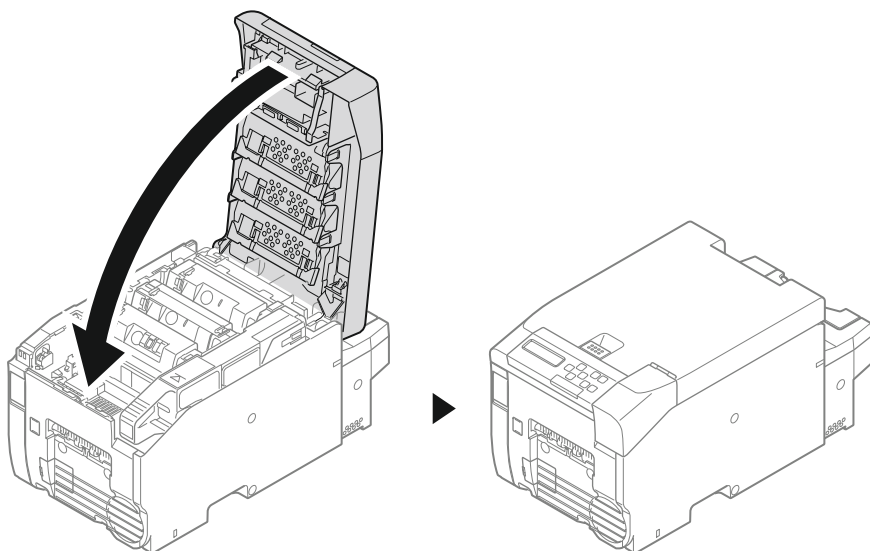

Replacing the Transfer Belt Unit

When "ORDER BELT UNIT" is displayed on the screen of the operation panel, prepare a replacement transfer belt unit. The estimated timing for the next message to be displayed is when printing approximately 5,000 pages.

When "BELT UNIT LIFE" is displayed, replace the transfer belt unit.

The estimated replacement cycle of the transfer belt unit is approximately 100,000 pages for 216 mm simplex printing (one page per job).

- The actual number of pages you can print with the transfer belt unit depends on how you use it.
- Even after "BELT UNIT LIFE" is displayed, you can extend the lifetime of the transfer belt unit somewhat by opening and closing the cover, etc., but we recommend you replace the transfer belt unit soon to prevent malfunction.
- Replace the transfer belt unit after you use it up to the end of its lifetime. If you use the removed transfer belt unit with another device, its lifetime will not be displayed correctly.



- "ORDER BELT UNIT" is not displayed when [ADMIN SETUP] > [PANEL SETUP] > [NEARLIFE STATUS] is set to [DISABLE] on the operation panel.
- Use extra care when handling the image drum (the glossy cylinder), because it is fragile.
- Do not expose the image drum unit to direct sunlight or strong light (approximately 1,500 lux or more). Do not leave the image drum unit exposed for 5 minutes or more, even under room lighting.



- You can change the timing for displaying the "ORDER BELT UNIT" message. Set it using [ADMIN SETUP] > [OTHERS SETUP] > [NEARLIFE SETUP] > [BELT NEARLIFE] on the operation panel. Available values are from 500 to 5,000 (in 500 increments).

Insert your finger into the recess on the top of the machine and pull up the lever.

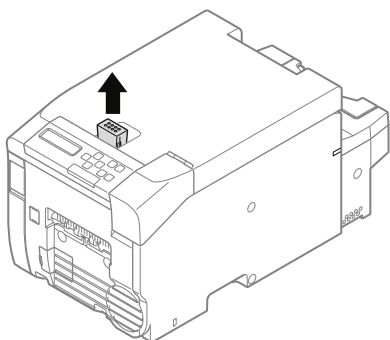

- Open the top cover until it stops.

CAUTION	Burns may result.	
The fuser unit is extremely hot. Do not touch it.		

- Hold the blue handle and pull out the image drum unit vertically.



- Pull it out after opening the top cover fully.
- Place the image drum unit you took out on a flat surface and cover it with black paper, etc. so that the image drums are not exposed to light.
- Hold the handle (black) of the transfer belt unit and pull it out vertically.

CAUTION	Burns may result.	
The fuser unit is extremely hot. Do not touch it.		

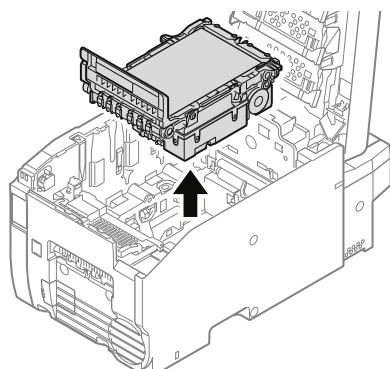

- Hold the handle (black) of a new transfer belt unit, and lower it vertically to set the unit into the machine.

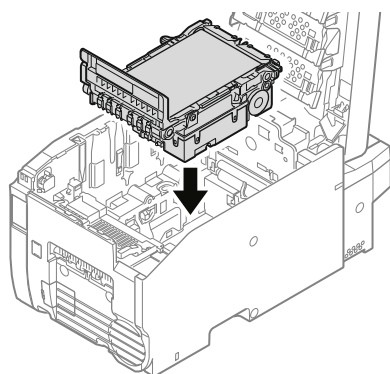

- Hold the blue handle of a image drum unit, confirm the position to install it to the machine, and lower it vertically.

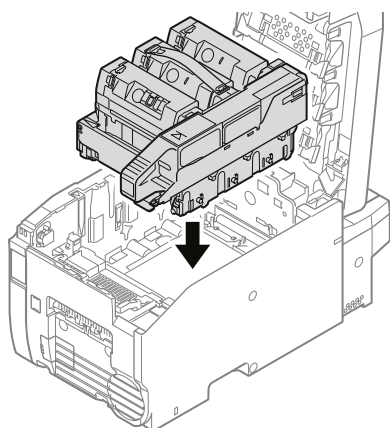

- Close the top cover.

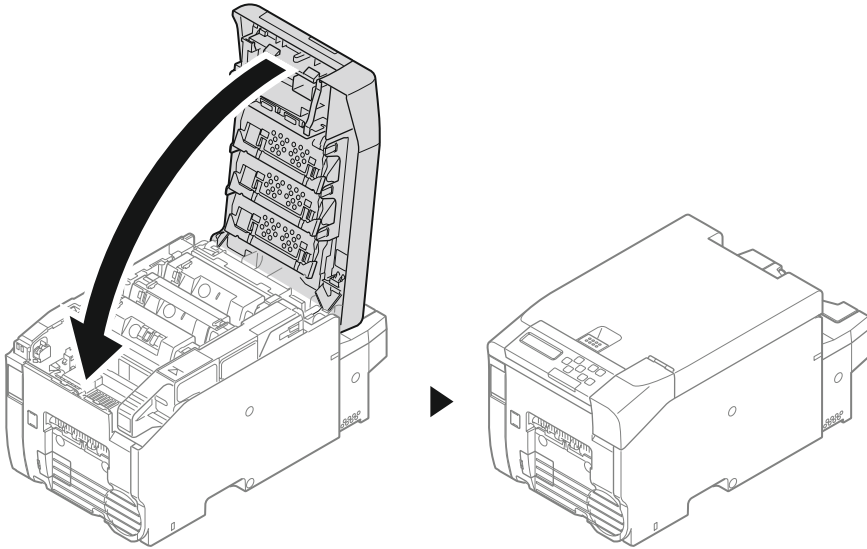

Replacing the Feed Roller

When paper jams frequently occur or the color is shifted, replace the feed roller.

The feed roller should be replaced after approximately 60 km of printing.

- The actual lifetime of a feed roller depends on environment and paper.
 - If paper jams persists even after cleaning the feed roller, we recommend that you replace the feed roller.
- Insert your finger into the recess on the top of the machine and pull up the lever.**

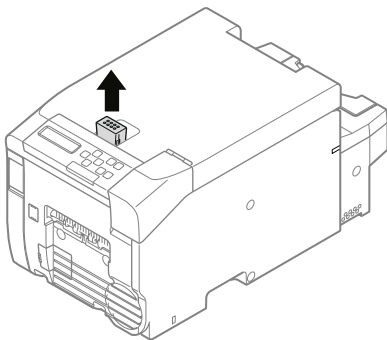

- Open the top cover until it stops.



CAUTION

Burns may result.



The fuser unit is extremely hot. Do not touch it.

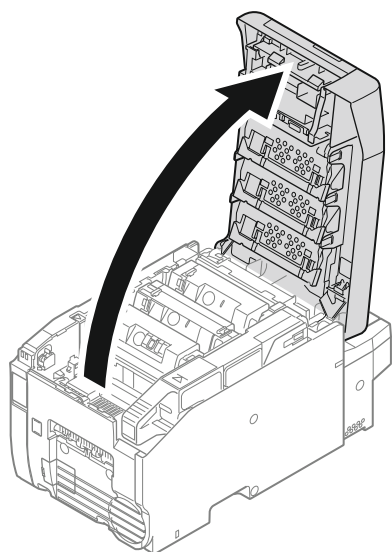

- Hold the blue handle and pull out the image drum unit vertically.



- Pull it out after opening the top cover fully.

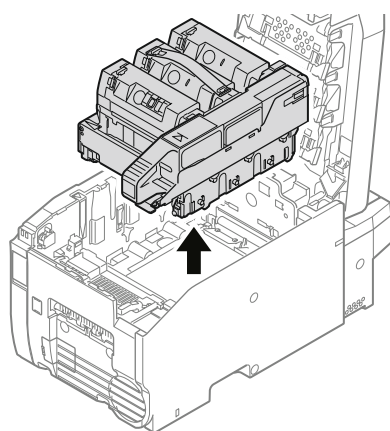

- Place the image drum unit you took out on a flat surface and cover it with black paper, etc. so that the image drums are not exposed to light.

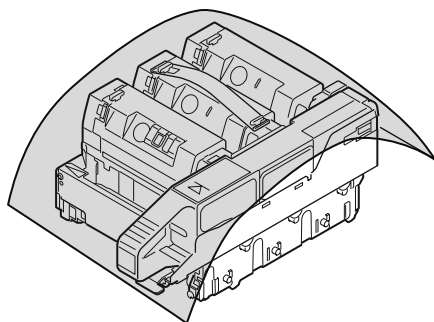

- Hold the handle (black) of the transfer belt unit and pull it out vertically.

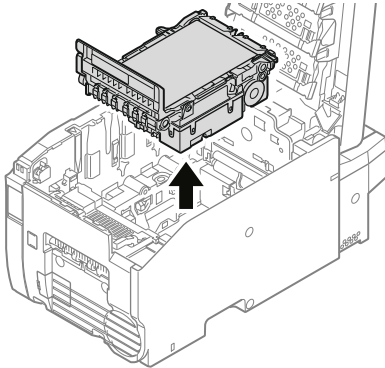

- Insert your fingers in the both ends of the recess in the center bottom of the back of the machine interior, and turn down the sensor lever towards yourself.

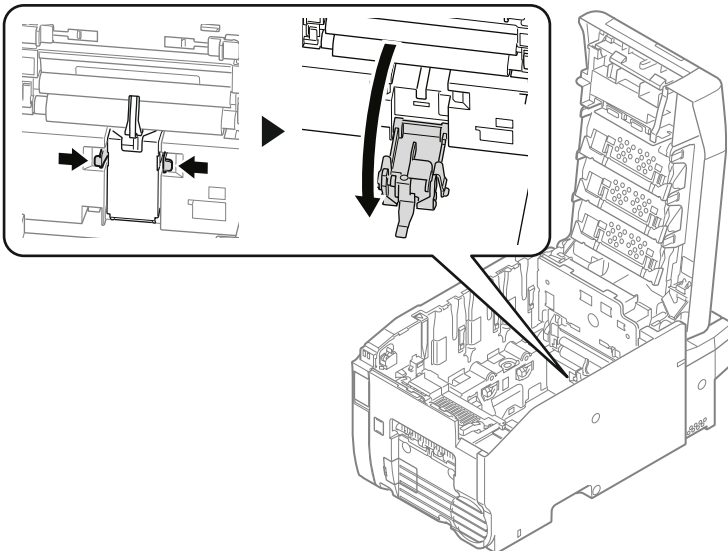

- Slide the blue levers (two locations) inside the machine inward to unlock it.
- Hold the tabs (white and black) on the right and left sides of the feed roller and pull it out.
- Attach a new feed roller into the machine.
 - ▶ Set it so that it is on the same surface as the blue lock.
- Slide the blue levers (two locations) outward to fix the feed roller.
 - ▶ Ensure that the blue lock is over the black knob on the right and that the blue lock is over the left knob.
- Push the sensor lever into the machine.
 - ▶ Return it to its original position.
- Return the transfer belt unit to its original position in the machine.
- Return the image drum unit to its original position in the machine.

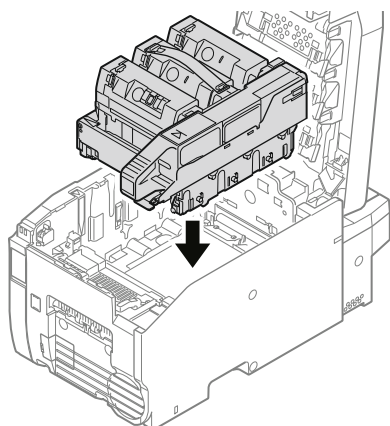

- Close the top cover.

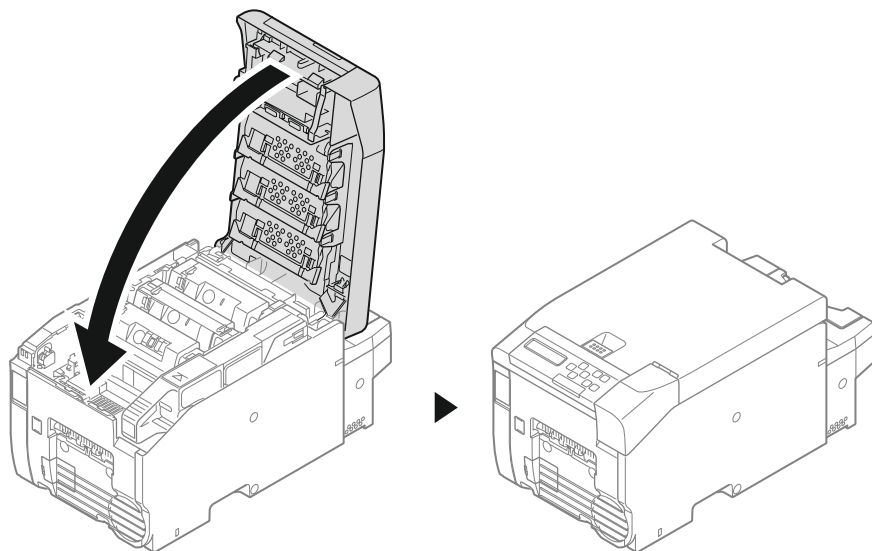

Replacing the Paper Feed Roller

When paper jams frequently occur, replace the paper feed roller. The paper feed roller should be replaced after approximately 60 km of printing.

Turn the machine to make its rear side face to you.

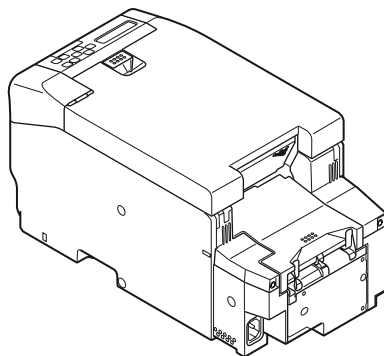

- Insert your finger below the gray lever on the left, and lift it up to open the feeder cover.



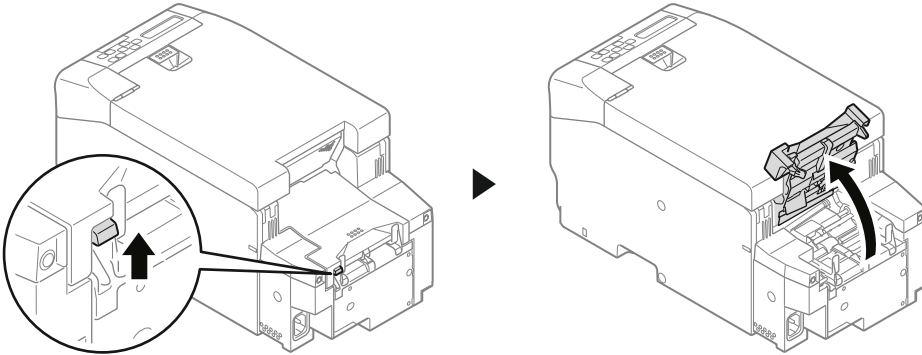

- Loosen the right screw with a driver.

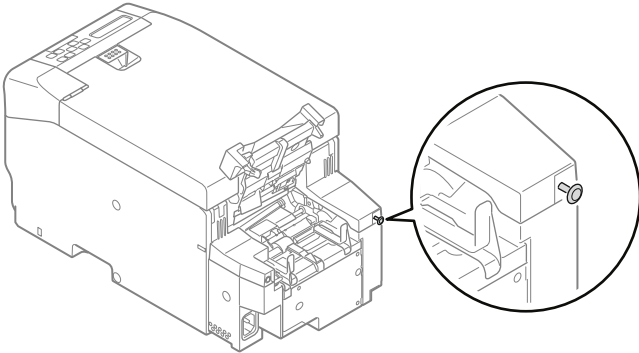

- Lift up the right-side side cover to remove it.

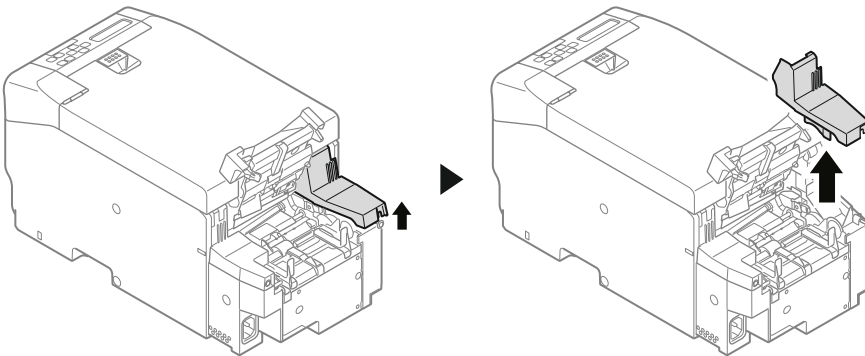

- Loosen the left screw with a driver.

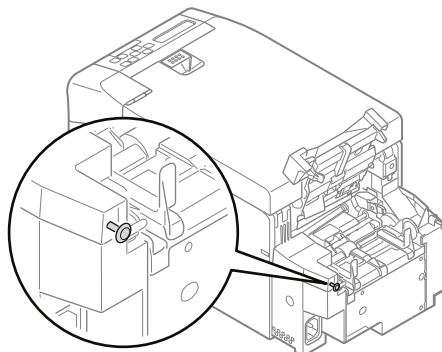

- Lift up the left-side side cover to remove it. Lift the front up and pull it out forwards.

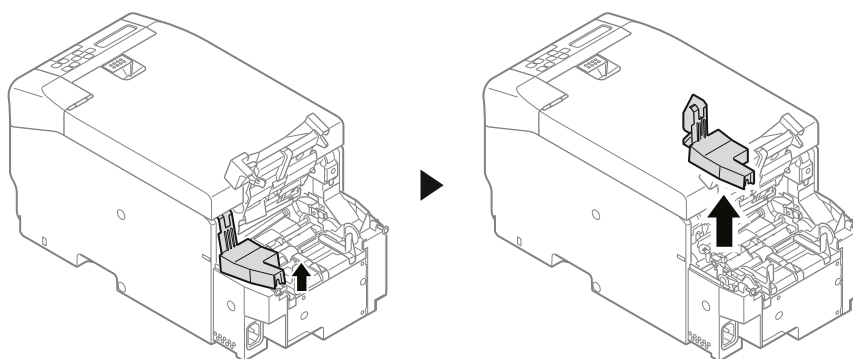

- Turn up the left lever of the paper feed roller to unlock it.

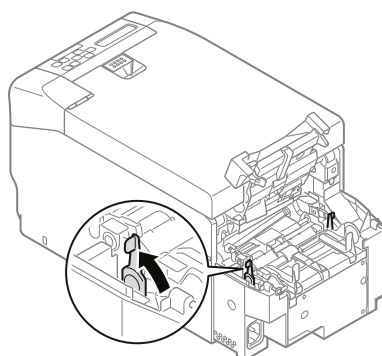

- Turn up the right lever of the paper feed roller to unlock it.

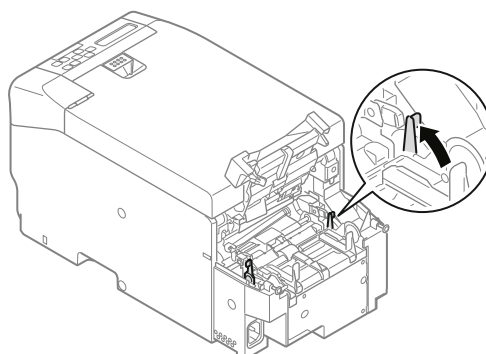

-
- Hold the right and left levers of the paper feed roller and lift it directly up.

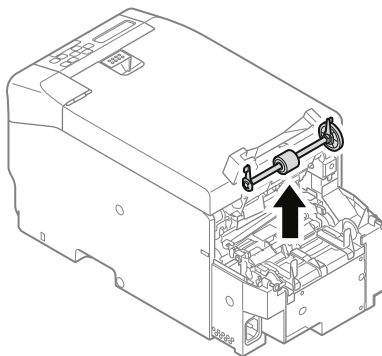

- Hold the right and left levers of a new paper feed roller and insert the roller vertically. With the side with the

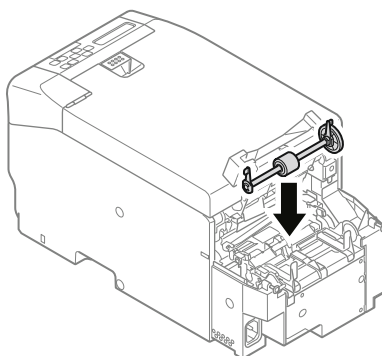

white gear on the right, hold the blue levers on both ends and insert it from directly above.

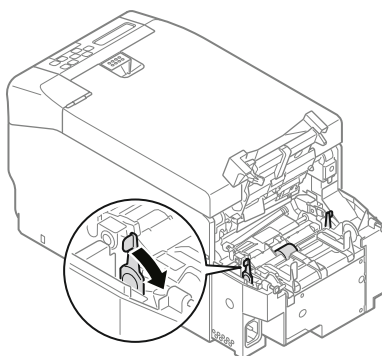

- Turn down the left lever of the paper feed roller until it stops to lock it.

- Turn down the right lever of the paper feed roller until it stops to lock it.

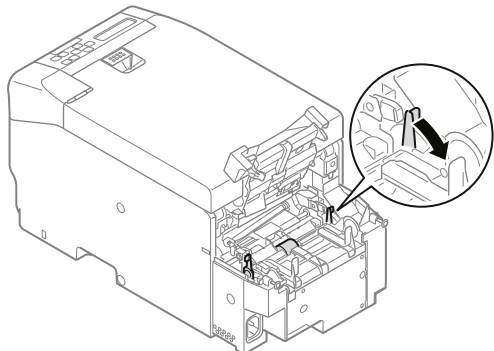

- Attach the left-side side cover over the top and tighten the screw.

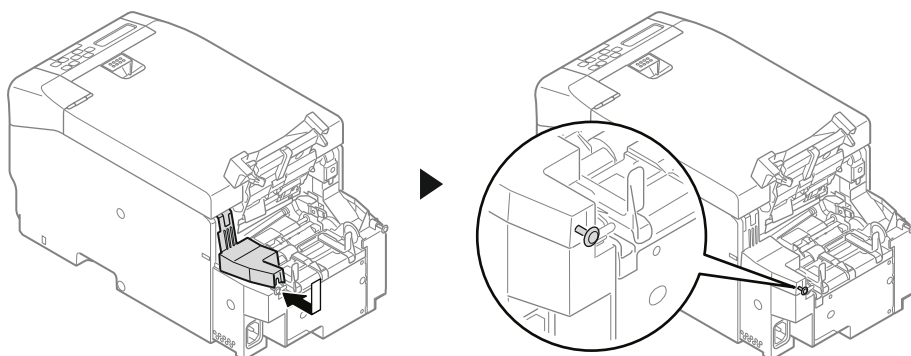

- Attach the right-side side cover over the top and tighten the screw.

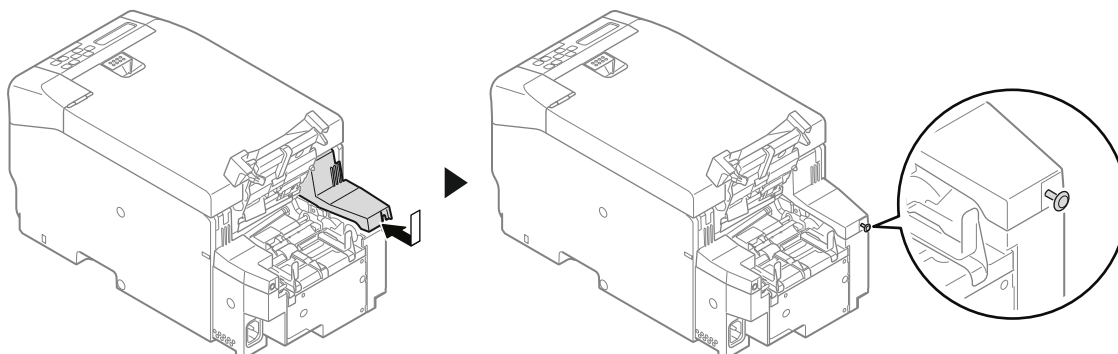

- Close the feeder cover until it clicks.

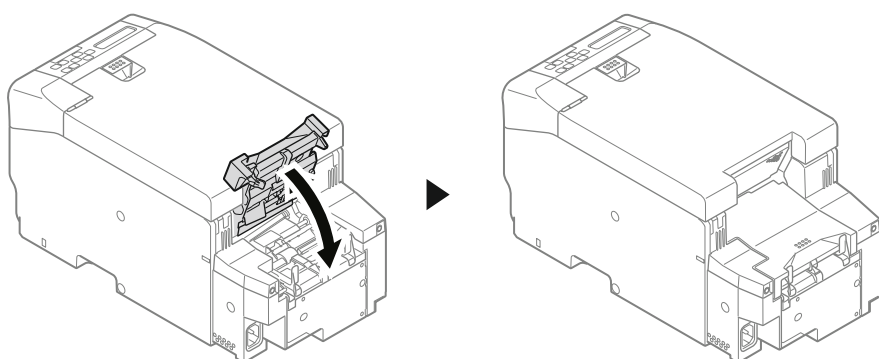

Cleaning the Machine

Cleaning the Surface of the Machine

- Turn off the machine.



For information on turning off the machine, refer to "Turning Off the Machine".

- Wipe the surface of the machine with a cloth that has been moistened with water or neutral detergent and squeezed well.

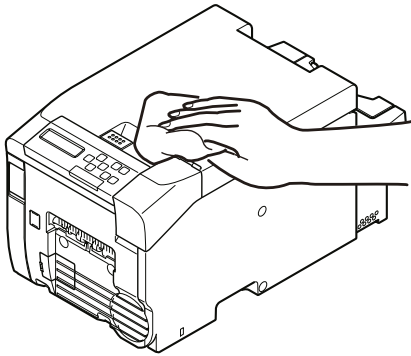

- Wipe the surface of the machine with a dry soft cloth.

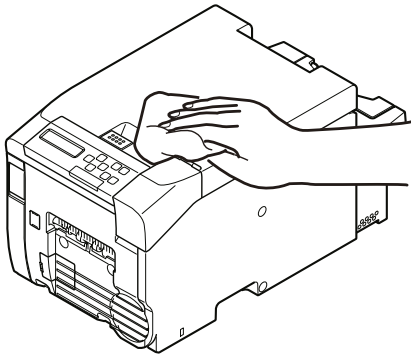

Cleaning the LED Head

Clean the LED head if white lines or black lines appear, images are faded, or the periphery of letters are smudged in the printouts.



- Do not use solvents, such as methyl alcohol or thinners. They may damage the LED head.
- Do not expose the image drum unit to direct sunlight or strong light (approximately 1,500 lux or more). When leaving the image drum unit under room lighting for five minutes or more or leaving the top cover open, cover it with a black cloth or paper to prevent it from being exposed to light.
- Insert your finger into the recess on the top of the machine and pull up the lever.

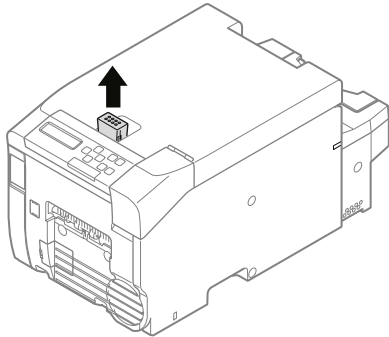

- Open the top cover until it stops.

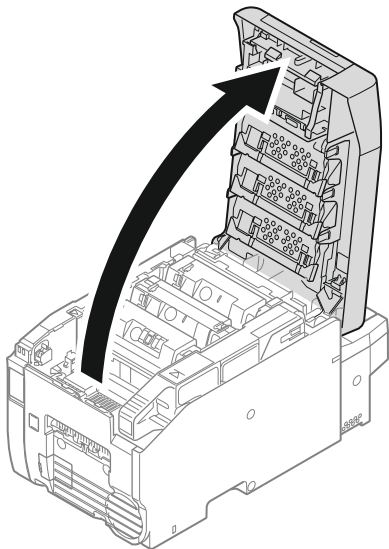

- Cover the image drum unit with black paper, etc. so that it is not exposed to light.

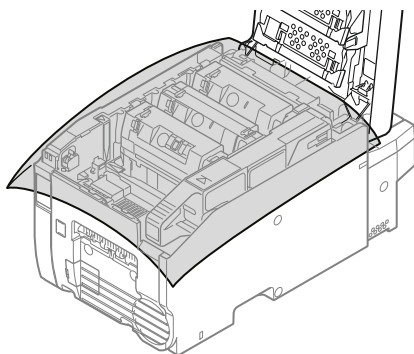

- Wipe the three lenses of the LED heads with a soft tissue lightly.

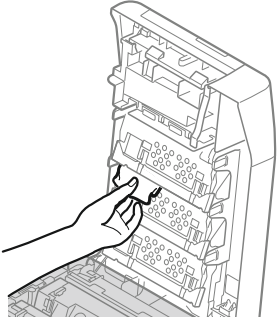

- Remove the black paper, etc. on the image drum unit, and close the top cover.

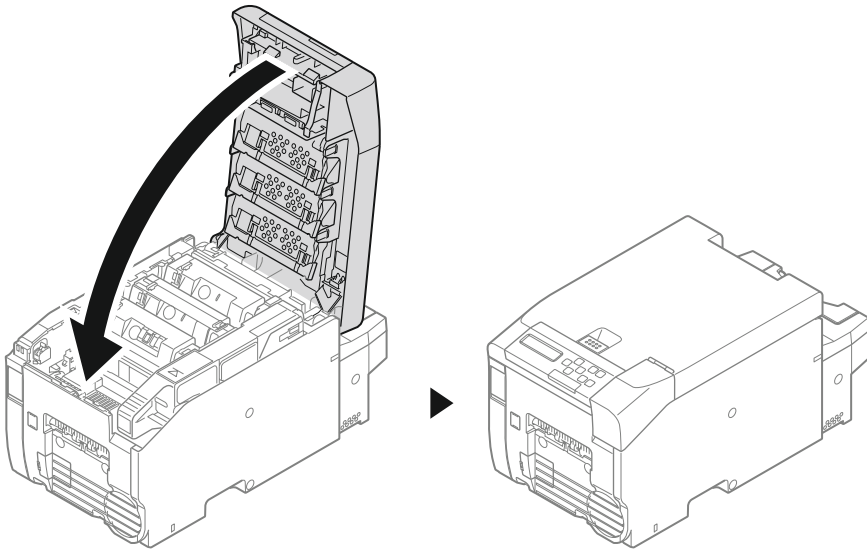

Cleaning the Feed Rollers

- Insert your finger into the recess on the top of the machine and pull up the lever.

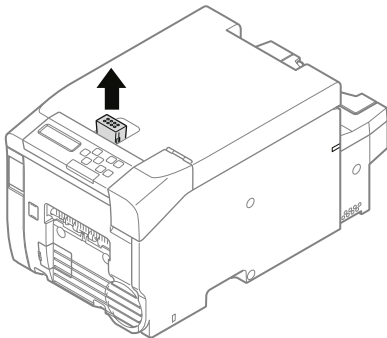

- Open the top cover until it stops.



CAUTION Burns may result.



The fuser unit is extremely hot. Do not touch it.

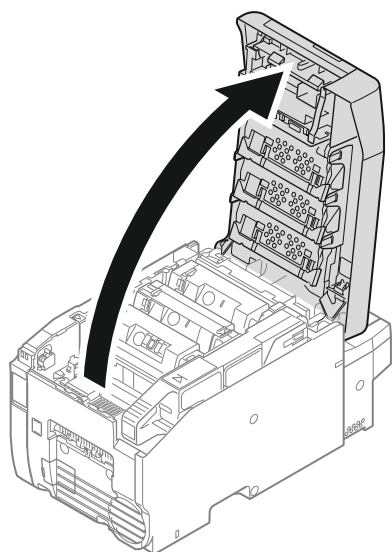

- Hold the blue handle and pull out the image drum unit vertically.

 Pull it out after opening the top cover fully.

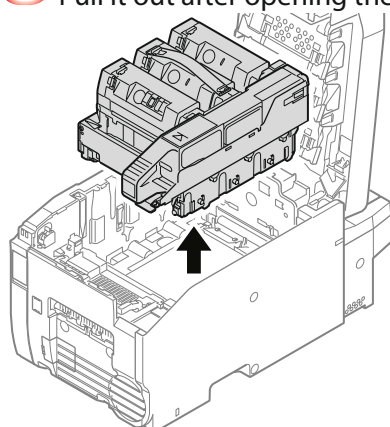

- Place the image drum unit you took out on a flat surface and cover it with black paper, etc. so that the image drums are not exposed to light.
- Hold the handle (black) of the transfer belt unit and pull it out vertically.
- Insert your fingers in the both ends of the recess in the center bottom of the back of the machine interior, and turn down the sensor lever towards yourself.
- Wipe the feed roller with a soft cloth that has been moistened with water and then squeezed well.

Cleaning the Paper Feed Rollers

- Turn the machine to make its rear side face to you.

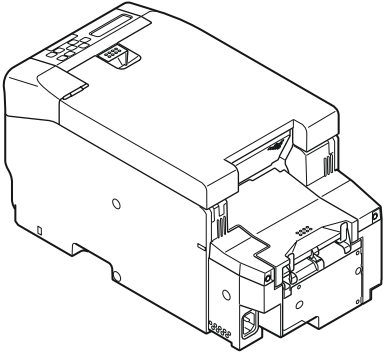

- Insert your finger below the gray lever on the left, and lift it up to open the feeder cover.

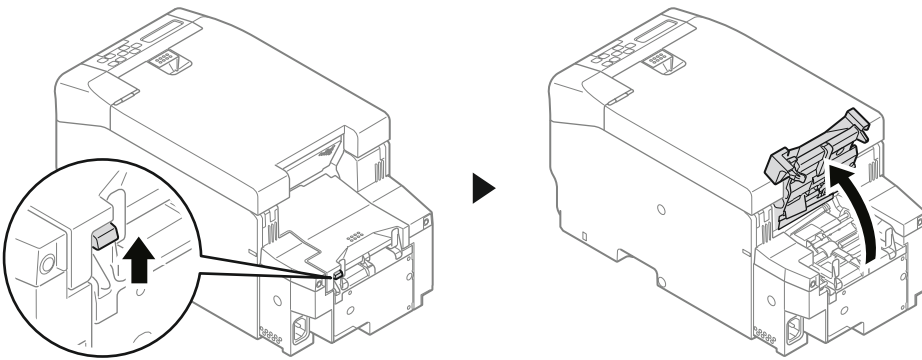

- Wipe the paper feed roller with a soft cloth that has been moistened with water and then squeezed well.

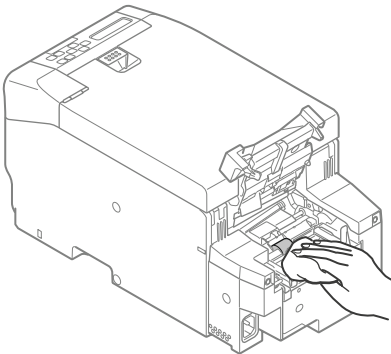

When the LED Lights Up

When a problem occurs in the machine, the ERROR LED or WARNING LED lights up or flashes and a message is displayed on the screen.

Check the message and perform the remedy.

For details, refer to "List of Messages".

When the Paper Is Jammed

Error 381/730-06 (Paper on the Transfer Belt Unit)

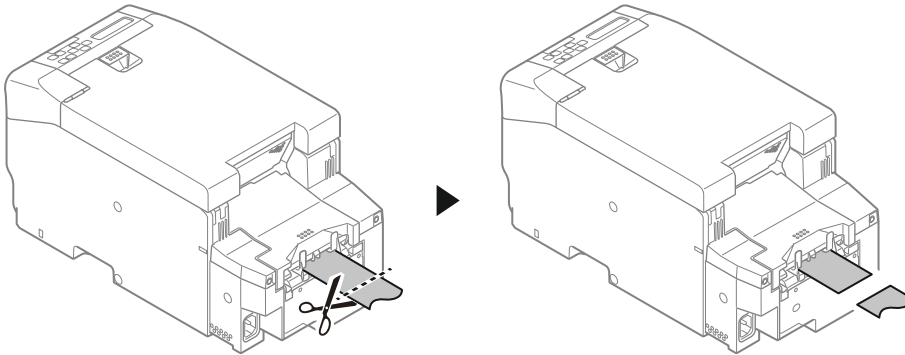

- If the paper is continuous, cut the paper with scissors near the paper inlet unit.

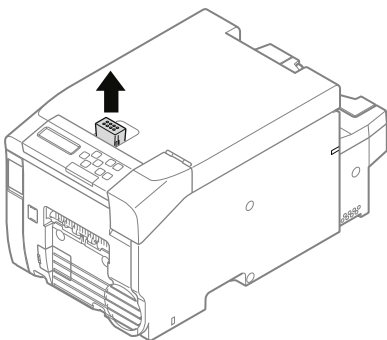

- Insert your finger into the recess on the top of the machine and pull up the lever.



- Open the top cover until it stops.

 CAUTION	Burns may result.	
The fuser unit is extremely hot. Do not touch it.		

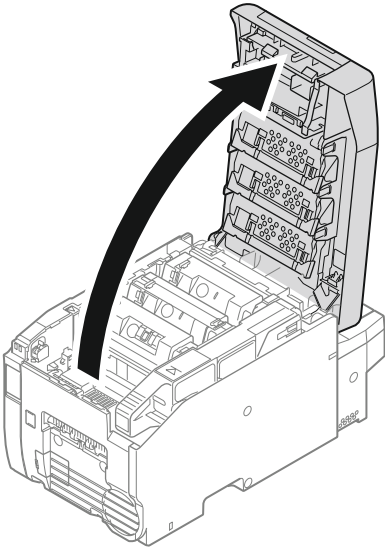

- Hold the blue handle and pull out the image drum unit vertically.



- Pull it out after opening the top cover fully.

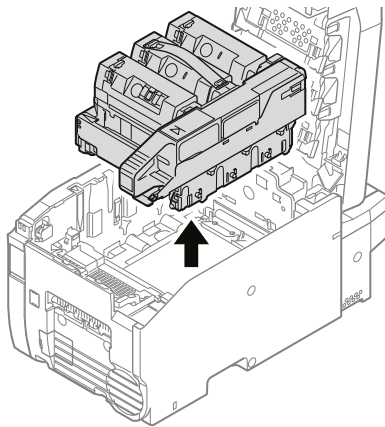

- Place the image drum unit you took out on a flat surface and cover it with black paper, etc. so that the image drums are not exposed to light.

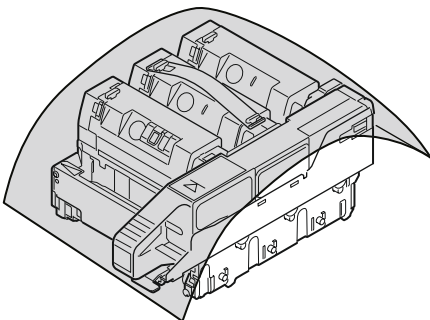

- If the tip of the paper is visible, gently pull it out to the front.

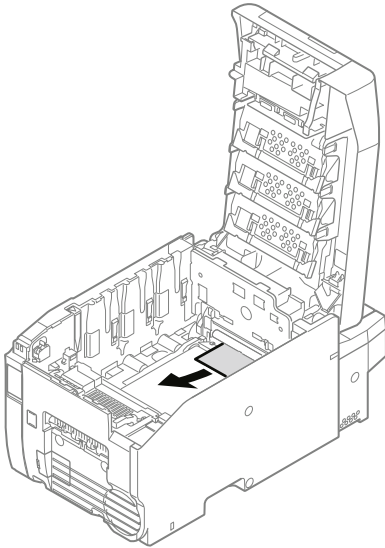

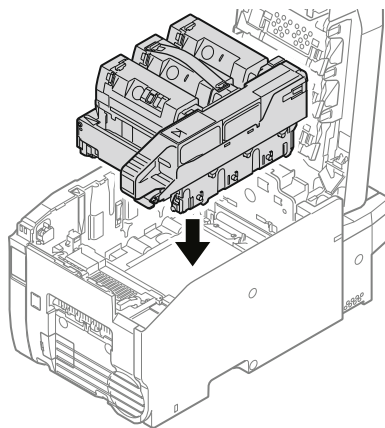

- If paper is jammed in the fuser unit, refer to "Error 382 (Paper Jammed in the Fuser Unit)".
- Return the image drum unit to its original position in the machine.



- Close the top cover.

Error 382 (Paper Jammed in the Fuser Unit)

- If the paper is continuous, cut the paper with scissors near the paper inlet unit.
- Insert your finger into the recess on the top of the machine and pull up the lever.
- Open the top cover until it stops.

 CAUTION	Burns may result.	
The fuser unit is extremely hot. Do not touch it.		

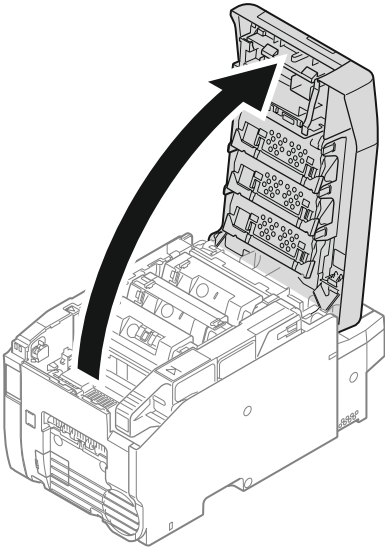

- Hold the blue handle and pull out the image drum unit vertically.



- Pull it out after opening the top cover fully.

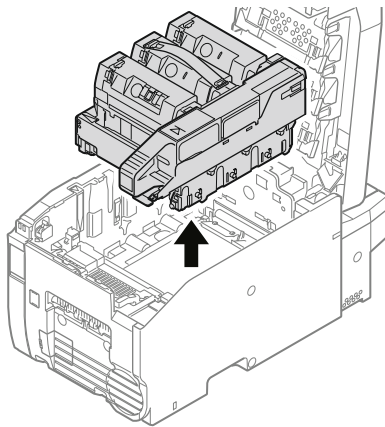

- Place the image drum unit you took out on a flat surface and cover it with black paper, etc. so that the image drums are not exposed to light.
- Take out the fuser unit.



CAUTION Burns may result.



Since the fuser unit gets hot, carry out the operation carefully, and make sure to hold it by the handle when lifting it up. When it is hot, do not attempt to carry out the operations. Wait until it is cooled down and then carry out the operations.

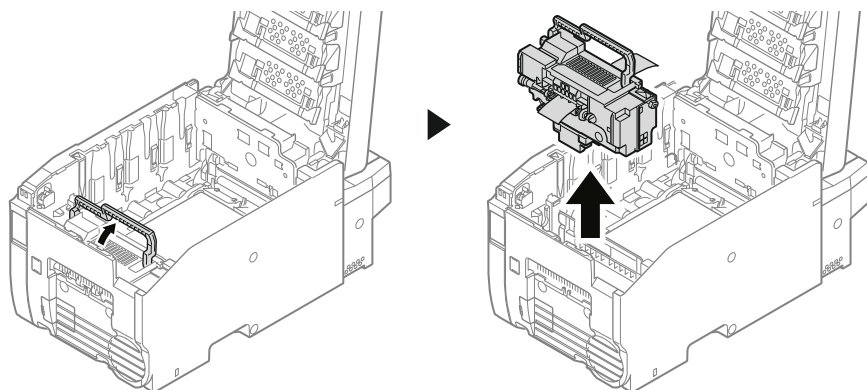

- Gently pull the paper out to the back of the fuser unit (the opposite direction from the paper feed direction).

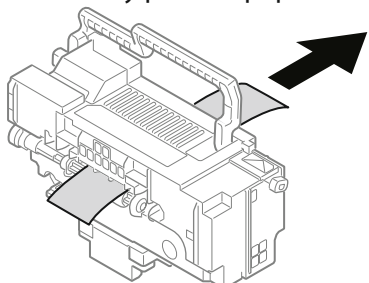

- Align the red ▲ on the right side of the fuser and the red ▼ in the machine, and lower it vertically, and return it to its original position in the machine.

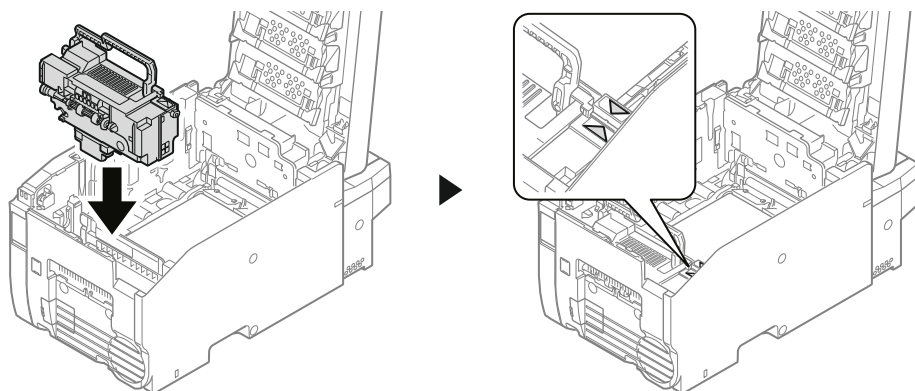

- Turn down the blue handle of the fuser unit toward you to put it away.

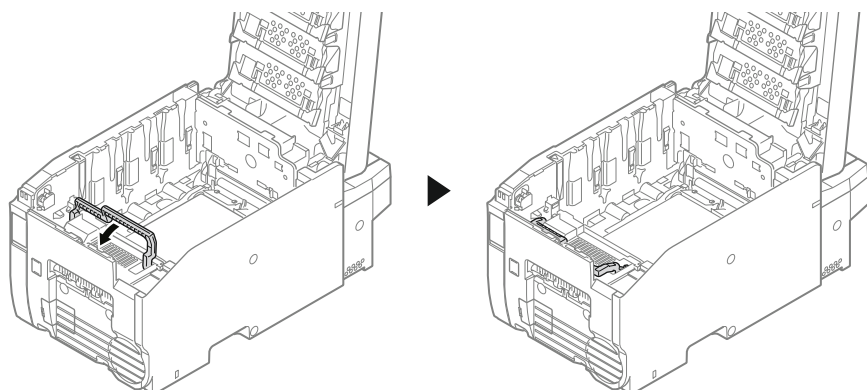

- Return the image drum unit to its original position in the machine.

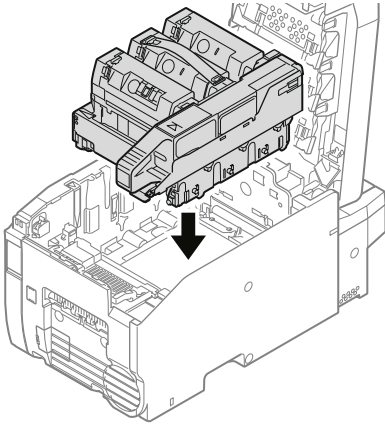

- Close the top cover.

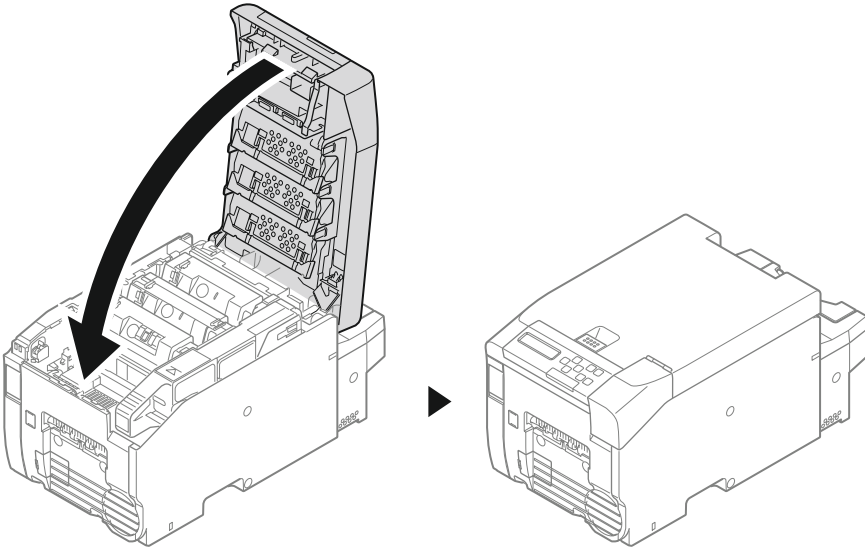

Error 380/390 (Paper Jammed Near the Cutter)

- Turn the machine to make its rear side face to you.

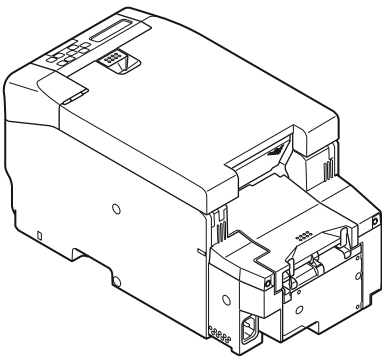

- Insert your finger below the gray lever on the left, and lift it up to open the feeder cover.

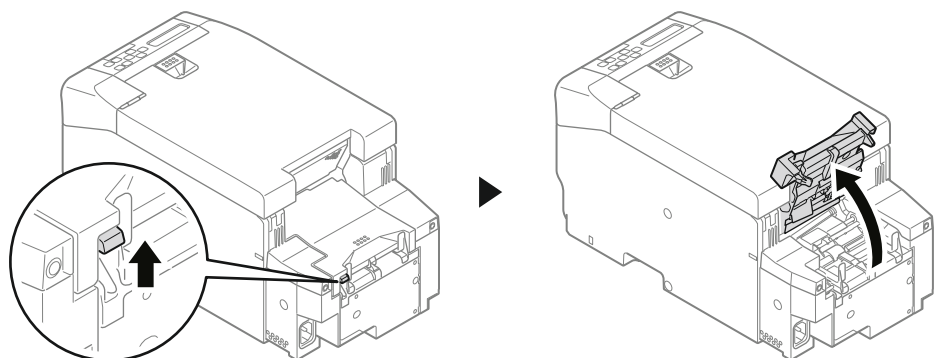

- Gently pull out the jammed paper.

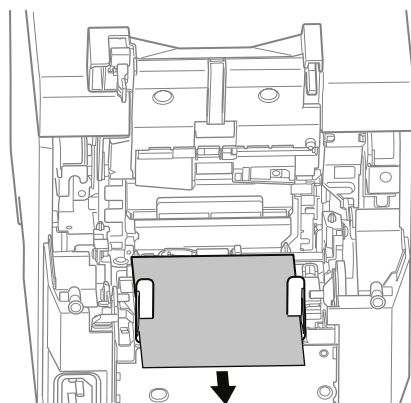

- Close the feeder cover until it clicks.

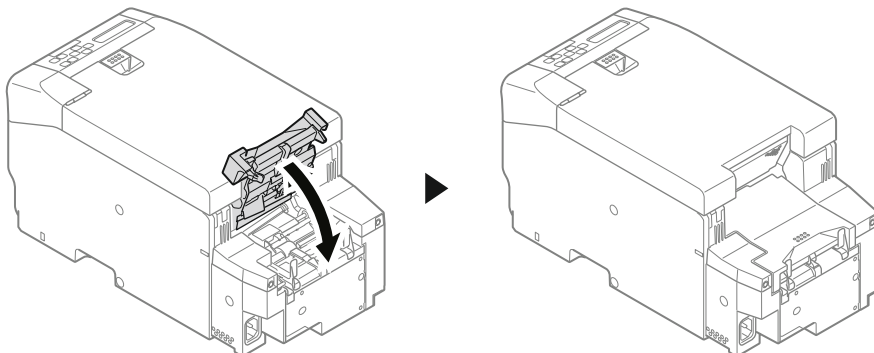

Canceling Printing

Pressing «CANCEL» Button

- Press «CANCEL» button on the operation panel to cancel printing.

Canceling from a Computer

You can cancel printing from a computer when a large amount of data has been accidentally sent to the printer.

- Click [Devices and Printers].
- Right-click the icon for the printer, and select [See print jobs].
- Select the file name to cancel printing for.
- Press the <Delete> key on the keyboard.
- Check the display of the control panel.
- Printing can be canceled from the operation panel of the machine when "PROCESSING" or "DATA" is displayed.

Cannot Print

Cause	Remedy	Reference
The machine is in the Sleep mode.	Press «POWER SAVE» button on the operation panel to switch the machine to standby.	Using the Operation Panel
This machine is not turned on.	Turn the machine on.	Turning On the Machine
<ul style="list-style-type: none"> • The LAN cable/USB cable is disconnected. 	<ul style="list-style-type: none"> • Check whether the cable is correctly connected to the computer and the machine. 	<ul style="list-style-type: none"> • Using the Machine
<ul style="list-style-type: none"> • There is a problem with the cable. 	<ul style="list-style-type: none"> • Replace the cable with a new one. 	<ul style="list-style-type: none"> • -

Cause	Remedy	Reference
<ul style="list-style-type: none"> The machine is offline. 	<ul style="list-style-type: none"> Press «ONLINE» button on the operation panel to display [READY TO PRINT]. 	<ul style="list-style-type: none"> -
<ul style="list-style-type: none"> An error message is displayed on the screen of the operation panel. 	<ul style="list-style-type: none"> Check the displayed error message and perform the remedy. 	<ul style="list-style-type: none"> List of Messages
<ul style="list-style-type: none"> The interface settings are disabled. 	<ul style="list-style-type: none"> Check the interface settings to see whether the machine settings match the connection environment. 	<ul style="list-style-type: none"> Using the Machine Connecting via Wireless LAN
<ul style="list-style-type: none"> There is a problem with the print function. 	<ul style="list-style-type: none"> Check whether the configuration list can be printed. 	<ul style="list-style-type: none"> Checking Information about the Machine
<ul style="list-style-type: none"> The machine is not set as the default printer. 	<ul style="list-style-type: none"> Set the machine as the default printer. Right-click the [Your Printer] icon in the [Devices and Printers] folder, and select [Set as default printer]. 	<ul style="list-style-type: none"> -
<ul style="list-style-type: none"> The output port of the printer driver is incorrect. 	<ul style="list-style-type: none"> Select the output port where the LAN cable/USB cable is connected. 	<ul style="list-style-type: none"> -
<ul style="list-style-type: none"> Printing is being processed from another interface. 	<ul style="list-style-type: none"> Wait until the process is complete. 	<ul style="list-style-type: none"> -
<ul style="list-style-type: none"> [PRESS OK BUTTON/INVALID DATA] is displayed on the screen of the operation panel and printing is not performed. 	<ul style="list-style-type: none"> Set a longer time in [MENUS] > [SYSTEM ADJUST] > [TIMEOUT INJOB] on the operation panel. The default setting is 40 seconds. When [PRESS OK BUTTON/INVALID DATA] is displayed on the screen of the operation panel and printing is not performed, the print data may not be suitable for the machine. Check whether the printer driver matches the machine. 	<ul style="list-style-type: none"> -

List of Messages

This section describes the messages displayed on the operation panel.

- : Means that an arbitrary message is displayed on the top.
- [CODE] : Displays an arbitrary numeric value.
- [INFO] : Displays an arbitrary message.
- [FS_ERROR] : Displays an arbitrary numeric value.
- [ERRERROR] : Displays an arbitrary numeric value.
- [SUBCODE] : Displays an arbitrary numeric value.
- [COVER] : Indicates the top cover or feeder cover.

Message	Description
PLEASE WAIT	Wait until the machine becomes ready to print.
INITIALIZING	The machine is initializing. Wait until the machine becomes ready to print.

Message	Description
MENU RESETTING	The menu items are being reset. Wait until the machine becomes ready to print.
WAIT A MOMENT NETWORK INITIAL	The network settings are being initialized. Wait until the machine becomes ready to print.
DETECTED AN ABNORMALITY OF INTERNAL DATABASE AFTER PRESSING [OK] THE DATA WILL BE DELETED AND THEN REBOOT	An error occurred in the internal database of the machine. Press «OK» button to delete the data. The machine then restarts.
PU FLASH ERROR	The machine cannot start. Contact your dealer.
READY TO PRINT	Printing can be performed.
OFFLINE	The machine is offline. Press «ONLINE» button to turn the machine online.
FILE ACCESSING	The internal file system of the machine is being accessed. Wait until the machine becomes ready to print.
DATA ARRIVE	Data is being received.
PROCESSING	Data is being processed.
DATA	Unprinted data remains in the machine.
PRINTING	The machine is printing.
PRINT DEMO PAGE	A demonstration page is being printed.
PRINT CONFIGURATION	The settings of the machine are being printed.
PRINT FILE LIST	The list of files stored in the internal file system of the machine is being printed.
PRINT ERROR LOG	An error log is being printed.
<input type="checkbox"/> COPY kkk/lll	A copy is being printed. [kkk] indicates the number of pages being printed and [lll] indicates the total number of pages.
CANCELING JOB	Printing is being canceled.
CANCELING JOB (JAM)	The print data is being deleted because a paper jam occurred.
<input type="checkbox"/> ADJUSTING TEMP.	The temperature of the fuser unit is being adjusted.
<input type="checkbox"/> OPTIMIZING TEMP	The internal temperature of the machine is being adjusted.
<input type="checkbox"/> POWER SAVE	The machine is in the Power Save mode.
<input type="checkbox"/> SLEEP MODE	The machine is in the Sleep mode.
CHANGING LANGUAGE PLEASE WAIT	The language displayed on the operation panel is being changed. Wait until the machine becomes ready to print.
LANGUAGE CHANGE FAILED ERROR NUM: [CODE]	Failed to change the language displayed on the operation panel. Turn the machine off and then on again.
<input type="checkbox"/> ADJUSTING COLOR	Automatic color shift correction is being performed.
<input type="checkbox"/> ADJUSTING DENSITY	Automatic density correction is being performed.
PLEASE WAIT EXECUTING MAINTENANCE	The machine is executing maintenance. Wait until the machine becomes ready to print.

Message	Description
FEEDING	Paper is being fed.
<input type="checkbox"/> USB MEMORY CONNECTING	USB memory is connecting to the machine.
PLEASE LOAD PAPER SENSOR CALIBRATING	The paper sensors are being adjusted.
<input type="checkbox"/> TAKE LABEL	Paper is waiting to be pulled out from the machine. Pull out the paper.
<input type="checkbox"/> ORDER TONER	Toner is low. Prepare a new toner cartridge.
<input type="checkbox"/> TONER NOT RECOMMENDED	The toner cartridge is not recommended for the machine.
PRESS OK BUTTON ERROR PDL	An error has occurred in the machine. Press «OK» button to clear the error.
<input type="checkbox"/> ORDER IMAGE DRUM	The image drum unit is reaching the end of its lifetime. Prepare a new image drum unit.
<input type="checkbox"/> ORDER FUSER UNIT	The fuser unit is reaching the end of its lifetime. Prepare a new fuser unit.
<input type="checkbox"/> ORDER BELT UNIT	The transfer belt unit is reaching the end of its lifetime. Prepare a new transfer belt unit.
<input type="checkbox"/> FUSER UNIT LIFE	The fuser unit has reached the end of its lifetime, and printing will stop soon. Prepare a new fuser unit.
<input type="checkbox"/> BELT UNIT LIFE	The transfer belt unit has reached the end of its lifetime, and printing will stop soon. Prepare a new transfer belt unit.
<input type="checkbox"/> TONER EMPTY	The toner cartridge is empty, and printing will stop soon. Prepare a new toner cartridge.
<input type="checkbox"/> REPLACE TONER	The toner cartridge is empty. Replace the toner cartridge with a new one.
<input type="checkbox"/> TONER NOT INSTALLED	A toner cartridge is not installed in the machine. Set the toner cartridge in the machine.
<input type="checkbox"/> IMAGE DRUM NOT RECOMMENDED	A suitable image drum unit is not installed in the machine.
<input type="checkbox"/> IMAGE DRUM LIFE	The image drum unit has reached the end of its lifetime, and printing will stop soon. Prepare a new image drum unit.
<input type="checkbox"/> FILE SYSTEM IS FULL	The internal file system of the machine is full.
<input type="checkbox"/> FILE IS WRITE PROTECTED	The machine is trying to write to a file in the internal file system of the machine that does not allow writing.
PLEASE DETACH IT USB HUB UNSUPPORTED	The machine is connected to an unsupported USB hub. Remove the hub.
PLEASE DETACH IT UNSUPPORTED USB DEVICE DETECTED	The machine is connected to an unsupported USB device. Remove the USB device.
PLEASE DETACH IT UNRECOGNIZED USB DEVICE	The USB device connected to the device was not recognized correctly. Remove the USB device.
<input type="checkbox"/> SNTP SERVER COMMUNICATION ERROR	Failed to retrieve the time from the SNTP server. Check the network settings.
<input type="checkbox"/> FILE OPERATION FAILED [FS_ERR]	An error occurred in the internal file system of the machine. Operations that do not use the file system can be performed. The error is cleared when the following print data is received.





Message	Description
PRESS OK BUTTON INVALID DATA	Invalid data was received. Press «OK» button to clear the error.
CHANGE IPV4 ADDRESS IPV4 ADDRESS IS CONFLICTED	The IPv4 address is the same as another device. Check the IPv4 address.
PAPER DETECTION ERROR [ERRCODE]:ERROR [SUBCODE]	The paper sensor could not detect the paper correctly. Check the position, cleanliness, and settings of the paper sensor. The meaning of [SUBCODE] is indicated below. 0 to 6: An error has occurred in the bottom sensor. 11 to 15: An error has occurred in the top sensor. 21 to 26: An error has occurred in the translucent sensor.
CHANGE [MEDIA_SIZE] [MEDIA_TYPE] PRESS OK BUTTON	The paper type of the paper loaded in the machine does not match the print data. Load the correct paper to the machine. Press «OK» button when loading of the paper is complete.
RESTART PRINT? OK OR FEED/CUT	Press «OK» button to resume printing immediately. Press «FEED/CUT» button to resume printing after cutting the paper at the proscribed position. Press «CANCEL» button to return to the standby screen without printing.
REDUCE PRINT DATA [ERRCODE]:MEMORY OVERFLOW	The print data is too complex. Attach extra memory or reduce the size of the print data. This error is automatically cleared after approximately 15 seconds.
PRESS OK BUTTON [ERRCODE]:WIRELESS STARTUP ERROR	The wireless LAN module is not correctly connected to the machine. Correctly connect the wireless LAN module to the machine or turn the machine off and then on again. Press «OK» button to clear this message.
PRESS OK BUTTON [ERRCODE]:WIRELESS SETTINGS ARE INCOMPLETE	The wireless LAN settings are insufficient. Press «OK» button to clear this message.
PRESS OK BUTTON [ERRCODE]:NOT CONNECTED TO WIRELESS ACCESS POINT	The machine is not connected to the wireless access point. Press «OK» button to clear this message.
NETWORK CONFIG WRITING	Network related settings are being configured.
WAIT A MOMENT NETWORK INITIAL	Network related settings are being initialized.
DOWNLOAD MESSAGE PROCESSING	Message data for updating is being processed.
DOWNLOAD MESSAGE WRITING	Message data for updating is being written.
DOWNLOAD MESSAGE SUCCESS	Writing of message data for updating succeeded. The machine then restarts.
DOWNLOAD MESSAGE FAILED[ERRCODE]	Writing of message data for updating failed.
PRESS OK BUTTON FOR RESTORATION [ERRCODE]:RECEIVING DATA TIMEOUT	A timeout has occurred while receiving data. This error is automatically cleared after approximately 15 seconds.
PLEASE TRY AGAIN [ERRCODE]:FW UPDATE ERROR.IF NETWORK DOESN'T WORK,PLEASE TRY FW UPDATE OVER USB	Failed to update the firmware. Execute the firmware update again.
LOAD [MEDIA_SIZE] 490 :FEEDER EMPTY	The paper has run out. Load paper to the machine.

Message	Description
REPLACE TONER 412:TONER EMPTY	The toner has run out. Replace the toner cartridge with a new one.
TONER NOT RECOMMENDED 556:ERROR	Replace the toner cartridge with a recommended one.
INSTALL TONER [ERRCODE]:TONER MISSING	A toner cartridge is not installed in the machine. Set the toner cartridge in the machine.
IMAGE DRUM NOT RECOMMENDED 692, 702, 706, 686:ERROR	Replace the image drum unit with a recommended one.
UNKNOWN CONSUMABLEGO TO USER MANUAL "TROUBLE SHOOTING" 709	<p>You can use any consumables in your product, but you must accept the risks of using non-genuine consumables.</p> <p>If the use of non-genuine consumables causes damage to the product or results in your product not functioning to its full specification, then such damage or effect on the product is not covered by warranty.</p> <p>To accept these risks and to restore function;</p> <p>(1)Turn off your product.</p> <p>(2)Press and hold the «CANCEL» button and turn your product on.</p> <p>(3)After start up, release the «CANCEL» button.</p> <p>Note: This operation will be recorded for future reference.</p>
OPEN TOP COVER [ERRCODE]:PAPER SIZE ERROR	Paper of an inappropriate size has been fed. Check whether the loaded paper size is correct or whether multiple sheets of paper have been fed. Then open and close the top cover.
CHECK FEEDER 390:PAPER JAM	A paper jam occurred while supplying paper. Remove the paper jam. Or the cut type setting and paper sensor position of the machine do not match. Change the position of the top sensor and bottom sensor so that they do not overlap if their positions were matching. Change the position of the top sensor and bottom sensor so that they match if they were not overlapping.
OPEN TOP COVER [ERRCODE]:PAPER JAM	<p>A paper jam occurred while feeding paper. Remove the paper jam.</p> <p>ERRCODE 380 : Feed</p> <p>ERRCODE 381 : Transport</p> <p>ERRCODE 382 : Exit</p> <p>ERRCODE 389 : Printing Page Lost</p>
CHECK CUTTER UNIT 730-02:ERROR	An error has occurred in the cutter unit. Check the cutter unit.
MARK NOT FOUND 730-06:ERROR	<p>The paper mark could not be found. Check the position of the paper sensor.</p> <p>If an error occurs even if the sensor position is aligned, calibrate it.</p> <p> Adjusting the Paper Sensors (Sensor Calibration)</p>
REPLACE IMAGE DRUM [ERRCODE]:IMAGE DRUM LIFE	The image drum unit has reached the end of its lifetime. Replace the image drum unit with a new one.
REPLACE FUSER UNIT [ERRCODE]:FUSER UNIT LIFE	The fuser unit has reached the end of its lifetime. Replace the fuser unit with a new one.
REPLACE BELT UNIT [ERRCODE]:BELT UNIT LIFE	The transfer belt unit has reached the end of its lifetime. Replace the transfer belt unit with a new one.

Message	Description
CHECK IMAGE DRUM AND TONER CARTRIDGE 546:TONER CARTRIDGE MISSING	An error has occurred in the toner cartridge. Remove the toner cartridge, and set it again.
IMAGE DRUM MISSING 342:ERROR	The image drum unit is not set correctly. Set the image drum unit again.
CHECK FUSER UNIT [ERRCODE]:FUSER UNIT MISSING	The fuser unit is not set correctly. Set the fuser unit again.
CLOSE [COVER] [ERRCODE]:[COVER] OPEN	The displayed cover is open. Close the cover. ERRCODE 310: Top cover ERRCODE 589: Feeder cover
CLOSE TONER REPLACEMENT COVER 586:TONER COVER OPEN	The toner replacement cover is open. Close the toner replacement cover.
WAIT A MOMENT REBOOTING [%CODE%]	The machine is restarting. Wait until the machine restarts.
SHUTTING DOWN. PLEASE WAIT TURN OFF AUTOMATICALLY	The machine is shutting down. Wait until the power turns off.
TURN OFF POWER SHUTDOWN COMPLETED	The shutdown process of the machine is complete. Turn the machine off.
POWER OFF/ON [ERRCODE]:ERROR	A critical error has occurred in the machine. Turn the machine off and then on again. If the machine does not recover, contact your dealer.

Connection Problems

Network Connection Problems

Cause	Remedy	Reference
A cross cable is being used.	A cross cable is being used. Use a straight cable.	-
The machine was turned on before connecting the cable.	Turn the machine on after connecting the cable.	 Connecting a LAN Cable
There is a compatibility problem with the hub.	Select the correct connection in [ADMIN MENU] > [NETWORK SETUP] > [HUB LINK SETTING] of the menu.	-
The network connection settings are not suitable.	To connect to a wired network, set [WIRED] to [Enabled] for the network connection.	 Connecting a LAN Cable  Using Both a Wired LAN and Wireless LAN Connection
The IP addresses are incorrect.	Check whether the IP address of the machine matches the IP address of the machine set in the computer. Check whether the IP address is the same as another device. Check whether the IP address, subnet mask, and gateway address are correct.	 Checking Information About the Machine

Cause	Remedy	Reference
The WSD port is being used.	Change the destination port for printing to the standard TCP/IP port.	-

Wireless LAN Connection Problems

Cause	Remedy	Reference
The wireless LAN module is not enabled.	Set [WIRELESS MODULE] in [BOOT MENU] to [ENABLE].	Menu List
The network connection settings are not suitable.	<p>[WIRELESS (INFRASTRUCTURE)] and [WIRELESS(AP MODE)] cannot be enabled at the same time.</p> <p>To connect with [WIRELESS (INFRASTRUCTURE)], set [WIRELESS(AP MODE)] to [DISABLE] and then set [WIRELESS (INFRASTRUCTURE)] to [ENABLE].</p> <p>To connect with [WIRELESS (AP MODE)], set [WIRELESS (INFRASTRUCTURE)] to [DISABLE] and then set [WIRELESS (AP MODE)] to [ENABLE].</p>	Connecting via Wireless LAN
[WIRELESS (INFRASTRUCTURE)] The machine is not connected to the wireless LAN access point.	<p>Check whether the wireless LAN access point is turned on.</p> <p>Check the settings of the wireless LAN access point, and perform manual or automatic setup.</p> <p>Restart the wireless LAN function.</p> <p>Select [ADMIN SETUP] > [NETWORK SETUP] > [ENABLING DEFAULT GATEWAY] > [WIRELESS (INFRASTRUCTURE)], and then select [RECONNECTION].</p> <p>Place the machine in a location near the wireless LAN access point with high visibility. (A distance of 30 m or less is recommended)</p> <p>Do not place an electric product that emits weak radio waves (such as a microwave oven or a digital cordless telephone) near the machine.</p> <p>If there is metal, aluminum window frame, or a reinforced concrete wall between the machine and the wireless LAN access point, connections may be harder to establish.</p>	Connecting via Wireless LAN











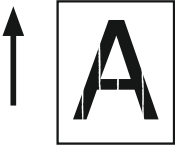

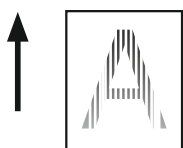
Cause	Remedy	Reference
[Wireless (AP Mode)] A wireless device (such as a computer, tablet, or smartphone) is not connected to the machine.	<p>Check whether [WIRELESS (AP MODE)] is set to [ENABLE] in the machine.</p> <p>Check the SSID/password of the machine, and perform manual setup.</p> <p>Perform connection in a location near the machine with good visibility.</p> <p>A maximum of four devices can be connected to the machine with the wireless (AP mode). Additional devices cannot be connected. Try connecting again after disconnecting a device.</p>	Connecting via Wireless LAN
The IP addresses are incorrect.	<p>Check whether the IP address of the machine matches the IP address of the machine set in the computer.</p> <p>Check whether the IP address is the same as another device.</p> <p>Check whether the IP address, subnet mask, and gateway address are correct.</p>	Checking Information About the Machine
The WSD port is being used.	Change the destination port for printing to the standard TCP/IP port.	-





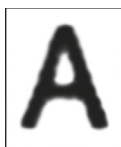
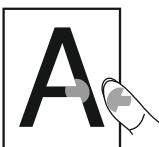

USB Connection Problems

Cause	Remedy	Reference
The cable standard does not match.	Use a USB cable that conforms to the USB 2.0 standard.	-
A USB hub is being used.	Directly connect the machine to the computer.	Connecting a USB Cable
The printer driver is not installed correctly.	Reinstall the printer driver.	Installing the Printer Driver to a Computer

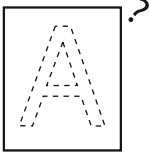
Print Result Problems

List of Print Result Problems

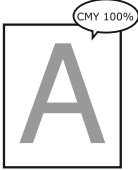
<p>White streaks appear in the vertical direction</p>  <p>Feed direction</p>	<p>Horizontal white streaks periodically appear in the paper feed direction</p>  <p>Feed direction</p>	<p>The printing is faint in the vertical direction</p>  <p>Feed direction</p>
<p>Printing is light</p> 	<p>White dots and lines appear</p> 	<p>Condensation occurs in the printed paper</p> 
<p>Streaks appear in the vertical direction</p>  <p>Feed direction</p>	<p>Dots and horizontal streaks periodically appear in the paper feed direction</p>  <p>Feed direction</p>	<p>White background areas are faintly dirty</p> 
<p>Bleeding occurs around text</p> 	<p>Toner comes off when rubbed</p> 	<p>Gloss is uneven</p> 
<p>Black dots or white dots appear</p> 	<p>Dirt is printed</p> 	<p>The entire page is printed in black</p> 

Nothing is printed 	Parts of the image are missing 	The area around the image is dirty 
The colors of the image are unexpected 	The black of CMY 100% is light 	The precision of barcode reading is low 

White Streaks Appear in the Vertical Direction



Cause	Remedy	Reference
The LED head is dirty.	Wipe the LED head clean with a soft tissue.	Cleaning the LED Head
Toner is low.	If [REPLACE TONER] or [TONER EMPTY] is displayed, replace the toner cartridge.	Replacing the Toner Cartridge
The lightproof film of the image drum unit is dirty.	Wipe the lightproof film clean with a soft tissue.	Replacing the Image Drum Unit
The image drum unit is not set correctly.	Set the image drum unit correctly.	Replacing the Image Drum Unit
Foreign material is stuck in the image drum unit.	Replace the image drum unit.	Replacing the Image Drum Unit

Horizontal White Streaks Periodically Appear in the Paper Feed Direction



Cause	Remedy	Reference
The image drum unit is not set correctly.	Set the image drum unit correctly.	Replacing the Image Drum Unit
The image drum is dirty.	Enable drum cleaning. The lifetime of the image drum unit is shorter when this is set to ON.	Using the Operation Panel
The image drum is dirty.	Replace the image drum unit.	Replacing the Image Drum Unit

The Printing Is Faint in the Vertical Direction

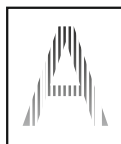

Cause	Remedy	Reference
The LED head is dirty.	Wipe the LED head clean with a soft tissue.	Cleaning the LED Head
Toner is low.	If [REPLACE TONER] or [TONER EMPTY] is displayed, replace the toner cartridge.	Replacing the Toner Cartridge

Printing Is Light



Cause	Remedy	Reference
Toner is low.	If [REPLACE TONER] or [TONER EMPTY] is displayed, replace the toner cartridge.	Replacing the Toner Cartridge
The paper contains humidity.	Use paper that is stored in an environment with suitable temperature and humidity.	Loading Paper
The paper is not suitable. The paper weight setting is not suitable.	Set [MENUS] > [FEEDER CONFIG] > [MEDIaweIGHT] to a suitable value on the operation panel. Or, set [MEDIaweIGHT] to a heavier value.	Loading Paper
The toner save mode is enabled	Set [ADMIN MENU] > [PRINT SETUP] > [TONER SAVE] to [OFF] in the menu.	Reducing Toner Consumption when Printing

White Dots and Lines Appear



Cause	Remedy	Reference
The paper contains humidity or is dry.	Use paper that is stored in an environment with suitable temperature and humidity.	Loading Paper

Condensation Occurs in the Printed Paper



Cause	Remedy	Reference
The paper contains humidity.	Use paper that is stored in an environment with suitable temperature and humidity.	Loading Paper
The machine is used in a location with high humidity or rapid changes in temperature and humidity.	Use the machine in an environment with suitable temperature and humidity.	Installation

Streaks Appear in the Vertical Direction



Cause	Remedy	Reference
Toner is low.	If [REPLACE TONER] or [TONER EMPTY] is displayed, replace the toner cartridge.	Replacing the Toner Cartridge
The image drum is damaged.	Replace the image drum unit.	Replacing the Image Drum Unit

Dots and Horizontal Streaks Periodically Appear in the Paper Feed Direction

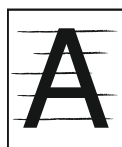

Cause	Remedy	Reference
If the period is approximately 63 mm, the glossy cylinder of the image drum is damaged or dirty.	Gently wipe it with a soft tissue. Replace the image drum unit if it is damaged.	Replacing the Image Drum Unit
If the period is approximately 26 mm, foreign material is attached to the electrostatic roller in the image drum.	Open and close the top cover or feeder cover, and perform printing again.	Names of Components
The image drum unit has been exposed to light.	Return the image drum unit to the inside of the machine and do not use the machine for several hours. If this does not solve the problem, replace the image drum unit.	Replacing the Image Drum Unit

White Background Areas Are Faintly Dirty



Cause	Remedy	Reference
The paper is has an electrostatic charge.	Use paper that is stored in an environment with suitable temperature and humidity.	Loading Paper
Heavy paper is being used.	Use lighter paper.	Loading Paper
Toner is low.	If [REPLACE TONER] or [TONER EMPTY] is displayed, replace the toner cartridge.	Replacing the Toner Cartridge

Bleeding Occurs Around Text

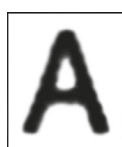

Cause	Remedy	Reference
The LED head is dirty.	Wipe it clean with a soft tissue.	Cleaning the LED Head
The paper contains humidity.	Replace the paper with new paper.	Loading Paper

Toner Comes off When Rubbed

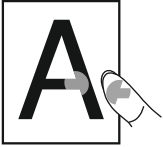

Cause	Remedy	Reference
The paper weight setting is not suitable.	Set [MENUS] > [FEEDER CONFIG] > [MEDIaweIGHT] to a suitable value on the operation panel. Or, set [MEDIaweIGHT] to a heavier value.	Loading Paper

Gloss Is Uneven



Cause	Remedy	Reference
The paper weight setting is not suitable.	Set [MENUS] > [FEEDER CONFIG] > [MEDIaweIGHT] to a suitable value on the operation panel. Or, set [MEDIaweIGHT] to a heavier value.	Loading Paper

Black Dots or White Dots Appear



Cause	Remedy	Reference
If the period is approximately 63 mm, the glossy cylinder of the image drum is damaged or dirty.	Gently wipe the image drum with a soft tissue. Replace the image drum unit if it is damaged.	Replacing the Image Drum Unit

Dirt Is Printed



Cause	Remedy	Reference
The paper contains humidity.	Replace the paper with new paper.	Loading Paper

The Entire Page Is Printed in Black

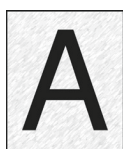

Cause	Remedy	Reference
The machine may have failed.	Contact your dealer.	-

Nothing Is Printed

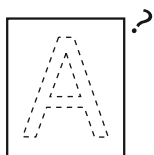

Cause	Remedy	Reference
The machine may have failed.	Contact your dealer.	-

Parts of the Image Are Missing



Cause	Remedy	Reference
The paper contains humidity.	Replace the paper with new paper.	Loading Paper

The Area Around the Image Is Dirty



Cause	Remedy	Reference
The image is not reduced to a ratio that matches the paper size.	Reduce the image to a ratio that matches the paper size.	Keeping the Page Layout when Resizing a Document

The Colors of the Image Are Unexpected



Cause	Remedy	Reference
Toner is low.	If [REPLACE TONER] or [TONER EMPTY] is displayed, replace the toner cartridge.	Replacing the Toner Cartridge
The toner adjustment was changed.	The toner adjustment was changed. Perform color matching from the printer driver.	Changing the Color Settings
The color balance has not been adjusted.	Select [CALIBRATION] in the menu, and execute [ADJUST DENSITY], or [CYAN TUNING], [MAGENTA TUNING], or [YELLOW TUNING].	Correcting the Color Density Adjusting the Color Balance (Density)
Color shift has not been adjusted.	Open and close the top cover. Or, execute [CALIBRATION] > [ADJUST REGISTRATION] on the menu.	Names of Components Menu List
[Replace mono barcode with cyan] is enabled.	From the [Setup] tab, go to [Barcode correction] > [Options] and deselect [Replace mono barcode with cyan].	Correcting Barcodes for Printing
Bar Width Adjustment is enabled.	Disable Bar Width Adjustment on the [Setup] tab > [Barcode Correction] > [Options] of the printer driver.	Correcting Barcodes for Printing

The Black of CMY 100% Is Light



Cause	Remedy	Reference
[CMY100% DENSITY] is set to [ENABLE].	Set [ADMIN MENU] > [COLOR MENU] > [CMY100% DENSITY] to [DISABLE] on the menu.	

The Precision of the Barcode Reading Is Low



Cause	Remedy	Reference
The color of barcodes/two-dimensional barcodes is light	<p>Disable the toner save function if it is enabled.</p> <p>If the remaining toner is low, replace the toner cartridge.</p>	<p>Reducing Toner Consumption when Printing</p> <p>Replacing the Toner Cartridge</p>
Barcodes/two-dimensional barcodes are printed in a color that is difficult to scan	Create barcodes/two-dimensional barcodes in cyan (RGB 0,255,255), and set the color setting of the printer driver to [Automatic] for printing.	Correcting Barcodes for Printing
Small barcodes/two-dimensional barcodes are printed in black	<p>If the size of the barcodes/two-dimensional barcodes to print can be changed, increase the size for printing.</p> <p>If the color can be set for barcodes/two-dimensional barcodes in the application, set the color to cyan (RGB 0,255,255), and set the color setting of the printer driver to [Automatic] and perform printing.</p> <p>If the color of barcodes/two-dimensional barcodes is fixed to black, select [Replace mono barcode with cyan] in [Barcode Correction], and perform printing.</p>	Correcting Barcodes for Printing
	<p>Disable [Adjust ultra fine lines] in [Advanced] in the printer driver.</p> <p>If the bar width can be adjusted in the application, set a bar width that is narrower than the width of the space, and perform printing.</p> <p>If the bar width cannot be adjusted in the application, set a narrower bar width in [Bar Width Adjustment] in [Barcode Correction], and perform printing.</p> <p>If the bar width cannot be adjusted in the application and the printer driver is not used, set a narrower bar width in [ADMIN SETUP] > [PRINT SETUP] > [BARCODE ADJUST] in the panel settings of the machine, and perform printing.</p>	<p>Correcting Faintness in Thin Lines and Small Text</p> <p>Correcting Barcodes for Printing</p>

Software Problems

Web Browser Problems

Symptom	Cause/Solution	Reference
Cannot connect to the machine.	The LAN cable is disconnected. Check the connection of the LAN cable.	Connecting a LAN Cable
	The IP addresses are incorrect. Check the IP address of the machine, and enter the correct address.	Starting the Webpage

Windows Problems

USB Connection Problems

Symptom	Cause/Solution	Reference
An icon for the machine is not created in [Devices and Printers].	The printer driver is not installed correctly. Correctly reinstall the printer driver.	Installing the Printer Driver to a Computer
Another printer driver cannot be installed when a printer driver is already installed.	Refer to the reference procedure to execute a custom installation.	Installing Software
An error message such as "Failed to install the printer driver" is displayed.	Use plug-and-play. Follow the procedure indicated below. <ol style="list-style-type: none">1. Make sure that the machine and the computer are turned off.2. Connect a USB cable.3. Turn on the machine.4. Turn on the computer.5. When [Found New Hardware Wizard] is displayed, follow the instructions on the screen to execute setup.	-

Problems Common to the Printer Driver and Utilities

Symptom	Cause/Solution
[Help] is not displayed.	The help function is not supported.
The [User Account Control] screen is displayed.	The [User Account Control] screen may be displayed when starting the installer or a utility. Click [Yes] or [Continue] to execute the installer or utility as an administrator. If you click [NO], the installer or utility is not started.
The [Program Compatibility Assistant] screen is displayed.	If the [Program Compatibility Assistant] dialog box is displayed after installation is complete (including when the installation is stopped before it is complete), make sure to click [This program installed].

Machine Problems

The Machine Does Not Operate

Cause	Remedy	Reference
The power cord is not inserted properly.	Insert the power cord fully.	Turning On the Machine
This machine is not turned on.	Turn the machine on.	Turning On the Machine

Nothing Is Displayed on the Screen when the Power Is Turned On

Cause	Remedy	Reference
The power cord is disconnected.	Insert the power cord fully.	Turning On the Machine
A power failure has occurred.	Check whether power is supplied to the outlet.	-

Printing Does Not Start

Cause	Remedy	Reference
An error is displayed.	Check the error messages and follow the on-screen instructions.	List of Messages
The LAN cable/USB cable is not inserted.	Insert the LAN cable/USB cable fully.	Using the Machine
There is a problem with the LAN cable/USB cable.	Use another LAN cable/USB cable.	-
The LAN cable/USB cable does not match the required standard.	Use a cable that conforms to the USB 2.0 standard. Use a cable that conforms to the Ethernet 10BASE-T/100BASE-TX standard.	-

Cause	Remedy	Reference
There may be a problem with the print function.	Execute [PRINT INFO] > [CONFIGURATION] on the operation panel to print the settings, and check the print performance.	Printing and Checking a Report
The communication protocol is disabled.	Select [ADMIN SETUP] > [NETWORK SETUP] in the menu, and enable the communication protocol that is used.	-
The printer driver is not selected.	Set the printer driver as the default printer.	-
The output port of the printer driver is incorrect.	Specify the output port where the LAN cable/USB cable is connected.	-
The machine is warming up to recover from the Power Save mode or Sleep mode.	Lengthen the time until the machine enters the Power Save mode or Sleep mode. Select [MENUS] > [SYSTEM ADJUST] > [POW SAVE TIME] or [SLEEP TIME] on the operation panel, and set an appropriate time.	Setting the Power Save Mode Transition Time Setting the Sleep Mode Transition Time
The image drum cleaning operation may be executing.	Wait until the machine finishes.	-
The temperature of the fuser unit is being adjusted.	Wait until the machine finishes.	-
Data is being processed from another interface.	Wait until the printing process is complete.	-

Print Data Is Not Sent

Cause	Remedy	Reference
The LAN cable/USB cable is damaged.	Connect a new cable.	-
The computer has timed out.	Set a longer timeout period.	-

An Abnormal Smell Is Emitted

Cause	Remedy	Reference
The machine is not level.	Install the machine in a flat and stable location.	-
Paper waste or foreign material is inside the machine.	Inspect the inside the machine and remove the material.	-

A Resonant Sound Is Emitted

Cause	Remedy	Reference
Printing is being performed on heavy paper, etc. when the internal temperature of the machine has risen.	This is not a problem with the machine. Keep using the machine as it is.	-

Printing Stops Before It Is Complete

Cause	Remedy	Reference
Temperature adjustment is being performed because the internal temperature of the machine has risen due to continuous printing over a long period, etc.	Wait until the machine finishes. Printing will automatically resume when the temperature of the machine is suitable.	-
The temperature of the fuser unit is being adjusted.	Wait until the machine finishes.	-

Memory Runs Out

Cause	Remedy	Reference
The print data is complex.	Use simpler print data.	-

Printing Is Slow

Cause	Remedy	Reference
Printing is also being processed on the computer.	Use a computer with a faster processing speed.	-
Select [Fine / Detail (1200 x 1200 dpi)] in [Quality] on the [Setup] tab of the printer driver.	Select [Normal (600 x 600 dpi)] or [Draft (600 x 600 dpi)] in [Quality] on the [Setup] tab of the printer driver.	-
The print data is complex.	Use simpler print data.	-

The Power Turns Off Automatically

Cause	Remedy	Reference
If the machine is not used for a certain period of time (4 hours by default), it automatically turns off.	To prevent the power from turning off, set [ADMIN SETUP] > [POWER SETUP] > [AUTO PW OFF] to [DISABLE] on the operation panel.	Setting the Auto Power Off Time

Paper Problems

Paper Jams Frequently Occur/The Paper Is Pulled in at an Angle

Cause	Remedy	Reference
The machine is not level.	Install the machine in a flat and stable location.	-
The paper is too light or too heavy.	The paper is too light or too heavy. Use paper that is suitable for the machine.	Loading Paper
The paper contains humidity or has an electrostatic charge.	Use paper that is stored in an environment with suitable temperature and humidity.	Loading Paper
The paper is wrinkled or warped.	Use paper that is suitable for the machine. If the paper is warped, fix it.	Loading Paper
The paper is not loaded straight.	Align the paper guide with the paper.	Loading Paper

The Machine Does Not Recover When the Paper Jam Is Removed

Cause	Remedy	Reference
The machine may not recover unless the top cover or feeder cover is opened and closed.	Open and close the top cover or feeder cover.	Names of Components
The combination of the cut type setting and paper sensor position of the machine does not match.	Change the position of the top sensor and bottom sensor so that they do not overlap if their positions were matching. Change the position of the top sensor and bottom sensor so that they match if they were not overlapping.	Setting the Paper Sensors

The Paper Curls/The Paper Wrinkles

Cause	Remedy	Reference
The paper contains humidity or has an electrostatic charge.	Use paper that is stored in an environment with suitable temperature and humidity.	Loading Paper
Light paper is being used.	Set [MENUS] > [FEEDER CONFIG] > [MEDIaweIGHT] to a lighter value on the operation panel.	Loading Paper

The Paper Gets Stuck in the Roller of the Fuser Unit

Cause	Remedy	Reference
The paper weight setting is not suitable.	Set [MENUS] > [FEEDER CONFIG] > [MEDIaweIGHT] to a suitable value on the operation panel. Or, set [MEDIaweIGHT] to a heavier value.	Setting Paper Information on the Operation Panel
Light paper is being used.	Use heavier paper.	Paper Specifications
There is an area near the tip of the paper that is almost completely printed.	Try adding a margin to the paper tip.	-

Paper Sticks to the Transfer Belt Unit

Cause	Remedy	Reference
Light paper or weak paper is being used.	Use heavier paper.	-

Paper Corners Are Folded

Cause	Remedy	Reference
The paper is curled.	The paper is curled. Use paper that is stored in an environment with suitable temperature and humidity.	Loading Paper

The „308:PAPER JAM“ error occurs when paper is not loaded

Cause	Remedy	Reference
There may have been a problem with the position of the paper sensors when sensor calibration was executed, which caused an invalid value to be detected.	Execute [BOOT MENU] > [SENSOR RE-SET] on the operation panel.	 BOOT MENU Adjusting the Paper Sensors (Sensor Calibration)

When a Power Failure Occurs

When a power failure occurs, the machine operates as follows.

Machine Status	Operation
Receiving	Reception is interrupted.
Printing	Printing is interrupted. When the power supply recovers, start printing again.
Standby	Printing cannot be started.

If a power failure occurs while the machine is turned on, the machine does not turn on when the power supply resumes. If you want the machine to automatically turn on when the power supply resumes after a power failure, set [BOOT MENU] > [POWER RETURN] to [ALWAYS ON] or [LAST STATE].

Operation is not guaranteed if an uninterruptible power supply (UPS) or inverter is used. Do not use an uninterruptible power supply (UPS) or inverter.

Moving the Machine

- Turn off the machine.
- For information on turning off the machine, refer to “Turning Off the Machine”.
- Unplug all the cables.

Power cord

LAN cable/USB cable

- Remove the loaded paper.
- Lift up the machine and move it to the destination.

Transporting the Machine



Use the packaging, cushioning material, and cover toner that came with the machine when the product was purchased.

- Turn off the machine.
 - ▶ For information on turning off the machine, refer to “Turning Off the Machine”.
- Unplug all the cables.
 - ▶ Power cable
 - ▶ LAN cable/USB cable
- Remove the loaded paper.
- If a wireless LAN module is attached, remove it.
- Remove the toner cartridge.
- Attach the cover toners that were stored to replace the removed toner cartridge.
- Attach the cushioning materials.
- Insert the machine into the packaging.

Before Leaving the Machine

Before leaving the machine, it is strongly recommended that you erase the information registered or saved to the machine.

To delete the information, execute [ADMIN SETUP] > [OTHERS SETUP] > [ERASE PRIVACY DATA].

The information saved in the machine includes the following items.

- Administrator password
- Values registered to menus
- Demonstration page data registered by users
- Form data registered by users
- Saved menu settings
- Certificate

Management Software

Type of Software

- System Requirements

Windows 10/Windows 8.1/Windows 8/Windows 7

Windows Server 2016/Windows Server 2012 R2/Windows Server 2012

Windows Server 2008 R2/Windows Server 2008

Software Name	Description
Configuration Tool	Changes the menu settings of the machine, performs cloning, and sets the network of the machine. Also enables form data to be registered and deleted.
Web Page	Configures the network settings of the machine.
Status Monitor	A utility for monitoring the status of the printer. Also enables the information included in the following reports to be retrieved as a CSV file. Setting Error Log

Installing Software



Download the driver from dtm-print.eu/downloads and follow the instructions from the driver or scan the QR code to watch the installing video.

Web Page

Configures the network settings of the machine.

Web Page Settings

- System

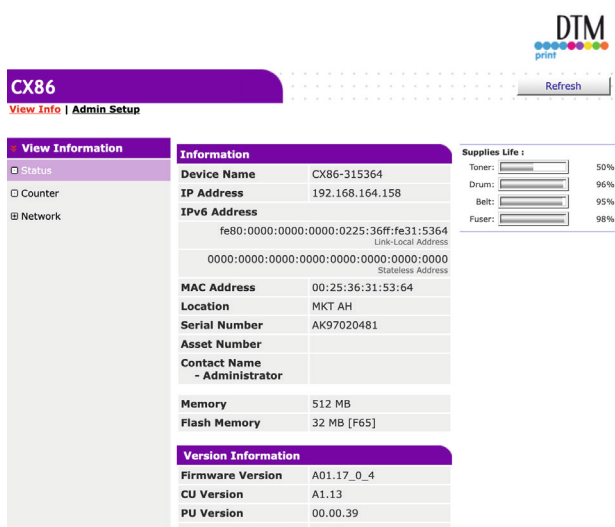

CX86
View Info | Admin Setup

View Information

- Status
- Counter
- Network

Information

Device Name: CX86-315364
 IP Address: 192.168.164.158
 IPv6 Address: fe80:0000:0000:0000:0225:36ff:fe31:5364 (Link-Local Address), 0000:0000:0000:0000:0000:0000:0000:0000 (Stateless Address)
 MAC Address: 00:25:36:31:53:64
 Location: MKT AH
 Serial Number: AK97020481
 Asset Number:
 Contact Name - Administrator:
 Memory: 512 MB
 Flash Memory: 32 MB [F65]

Supplies Life

Toner: 50%
 Drum: 96%
 Belt: 95%
 Fuser: 98%

Version Information

Firmware Version: A01.17_0_4
 CU Version: A1.13
 PU Version: 00.00.39

Item	Description
Status	Displays the current status of the machine. Displays warnings and errors that have occurred in the machine. Also enables you to check the operation status of the network services, a list of the machine information, and the IP address set in the machine.
Counter	Displays the print count.
Network	Enables you to check information on the network settings, such as the general information, TCP/IP status, and maintenance information.

- Admin Setup

This function is displayed when you are logged in to the machine as an administrator.

- Network Management

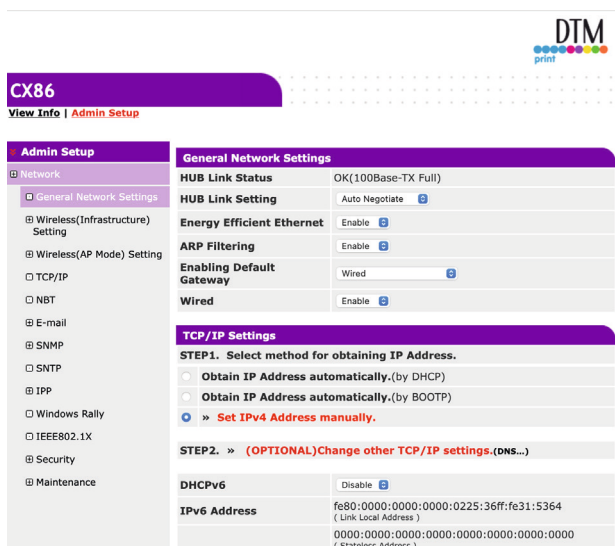

CX86
View Info | Admin Setup

Admin Setup

- Network
 - General Network Settings
 - Wireless(Infrastructure) Setting
 - Wireless(AP Mode) Setting
 - TCP/IP
 - NBT
 - E-mail
 - SNMP
 - SNTP
 - IPP
 - Windows Rally
 - IEEE802.1X
 - Security
 - Maintenance

General Network Settings

HUB Link Status: OK(100Base-TX Full)
 HUB Link Setting: Auto Negotiate
 Energy Efficient Ethernet: Enable
 ARP Filtering: Enable
 Enabling Default Gateway: Wired
 Wired: Enable

TCP/IP Settings

STEP1. Select method for obtaining IP Address.

- Obtain IP Address automatically.(by DHCP)
- Obtain IP Address automatically.(by BOOTP)
- Set IPv4 Address manually.

STEP2. (OPTIONAL)Change other TCP/IP settings.(DNS...)

DHCPv6: Disable

IPv6 Address: fe80:0000:0000:0000:0225:36ff:fe31:5364 (Link Local Address), 0000:0000:0000:0000:0000:0000:0000:0000 (Stateless Address)



Item		Description
General Network Settings		Configures the network connection method.
Wireless LAN (Infrastructure) Setting		Configures wireless LAN (infrastructure).
Wireless (AP Mode) Setting		Configures wireless (AP mode) connections.
TCP/IP		Configures information regarding TCP/IP.
NBT		Configures information regarding NetBIOS over TCP.
E-mail	Alert Setting	Configures e-mail notifications for errors that have occurred in the machine, etc.  E-mail alert
SNMP	Setting	Configures SNMP.
	Trap	Configures SNMP Trap.
SNTP		Configures SNTP.
IPP	Setting	Configures information regarding IPP printing.
Windows Rally		Configures information regarding Windows Rally.
IEEE802.1X		Configures information regarding IEEE802.1X/EAP.
Security	Protocol ON/OFF	Disables network protocol and network services that are not used.
	IP Filtering	Restricts access via TCP/IP. Also supports access from outside the company. However, this function requires knowledge regarding IP addresses. Incorrect settings may lead to serious trouble, such as becoming unable to access the machine from the network.
	MAC Address Filtering	Restricts access by MAC address. Also supports access from outside the company. However, this function requires knowledge regarding MAC addresses. Incorrect settings may lead to serious trouble, such as becoming unable to access the machine from the network.
	Encryption (SSL/TLS)	Enables communication between the computer (client) and the machine to be encrypted.
	IPSec	Enables communication between the computer (client) and the machine to be encrypted and modification to be prevented.
	Web Page Authentication Method	Configures the Web Page authentication method.

Item		Description
Maintenance	Restart/Initialize	Restarts or initializes the network. When the network is restarted, the Web page is not displayed from a Web browser until the restart process is complete. When the network is initialized, information that has been set manually is lost because the IP address is initialized. The Web page also cannot be displayed.
	Network Scale	This setting enables the machine to operate on the network more efficiently. When using a hub with the spanning tree function, this setting is effective if the machine is connected to a computer via a cross cable.

Starting the Web Page



- Set the security of your browser to the medium level or enable cookies.
- A password is required to enter the [Admin Setup] menu. The default password is “999999.”
- You must log in as the administrator to change the settings of the machine via the Web page.

The example environment used in the following description is indicated below.

- Machine name: CX86e
- Machine IP address: 192.168.0.2

Start the Web browser.

Enter the URL (“http://(IP address of the machine)”) in the address bar, and press the <Enter> key.

- For information on checking the IP address of the machine, refer to “Printing and Checking a Report”.

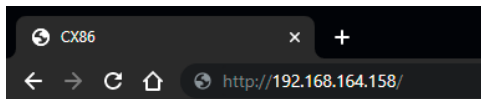

- When including a one digit or two digit number in the IP address, do not enter zeros before the number. Doing so may prevent communication from being performed correctly.
- Correct: http://192.168.0.2/
- Incorrect: http://192.168.000.002/

Logging In as the Administrator

You must log in as the administrator to change the settings of the machine via a Web browser.

Click [Admin Login].

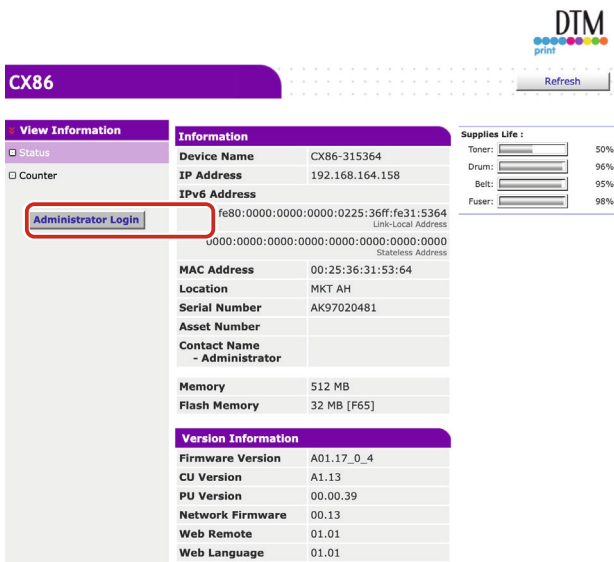

The screenshot shows the printer's web interface. At the top right is the DTM logo. Below it is a 'Refresh' button. The main content area is divided into sections: 'View Information' (with sub-sections for Status and Counter), 'Information' (with fields for Device Name, IP Address, IPv6 Address, MAC Address, Location, Serial Number, Asset Number, Contact Name, Memory, and Flash Memory), and 'Version Information' (with fields for Firmware Version, CU Version, PU Version, Network Firmware, Web Remote, and Web Language). On the right side, there is a 'Supplies Life' section with progress bars for Toner, Drum, Belt, and Fuser. A red box highlights the 'Administrator Login' button in the Information section.

Enter "admin" in [User Name] and the current password in [Password], and click [OK].

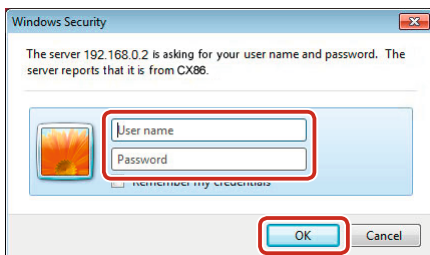

- The password is the same as the administrator password for the operation panel.
- The default administrator password is "999999." If the administrator password has been changed, enter the changed password. Set the printer information that can be checked on the network, and click [OK] or [SKIP].

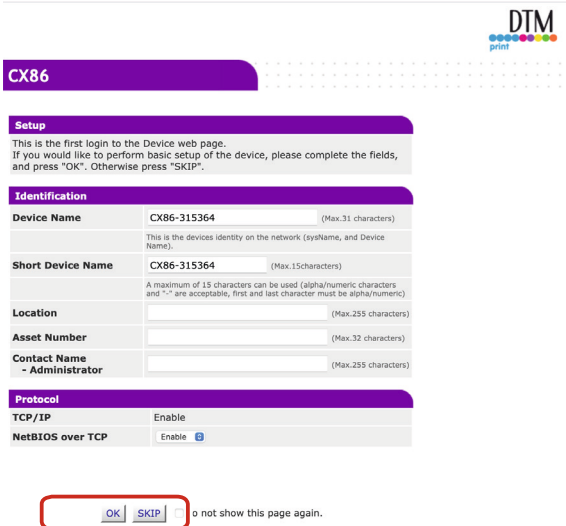

- Settings can be omitted by clicking [SKIP].
- Select [Do not show this page again] and click [OK] or [SKIP] to prevent this from being displayed again. The following screen is displayed.

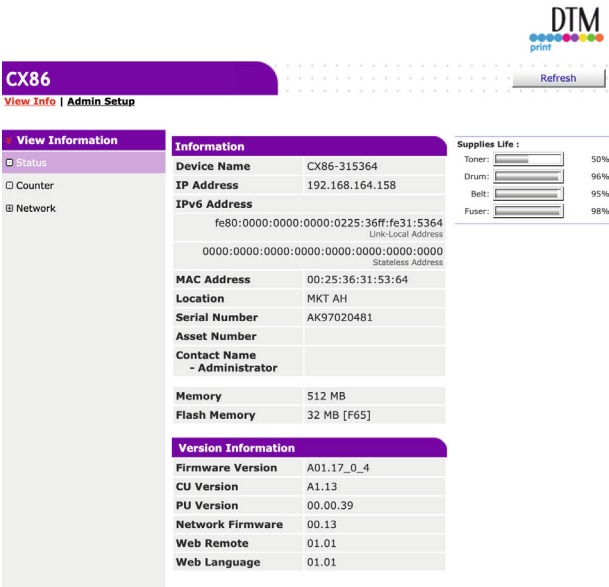

Checking or Changing the Status of the Machine

The following operations can be executed from the Web page on a computer.

- Displaying the machine status
- Configuring the machine

System Requirements



- Set the security of your browser to the medium level or enable cookies.
- A password is required to enter the [Admin Setup] menu. The default password is "999999."
- You must log in as the administrator to change the settings of the machine via the Web page.

Configuring the Network



- To connect via a LAN cable, refer to "Connecting a LAN Cable".
- To connect via a USB cable, refer to "Connecting a USB Cable".
- To connect via wireless LAN, refer to "Connecting via Wireless LAN".

The example environment used in the following description is indicated below.

- Machine name: CX86e
- Machine IP address: 192.168.0.2

- Displaying the machine status

Open the Web page of this machine.



- For information on starting the Web page, refer to "Starting the Web Page".

Log in as the administrator.

The following screen is displayed.

You can check the counter information and network information of the machine.

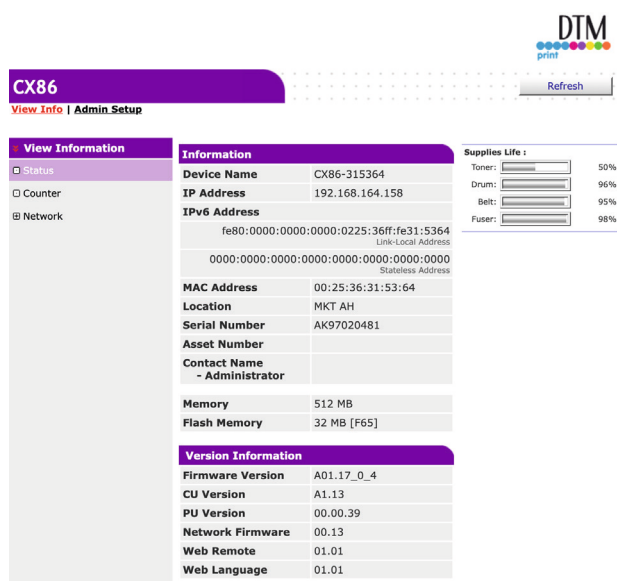

DTM print

CX86
View Info | Admin Setup

View Information

- Status
- Counter
- Network

Information

Device Name CX86-315364

IP Address 192.168.164.158

IPv6 Address
fe80:0000:0000:0000:0225:36ff:fe31:5364
Link-Local Address
0000:0000:0000:0000:0000:0000:0000:0000
Stateless Address

MAC Address 00:25:36:31:53:64

Location MKT AH

Serial Number AK97020481

Asset Number

Contact Name - Administrator

Memory 512 MB

Flash Memory 32 MB [F65]

Version Information

Firmware Version A01.17_0_4

CU Version A1.13

PU Version 00.00.39

Network Firmware 00.13

Web Remote 01.01

Web Language 01.01

Supplies Life :

Toner: 50%

Drum: 96%

Belt: 95%

Fuser: 98%

The settings of the machine can be changed from the [Admin Setup] tab.

Encrypting Communication (SSL/TLS)

You can encrypt the communication between the computer and the machine. Communication is encrypted via SSL/TLS in the following cases. A certificate is installed in the machine by default, which enables communication using HTTPS to be performed.

- Creating a Certificate

A certificate can be used when sending data to the machine on the network. This section describes how to create a certificate using the Web page.

The following two types of certificates can be created.

- Self-signed certificate
A certificate issued by the machine.
- CA certificate
A certificate issued and signed by an external certificate authority for the CSR (certificate signature request) created by the machine.



- Confirm that the previously installed certificate has been deleted before creating a new certificate.
- If an IP address was set in the [Common Name] of the certificate, the certificate is disabled if the IP address of the printer is changed after creating the certificate. Create the certificate again.

Open the Web page of this machine.



- For information on starting the Web page, refer to "Starting the Web Page".

Log in as the administrator.

Select [Admin Setup].

Select [Network] > [Security] > [SSL/TLS]



- To delete a certificate that is already installed, click [Delete Certificate].

Follow the on-screen instructions to configure the detailed settings.

Confirm the settings, and click [OK].

- ▶ If the certificate is a self-signed certificate, follow the on-screen instructions to close the Web page, and proceed to “Enabling Encryption.”

- ▶ To retrieve a certificate issued by a certificate authority, proceed to step 7.

Follow the on-screen instructions to send the CSR to the certificate authority.

Click [OK].

Follow the on-screen instructions to install the certificate from the certificate authority.

Click [Submit].

Proceed to “Enabling Encryption.”

- Importing a Certificate and Private Key

This section describes how to import a certificate and private key using the Web page.

A certificate and private key that have been issued can be imported in order to use a certificate issued by an external certificate authority.

Open the Web page of this machine.



- For information on starting the Web page, refer to “Starting the Web Page”.

Log in as the administrator.

Select [Admin Setup].

Select [Network] > [Security] > [SSL/TLS]

Select [Using Certificate and Private Key after imported] and import the certificate.



- Certificates in the PKCS#12 format can be imported.

Proceed to “Enabling Encryption.”

- Enabling Encryption

Encryption can be enabled after creating a certificate. This section describes how to enable encryption using the Web page.

When encryption is enabled, the communication is immediately encrypted after the setting is changed from the Web page.

Open the Web page of this machine.



- For information on starting the Web page, refer to “Starting the Web Page”.

Log in as the administrator.

Select [Admin Setup].

Select [Network] > [Security] > [SSL/TLS]

Select [Enabled] for the protocol to encrypt.

Click [Submit].

Exporting a Certificate

This section describes how to export a certificate using the Web page.

The computer may request the certificate of the machine, depending on the function performing communication via SSL/TLS.

In order to enable the computer to request the certificate of the machine, import the certificate of the machine that has been exported to the certificate store of the computer.

Open the Web page of this machine.



- For information on starting the Web page, refer to “Starting the Web Page”.

Log in as the administrator.

Select [Admin Setup].

Select [Network] > [Security] > [SSL/TLS]

Select [Export Certificate] to export the certificate.



- The certificate is exported in the PEM format.

Using IPP

The machine can be added to a computer as an IPP printer.

When IPP printing is enabled, data can be sent to the machine via the Internet.

- Adding the Machine as an IPP Printer

Click [Start], and select [Devices and Printers] > [Add a Printer].

Select [Add a network, wireless or Bluetooth printer] in the [Add a Printer] wizard.

Select [The printer is not in the list] in the list of available printers.

Select [Select the shared printer by name].

Enter "http://(The IP address of this machine)/ipp" or "http://(The IP address of this machine)/ipp/lp," and click [Next].

Click [Have Disk].

Insert the included "Software DVD-ROM" into a computer.

Enter the following value in [Copy manufacturer's files from], and click [Use].

To install the PCL printer driver: "D:¥Drivers¥_PCL"



- The DVD-ROM drive is set to the D drive in the above example.

Select the INF file, and click [Open].

Click [OK].

Select the model, and click [OK].

Click [Next].

Click [Complete].

When installation is complete, print a test page.

Encrypting Communication (IPSec)

You can encrypt the communication between the computer and the machine.

The communication is encrypted with IPSec. When IPSec is enabled, all applications use IPSec for encryption.

50 hosts can be specified with an IP address. Access to the machine from unregistered hosts is refused. Access to unregistered hosts is also disabled.

Configure the computer after configuring the machine.

The pre-shared key must be prepared in advance.

- Configuring the Machine

In order to enable IPSec, the Web page must first be used to configure the machine.



- IPSec communication is performed when IPSec is configured for both the printer and the host. IPSec communication is not performed unless IPSec is configured for the host.
- Make a note of the value specified in this procedure. It is required for configuring IPSec on the computer.

Open the Web page of this machine.



- For information on starting the Web page, refer to "Starting the Web Page".

Log in as the administrator.

Select [Admin Setup].

Select [Network] > [Security] > [IPSec].

Follow the on-screen instructions to configure the detailed settings.



- Either [AH] or [ESP] must be enabled in "Phase2 Proposal."

Click [Submit].

The new setting is enabled after the network function of the machine is restarted.



- If IPSec cannot be set up because the specified parameter is incorrect, the Web page cannot be accessed. In this case, disable IPSec from the operation panel of the machine or initialize the network settings.

Proceed to "Configuring the Computer."

-
- Configuring the Computer
 - ▶ Creating an IP Security Policy
 - ▶ Setting Key Exchange
 - ▶ Setting the IP Filter
 - ▶ Setting the Filter Operations
 - ▶ Assigning an IP Security Policy

Configure IPSec on the computer.

Follow the procedure below in order.



- Configure the machine before configuring the computer.
For details, refer to “Configuring the Machine”.
- Creating an IP Security Policy
- Click [Start], and select [Control Panel] > [System and Security] > [Administrative Tools].
-

Double-click [Local Security Policy].

Click [IP Security Policies on Local Computer] in the [Local Security Policy] window.

Select [Create IP Security Policy] in the [Action] menu.

Click [Next] in [IP Security Policy Wizard].

Enter [Name] and [Description], and click [Next].

Deselect [Activate the default response rule (earlier versions of Windows only)], and click [Next].

Select [Edit Properties], and click [Complete].

- Setting Key Exchange

Select the [General] tab in the IP security policy properties window.

Click [Setup].

Enter a value (in minutes) in [Authenticate and generate a new key after every] in the [Key Exchange Settings] window.



- Enter the same value as specified in [Lifetime] in "Phase1 Proposal" in "Configuring the Machine." [Lifetime] is specified in seconds, but enter a value in minutes in this step.

Click [Methods].

Click [Add] in the [Key Exchange Security Methods] window.

Specify [Integrity algorithm], [Encryption algorithm], and [Diffie-Hellman group].



- Select the same values as specified in [IKE Encryption Algorithm], [IKE Hush Algorithm], and [Diffie-Hellman group] in "Phase1 Proposal" in "Configuring the Machine."

Click [OK].

Click [OK] in the [Key Exchange Security Methods] window.

Click [OK] in the [Key Exchange Settings] window.

- Setting the IP Filter

Select the [Rules] tab in the IP security policy properties window.

Click [Add].

Click [Next] in [Security Rules Wizard].

On the [Tunnel Endpoint] screen, select [This rule does not specify a tunnel], and click [Next].

On the [Network Type] screen, select [All Network Connections], and click [Next].

Click [Add] on the [IP Filter List] screen.

Click [Add] in the [IP Filter List] window.

Click [Next] in [IP Filter Wizard].

Click [Next] on the [IP Filter Description and Mirrored property] screen.

Click [Next] on the [IP Traffic Source] screen.

Click [Next] on the [IP Traffic Destination] screen.

Click [Next] on the [IP Protocol Type] screen.

Click [Complete].

- Setting the Filter Operations

Click [OK] in the [IP Filter List] window.

In [Security Rules Wizard], select the new IP filter in the list, and click [Next].

Click [Add] on the [Filter Action] screen.

Click [Next] in [Filter Action Wizard].

On the [Filter Action Name] screen, enter [Name] and [Description], and click [Next].

On the [Filter Action General Options] screen, select [Negotiate security], and click [Next].

On the [Communicating with computers that do not support IPsec] screen, select [Do not allow unsecured communication], and click [Next].

On the [IP Traffic Security] screen, select [Custom], and click [Setup].

Configure the settings in the [Custom Security Method Settings] window, and click [OK].



- Specify the same values as specified in [ESP Encryption Algorithm], [ESP Authentication Algorithm], [AH Authentication Algorithm], and [Lifetime] in “Phase2 Proposal” in “Configuring the Machine.”

Click [Next] on the [IP Traffic Security] screen.

Select [Edit Properties], and click [Complete].

- Assigning an IP Security Policy

To enable key PFS, select [Use session key perfect forward secrecy (PFS)] in the [Filter Action Properties] window.

To perform IPSec communication with an IPv6 global address, select [Accept unsecured communication, but always respond using IPsec].

Click [OK].

Select the new filter operation, and click [Next].

On the [Authentication Method] screen, select the authentication method, and click [Next].



- If an advance shared key was set in “Configuring the Machine,” enable “Use this string to protect the key exchange

(preshared key)” on the [Authentication Method] screen and enter the preshared key.

- Click [Complete].
- Click [OK] in the IP security policy properties window.
- Select the new IP security policy in the [Local Security Policy] window.
- Select [Assign] in the [Action] menu.
- Confirm that [Yes] is displayed for the [Policy Assigned] of the new IP security policy.
- Click [X] in the [Local Security Policy] window.

Using the IP Address Access Control Function (IP Filter)

IP addresses can be used to control access to the machine. You can configure whether to allow printing or setting from the specified IP address. IP filtering is disabled by default.



- Make sure to specify the correct IP address. If an incorrect IP address is specified, the machine will become unable to be accessed using the IP protocol.
- If IP filtering is enabled, access to hosts not specified in this setting is refused.

Open the Web page of this machine.



- For information on starting the Web page, refer to “Starting the Web Page”.

Log in as the administrator.

Select [Admin Setup].

Select [Network] > [Security] > [IP Filtering].

Follow the on-screen instructions to configure the detailed settings.



- If nothing is registered in [Administrator’s IP Address to Register], the machine may become unable to be accessed, depending on the specified range of IP addresses.
- If you are using a proxy server, the IP address of the host used may not match [Your Current Local Host/Proxy IP Address].

Click [Submit].

- ▶ The new setting is enabled after the network function of the machine is restarted.



- Only IPv4 can be used for IP filtering.

Using the MAC Address Access Control Function

MAC addresses can be used to restrict access to the machine. You can allow or refuse access from specified MAC addresses.



- Make sure to specify the correct MAC address. If an incorrect MAC address is specified, the machine will become unable to be accessed from the network.

Open the Web page of this machine.



- For information on starting the Web page, refer to “Starting the Web Page”.

Log in as the administrator.

Select [Admin Setup].

Select [Network] > [Security] > [MAC Address Filtering].

Follow the on-screen instructions to configure the detailed settings.



- If nothing is registered in [Administrator’s MAC Address to Register], the machine may become unable to be accessed, depending on the specified range of MAC addresses.
- If you are using a proxy server, the MAC address of the host used may not match [Your Current Local Host/Proxy MAC Address].

Click [Submit].

The new setting is enabled after the network function of the machine is restarted.



- Access cannot be individually allowed or refused for each address.

E-Mail Alert

A mail server needs to be configured in advance in order to use this function.

- For details, refer to “E-mail Configuration (Web Page)”.
- Sending Error Notifications via E-mail

Open the Web page of this machine.

- For information on starting the Web page, refer to “Starting the Web Page”.

Log in as the administrator.

Select [Admin Setup].

Select [Network] > [E-mail] > [Alert Settings].

Enter the e-mail address to notify in [Failure Notification Settings].

Click [Setup] for the entered e-mail address.

Click [COPY] to apply the notification conditions to another address.

Select [Upon occurrence of an event] in [Failure Notification Method], and click [To Step 2].

Follow the on-screen instructions to configure the detailed settings.

Select an error or warning to send notification for to display the window for specifying the time difference between when the error occurs and when the notification is sent.

Click [OK].

Click [View a summary of current configuration], confirm the current settings, and click [X] to close the window.

You can also check the current settings for a maximum of two addresses in the main window. Select the address to check from the list box.

Click [Submit].

The new setting is enabled after the network function of the machine is restarted.

- Periodically Sending Error Notifications via E-mail

Open the Web page of this machine.



- For information on starting the Web page, refer to "Starting the Web Page".

Log in as the administrator.

Select [Admin Setup].

Select [Network] > [E-mail] > [Alert Settings].

Enter the e-mail address to notify in [Failure Notification Settings].

Click [Setup] for the entered e-mail address.

Click [COPY] to apply the notification conditions to another address.

Select [Periodically] in [Failure Notification Method], and click [To Step 2].

Follow the on-screen instructions to configure the detailed settings.

Click [OK].

Click [View a summary of current configuration], confirm the current settings, and click [X] to close the window.

You can also check the current settings for a maximum of two addresses in the main window. Select the address to check from the list box.

Click [Submit].

The new setting is enabled after the network function of the machine is restarted.



- Notification e-mail is not sent unless the target error has occurred.

Using SNMPv

Using an SNMP manager that supports SNMPv3 enables the management of the machine to be encrypted via SNMP.

Open the Web page of this machine.



- For information on starting the Web page, refer to “Starting the Web Page”.

Log in as the administrator.

Select [Admin Setup].

Select [Network] > [SNMP] > [Setup].

Follow the on-screen instructions to configure the detailed settings.

Click [Submit].

The new setting is enabled after the network function of the machine is restarted.



- You can use a commercial SNMP manager tool to check and change the settings of the machine. For information on the MIB of the machine, access the “Software DVD-ROM” included with the machine, and check the MIB definition files in the [Misc] > [MIB Files] folder.

Using IEEE802.1X (Wired LAN)

The machine supports IEEE802.1X authentication. IEEE802.1X authentication is performed after enabling it on the Web page and connecting to the authentication switch.

- Using EAP-TLS

This section describes how to set EAP-TLS, which is a type of IEEE802.1X authentication.

Open the Web page of this machine.



- For information on starting the Web page, refer to “Starting the Web Page”.

Log in as the administrator.

Select [Admin Setup].

Select [Network] > [IEEE802.1X].

Select [Enabled] for [IEEE802.1X].

Select [EAP-TLS] in [EAP Type].

Enter the user name in [EAP User].

Select [Do not use SSL/TLS Certificate for EAP authentication], and click [Import].

Enter the file name of the certificate.

Only PKCS#12 files can be imported.

Enter the certificate password, and click [OK].

Select [Authenticate Server], and click [Import].

Enter the file name of the CA certificate, and click [OK].

Specify the certificate of the certificate authority (CA) used for the RADIUS server authentication. PEM, DER, and KCS#7 files can be imported.

Click [Submit].

The new setting is enabled after the network function of the machine is restarted.

Turn off the machine when it becomes online.



- For information on turning off the machine, refer to “Turning Off the Machine”.

Remove the LAN cable from the machine.

Proceed to “Connecting the Machine to an Authentication Switch.”

Using PEAP

This section describes how to set PEAP, which is a type of IEEE802.1X authentication.

Open the Web page of this machine.



- For information on starting the Web page, refer to “Starting the Web Page”.
Log in as the administrator.

Select [Admin Setup].

Select [Network] > [IEEE802.1X].

Select [Enabled] for [IEEE802.1X].

Select [PEAP] in [EAP Type].

Enter the user name in [EAP User].

Enter the password in [EAP Password].

Select [Authenticate Server], and click [Import].

Enter the file name of the CA certificate, and click [OK].

Specify the certificate of the certificate authority (CA) used for the RADIUS server authentication. PEM, DER, and KCS#7 files can be imported.
Click [Submit].

The new setting is enabled after the network function of the machine is restarted.
Turn off the machine when it becomes online.



- For information on turning off the machine, refer to “Turning Off the Machine”.
Remove the LAN cable from the machine.

Proceed to “Connecting the Machine to an Authentication Switch.”

- Connecting the Machine to an Authentication Switch
Make sure that the machine is turned off.

Connect a LAN cable to the network interface connector of the machine.

Insert the other end of the LAN cable into the authentication port of the authentication switch.

Turn on the machine.



- For information on turning on the machine, refer to “Turning On the Machine”.

Set the IP address, etc. of the machine.

Configuring IEEE802.1X (Wireless LAN)

You can use wireless LAN to configure IEEE802.1X authentication. First configure IEEE802.1X authentication on the Web page of the machine, and then configure the wireless connection on the Web page.

- Using EAP-TLS

Open the Web page of this machine.

- For information on starting the Web page, refer to “Starting the Web Page”.

Log in as the administrator.

Select [Admin Setup].

Select [Network] > [IEEE802.1X].

Select [Disabled] for [IEEE802.1X].

Select [EAP-TLS] in [EAP Type].

Enter the user name in [EAP User].

Select [Do not use SSL/TLS Certificate for EAP authentication], and click [Import].



- If you selected [Use SSL/TLS Certificate for EAP authentication], the certificate must be configured in advance on the [SSL/TLS] menu.

Select the file of the certificate.

Only PKCS#12 files can be imported.

Enter the certificate password, and click [OK].

Select [Authenticate Server], and click [Import].



- If you selected [Not authenticate Server], proceed to step 13.

Select the file name of the CA certificate, and click [OK].



-
- Specify the certificate of the certificate authority (CA) used for the RADIUS server authentication. PEM, DER, and PKCS#7 files can be imported.

Click [Submit].

If the machine becomes online, proceed to “Configuring Wireless LAN (WPA/WPA2-EAP).”

- Using PEAP

Open the Web page of this machine.



- For information on starting the Web page, refer to “Starting the Web Page”.

Log in as the administrator.

Select [Admin Setup].

Select [Network] > [IEEE802.1X].

Select [Disabled] for [IEEE802.1X].

Select [PEAP] in [EAP Type].

Enter the user name in [EAP User].

Enter the password in [EAP Password].

Select [Authenticate Server], and click [Import].

- If you selected [Not authenticate Server], proceed to step 11.

Select the file name of the CA certificate, and click [OK].

- Specify the certificate of the certificate authority (CA) used for the RADIUS server authentication. PEM, DER, and PKCS#7 files can be imported.

Click [Submit].

If the machine becomes online, proceed to “Configuring Wireless LAN (WPA/WPA2-EAP).”

- Configuring Wireless LAN (WPA/WPA2-EAP)

Open the Web page of this machine.



- For information on starting the Web page, refer to “Starting the Web Page”.

Log in as the administrator.

Select [Admin Setup].

Select [Network] > [Wireless(Infrastructure)] > [Manual Setup].

Select [Enabled] in [Wireless(Infrastructure)] in [Setup].



- The default setting is [Disabled].

Enter the SSID name of the wireless AP to connect to in [SSID].

Select [WPA/WPA2-EAP] in [Security] in [Security Settings].

When all the basic settings and security settings are complete, click [Submit] on the bottom left of the Web screen to reflect the settings. It may take up to one minute to connect to the wireless AP. If the connection fails, reconfigure the wireless settings from the operation panel again or switch to wired LAN from the operation panel and reconfigure the wireless settings from the Web page.

Configuration Tool

The Configuration Tool enables multiple devices to be managed or configured.

Registering the Machine

When installing the machine for the first time, register it to the Configuration Tool.

Click [Start], and select [General] > [Configuration Tool].

Select [Register Device] from the [Tools] menu.

When the devices that can be registered are displayed, select the machine and click [Register].

Click [Yes] on the confirmation screen.

Starting the Configuration Tool

Click [Start], and select [General] > [Configuration Tool].

Select this machine from [Registered Device Table].

Checking the Status of the Machine

You can check the status and information of the machine.

Click [Start], and select [General] > [Configuration Tool].

Select this machine from [Registered Device Table].

Select the [Device Info] tab.

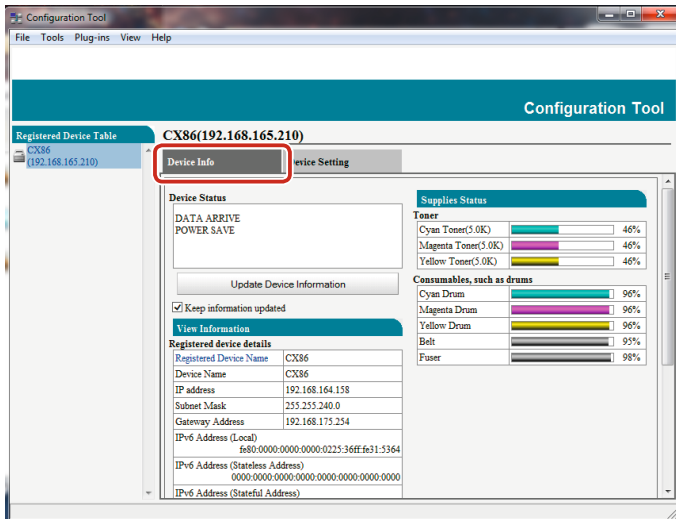

- If the machine is connected to the network, [Device Status] is displayed.
- Click [Update Device Information] to update the information.

Changing the Menu Settings

You can check the status and information of the machine. You can change the menu settings of the machine or copy the settings to another machine. This section describes how to save/restore the menu settings to/from a file.

Saving the Settings to a File

Click [Start], and select [General] > [Configuration Tool].

Select this machine from [Registered Device Table].

Select the [Device Setting] tab.

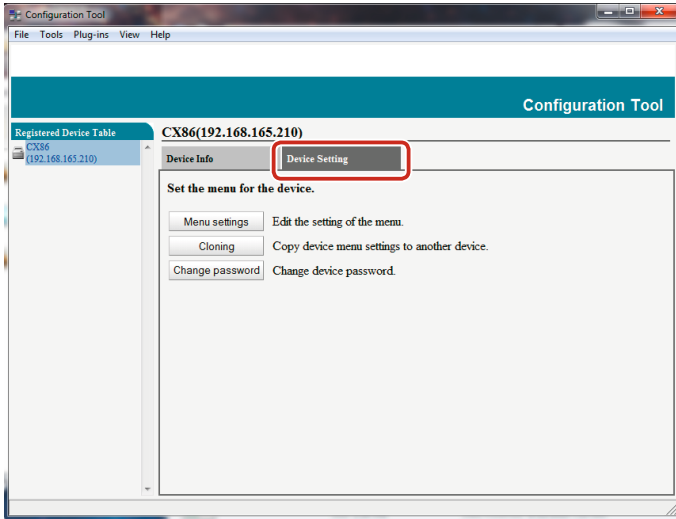

Click [Menu settings].

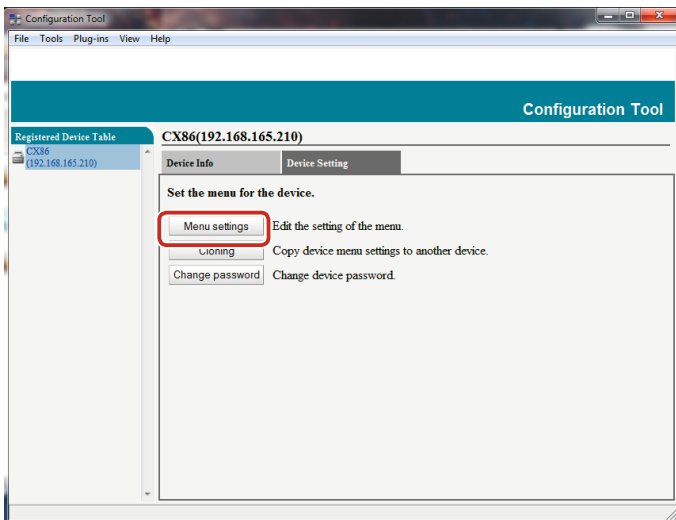

 Click [Backup settings].

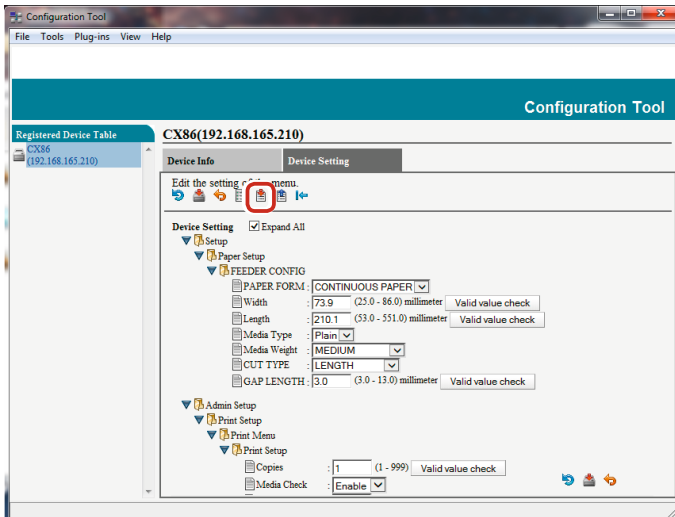

Enter the file name, select the folder to save the file, and click [Save].

Restoring the Settings from a File

Click [Start], and select [General] > [Configuration Tool].

Select this machine from [Registered Device Table].

Select the [Device Setting] tab.

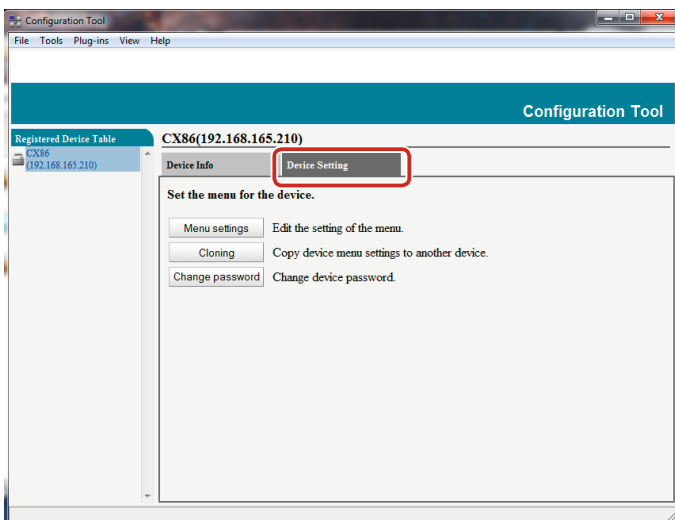

Click [Menu settings].

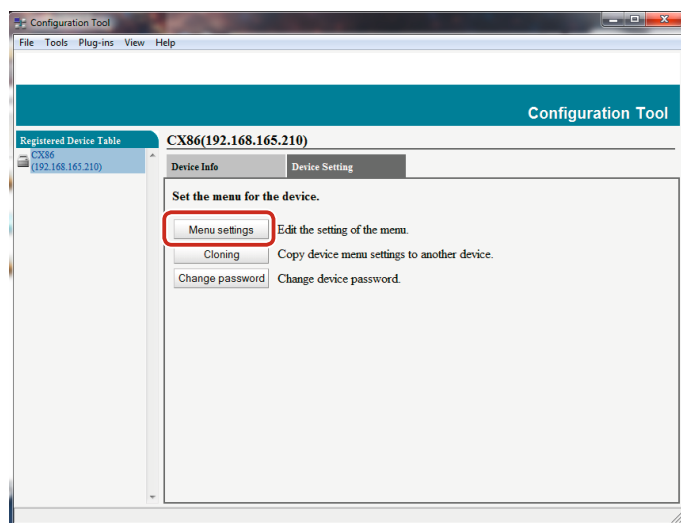

Click [Restore Settings].

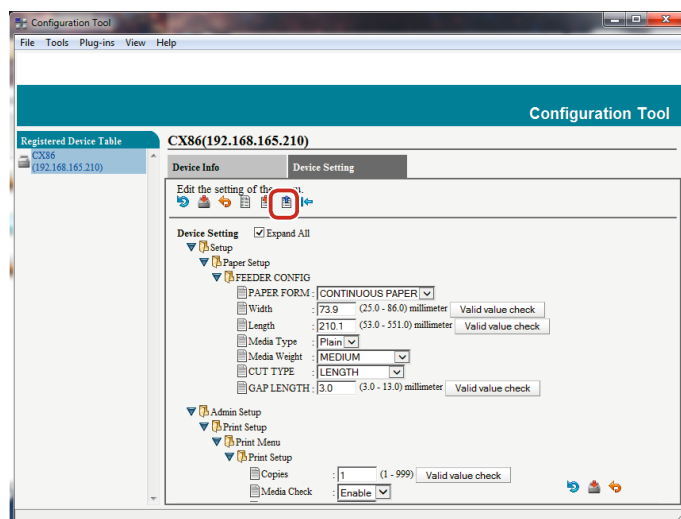

Check the displayed message, and click [Yes].

Select the file to restore, and click [Open].

 Click [Save to device].

Changing the Administrator Password of the Machine

Click [Start], and select [General] > [Configuration Tool].

Select this machine from [Registered Device Table].

Select the [Device Setting] tab.

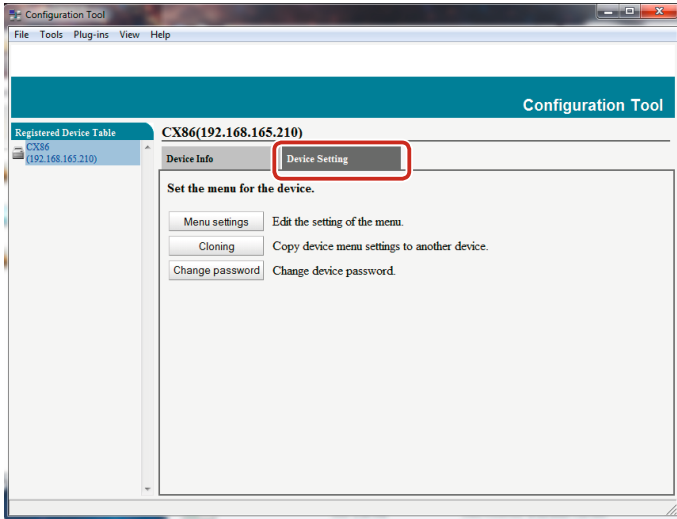

Click [Change password].

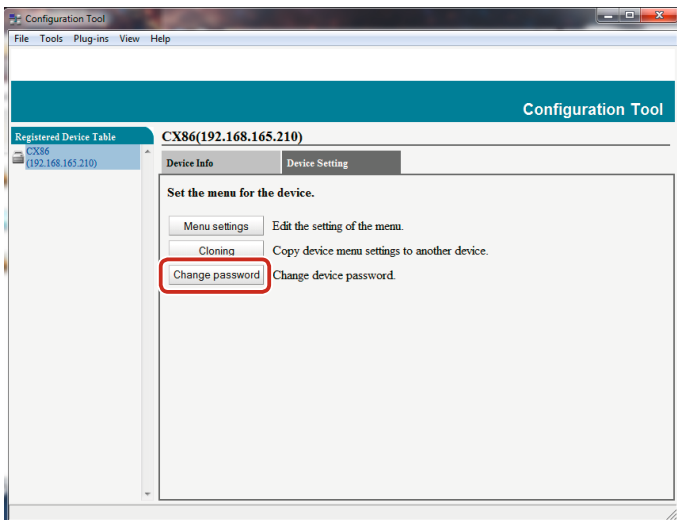

Enter the current password and new password, and click [OK].

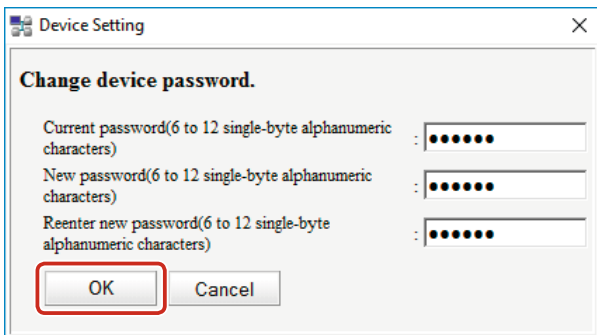

Copying Settings (Cloning)

Menu settings can be copied to another machine.

Click [Start], and select [General] > [Configuration Tool].

Select the machine to clone from [Registered Device Table].

Select the [Device Setting] tab:

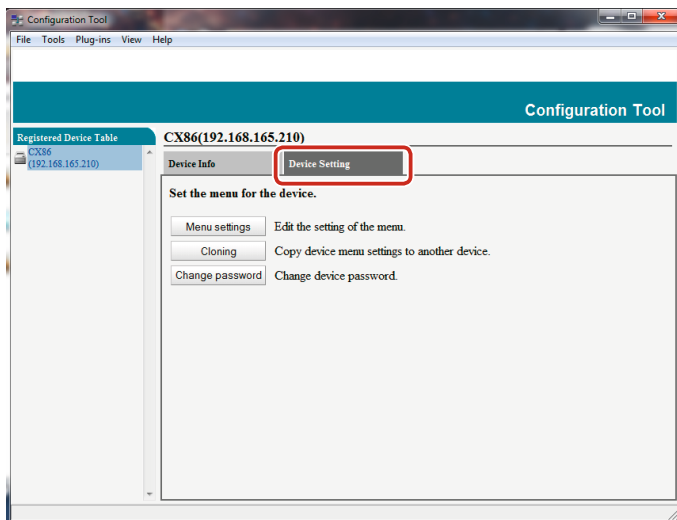

Click [Cloning]:

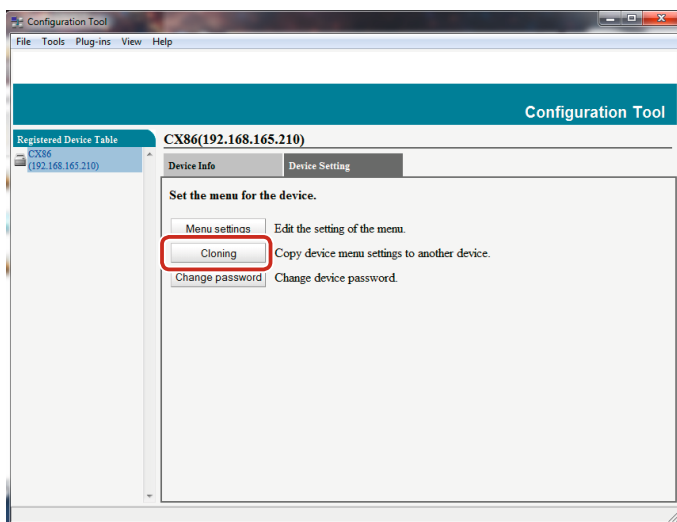

Enter the administrator password, and then click [OK].



- The default password is "999999."

Select the destination device and the cloning settings.

Click [Execute].

Enter the administrator password of the destination device, and click [OK].

The result is displayed.

Configuring the Network

You can configure the network of the machine.

- Searching for the Machine on a Network

Click [Start], and select [General] > [Configuration Tool].

Select [Network Setting] in the [Plug-in] menu.

Select [Discover Devices].

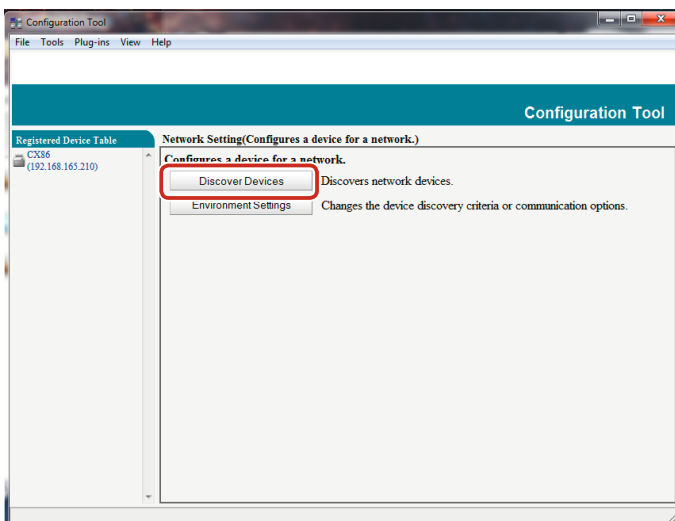

The search results are displayed.

- Specifying the Search Conditions

Click [Start], and select [General] > [Configuration Tool].

Select [Network Setting] in the [Plug-in] menu.

Select [Environment Settings].

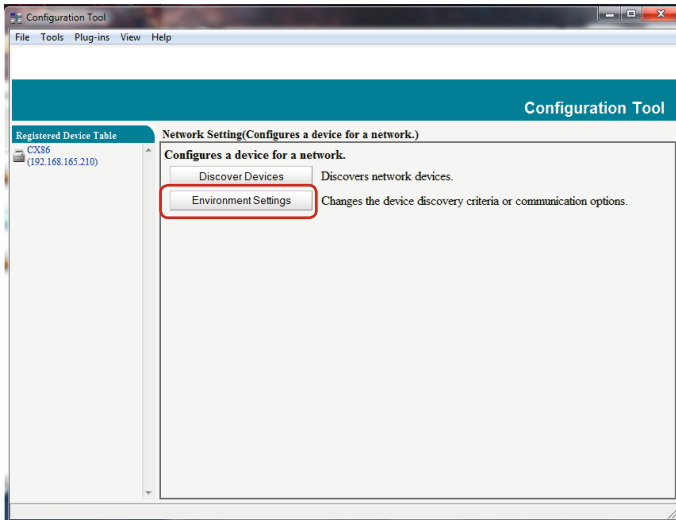

Configure the search conditions as required, and click [OK].

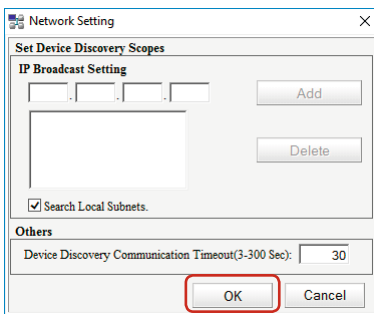

- Changing the IP Address

Click [Start], and select [General] > [Configuration Tool].

Select [Network Setting] in the [Plug-in] menu.

Select [Discover Devices].

Select the machine from the list of devices.

 Click [Device Settings].

Change the settings as required.

Click [Setup].

Enter the administrator password, and then click [OK].



- The default password is "999999."
Click [OK] and restart the device.

Registering Forms (Form Overlay)

Forms for logos, etc. can be registered in the machine for performing overlay printing. This section describes how to register forms.



- For information on performing overlay printing, refer to "Overlaying Text or Logos when Printing".

- **Creating Forms**

Click [Start], and then select [Devices and Printers].

Right-click the icon of the machine, and select the required printer driver in [Printer properties].

Select the [Ports] tab, select [FILE:] in [Port], and select [Apply].

Create the forms to register to the machine.

Print.

Enter the file name to save.

Example: C:\temp\form.prn

Select the original port in [Port] on the [Ports] tab, and select [OK].

- **Registering Forms to the Machine Using the Configuration Tool**

Click [Start], and select [General] > [Configuration Tool].

Select [Storage Manager] in the [Plug-in] menu.



Click [New Project].



Click [Add File to Project], and select the form file you created.

The form is added to the project.

Click the form file.

Enter the form ID (of your choice) in [ID], and click [OK].



- Do not change [Target Volume] or [Path].



- Specify the form ID entered in [ID] when performing overlay printing.

Select the machine in the window on the bottom of the Storage Manager plug-in screen. You can select multiple machines to register forms to.



- If the machine is not registered in the Configuration Tool, refer to “Registering the Machine”.

 Click [Send project files to printer].

Delete items registered in the machine before performing registration.
Select the form, and click [OK].

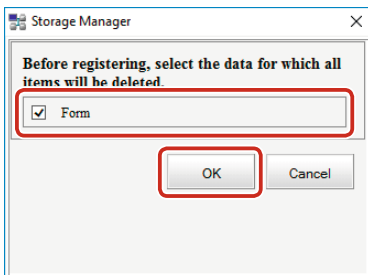

Enter the administrator password, and then click [OK].

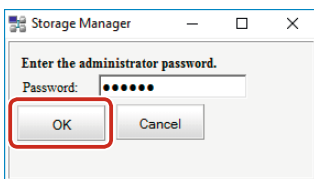

Confirm the setting results, and click [Back].

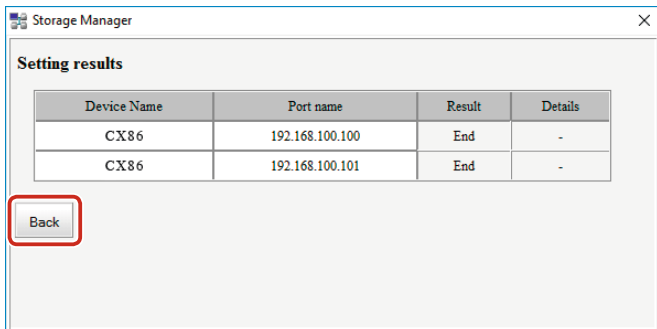

Checking the Free Memory/Storage Space

Click [Start], and select [General] > [Configuration Tool].

Select [Storage Manager] in the [Plug-in] menu.

Click the device name in the device selection area on the bottom of the Storage Manager plug-in screen.

Communicating with the device displays the storage, volume name, size, free space, location name, label, status, file name, size, and comment, etc.

Removing the Machine

You can cancel the registration of the machine.

Click [Start], and select [General] > [Configuration Tool].

Right-click the machine in [Registered Device Table].

Select [Remove device].

Click [Yes] on the confirmation screen.

Names and Functions of Each Screen

This section describes the names and functions of each screen.

- [Device Info] Tab

Displays information related to the machine.

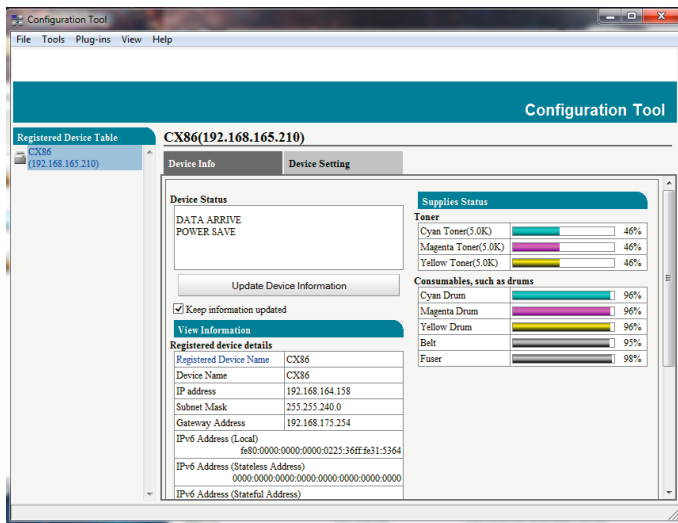

- [Device Setting] Tab

Configures and copies the menus of the machine.

	Item	Description
1	Menu settings	Changes the settings of the menu items of the machine.
2	Cloning	Copies the settings of the menu items of the machine to another machine.
3	Change password	Changes the administrator password of the machine.

- [Network Setting] Plug-in
Configures the network.

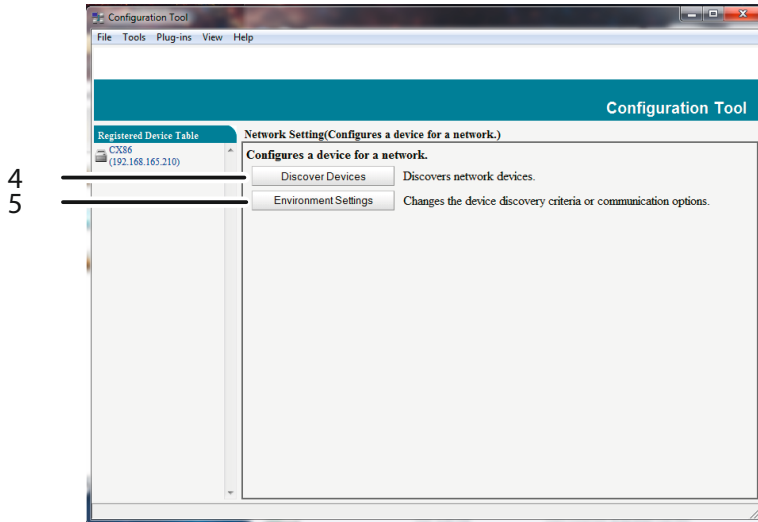

	Item	Description
4	Discover Devices	Discovers network devices.
5	Environment Settings	Changes the device detection standard and communication options.

- [Storage Manager] Plug-in
Registers and edits the files to download to the machine.

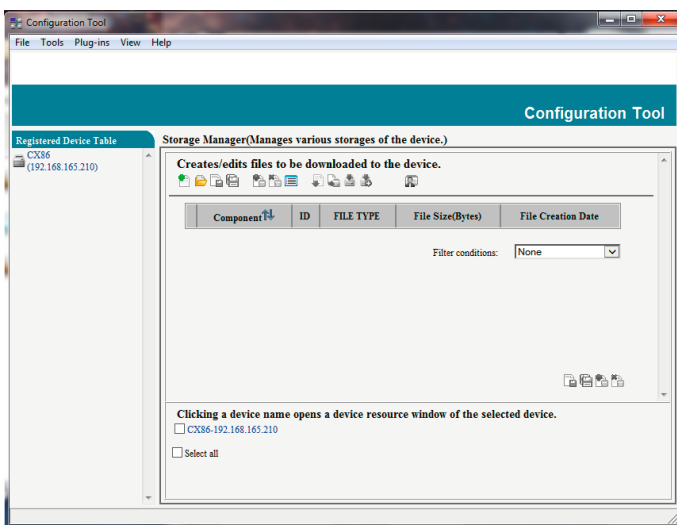

Status Monitor

The Status Monitor is a utility for displaying the status of printers on a computer.

The Status Monitor includes the following functions.

- Displaying the machine status
- Retrieving information included in the following reports as a CSV file

Setting

Error Log

System Requirements

Windows 10/Windows 8.1/Windows 8/Windows 7/Windows Server 2016/Windows Server 2012 R2/Windows Server 2012/Windows Server 2008 R2/Windows Server 2008



- Administrator privileges for the computer are required for setup.
- In order to use the Status Monitor, the printer driver is must be installed in advance, USB or the standard TCP/IP port must be specified for [Ports] in the printer driver, and the machine must be connected.

Starting the Status Monitor

The Status Monitor automatically starts when printing is performed. Perform the procedure below to start it manually.

Select [Start] > [General] > [CX86e Status Monitor] to start the Status Monitor.

Displaying the Printer Status

[Printer State] Tab

No.	Description
1	Displays the name of the printer for monitoring.
2	Displays the printer status as text.
3	Displays the printer status that has occurred concurrently with that on top as text. (Only displayed when connected via USB)
4	Displays all the concurrent statuses of the printer as text.

Switching the Printer Settings

[Printer Setup] Tab

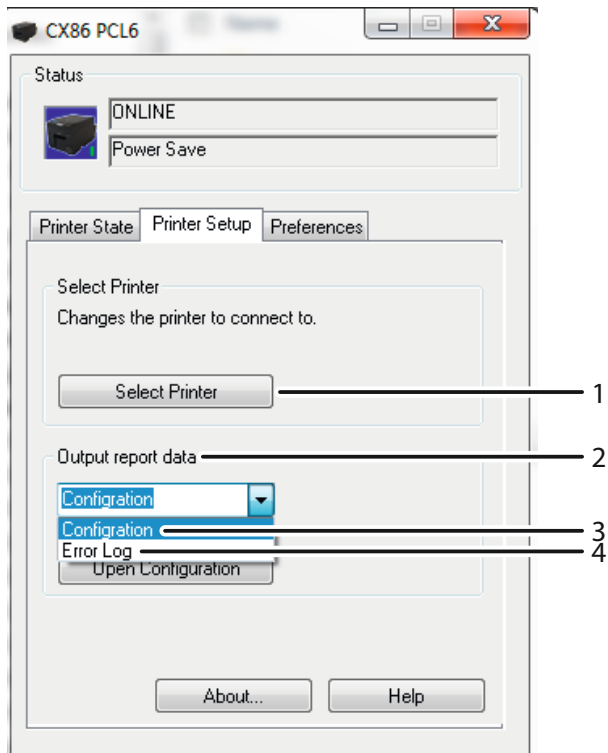

No.		Description
1	Select Printer	Changes the destination printer.
2	Output Report Data	Select [Setting] or [Error Log] from the pull-down menu, and click the [Execute] button to output the report data in the CSV format.
3	Configuration	Outputs detailed information on the printer settings.
4	Error Log	Outputs the error log of the printer.

Switching the Status Monitor Settings

[Preferences] Tab

No.		Description
1	Minimized View	
2	Display Status Panel	Displays the printer status using text and the background color of the icon.
3	Display icon only	Displays the printer status using an icon displayed on the task bar.

No.		Description
4	Alert View	<p>Specifies the display position of the status monitor when a warning occurs in the printer.</p> <p>When selected, a popup is displayed in front when an error occurs in the printer. When deselected, a popup is not displayed, even when an error occurs in the printer.</p>
5	Consumable Warnings	<p>Configures how the consumable warning is displayed.</p> <p>When selected, a warning is displayed for the first warning, etc. of the day when the PC starts. When deselected, a warning is displayed at the start of continuous documents.</p>

Specifications

General Specifications

Model	Model Number
CX86e	CX86/CX86e

Item	CX86e	
CPU	ARM Cortex A9(533MHz)	
Memory	DDR3 16bit 512MB	
ROM	64MB	
Weight (including consumables)	Approx. 9.5kg	
Dimensions (W x D x H)	198mm(7.8") x 380mm(15") x 195mm(7.7")	
Power supply	CX86 : 110 - 127V AC +/-10% CX86e : 220 - 240V AC +/-10%	
Power consumption	Typical operation	Average Approximately 250W
	Idle	Average Approximately 10W
	Peak	650W
	Power save mode	Average Approximately 5W
	Sleep mode	Average Approximately 1W *1
	Auto power off mode	≤ 0.5W
Operating condition	Operating	Temperature:10 - 32 °C Humidity:20 - 80 %RH
	Idle	Temperature:0 - 43 °C Humidity:10 - 90 %RH
Interface	USB 2.0, Ethernet 10BASE-T/100BASE-TX/IEEE802.11 b/g/n/a Wireless LAN (Option),	
Display	16 characters x 2 lines	
Supported OS	Windows 10/Windows Server 2016/ Windows 8.1/Windows Server 2012 R2/ Windows 8/Windows Server 2012/ Windows 7/Windows Server 2008 R2/ Windows Server 2008	
Device service life	120km or 5 years	
Storage environment	Temperature:-10 - 43 °C Humidity:10 - 90 %RH	

*1: Default setting. May differ according to the device settings.

Printing Specifications

Item	CX86e
Printing method	LED color
Page-description language	PCL5c, PCL6(PCLXL)

Item	CX86e
Resident fonts	Bitmap: 4 fonts Scalabel: 27 fonts
Resolution	1200x1200dpi
Color	Yellow, Magenta, Cyan
Print speed	Max 6 IPS
Paper size	Width: 25 - 86 mm Length: 53 - 551 mm
Media type	Plain, User Type 1 - 5
Warm-up time	23 sec
Usage Environment Conditions	When in operation 10 - 32°C/ Relative Humidity of 20 - 80% (maximum wet bulb temperature of 25°C, aximum dry bulb temperature of 2°C) When not in operation 0 - 43°C/ Relative Humidity of 10 - 90% (maximum wet bulb temperature of 26.8°C, maximum dry bulb temperature of 2°C)
Conditions for the guarantee of print quality	Operating Range Temperature 10°C, humidity 20 to 80% RH Temperature 32°C, humidity 20 to 60% RH Humidity 20% RH, temperature 10 to 32°C Humidity 80% RH, temperature 10 to 27°C Full-color Print Quality Assured Range Temperature 17 to 27°C, humidity 50 to 70% RH
Consumables	Toner Cartridge, Image Drum Unit, Transfer Belt Unit, Fuser Unit

Network Related

Item	CX86e
Interfaces	Ethernet 10BASE-T/100BASE-TX, IEEE802.11 a/b/g/n wireless LAN
Protocols	TCP/IPv4, TCP/IPv6, NetBIOS over TCP, LPR, Port9100, IPP, FTP, HTTP, TELNET, SMTP, POP3, SNMPv1/ v3, DHCP, DHCPv6, DNS, DDNS, UPnP, WINS, Bonjour, SNTP, LLTD, Web Services Discovery (WSD), SSL/TLS, IPSec, IEEE802.1X

Wireless LAN Specifications

Item	CX86e
Wireless LAN Standard	IEEE802.11a/b/g/n (2.4 GHz/5 GHz)
Security	Disabled, WEP, WPA-PSK, WPA2-PSK, WPA-EAP, WPA2-EAP

Consumables/Maintenance Parts/Options

Purchase these consumables, maintenance parts, and options from the dealer where you bought the machine.

Consumables

Product Name	Model	Description
Toner Cartridge		Enables printing of approximately 5,000 pages.
Image Drum Unit		Enables printing of approximately 25,000 pages.

Maintenance Parts

Product Name	Model	Description
Fuser Unit		Enables printing of approximately 100,000 pages.
Transfer Belt Unit		Enables printing of approximately 100,000 pages.
Paper Feed Roller		Enables printing of approximately 60 km.
Feed Roller		Enables printing of approximately 60 km.

Options

Product Name	Model	Description
Wireless LAN Module		Enables wireless connections.
Presenter Unit		The Presenter Unit is installed to stop the printed paper before it is fully ejected.

- The print quality deteriorates after one year or more passes since you open the toner cartridge and image drum unit. In this case, prepare a new consumable for replacement.
- Do not open the package until the consumable is ready for use.
- Avoid direct sunlight and store it in a location in the range of 0 to 35°C temperature and 20 to 85% relative humidity.
- Do not store it in a location subject to high or rapid changes in temperatures or humidity.
- Keep it away from children.



DTM Print GmbH
Mainzer Strasse 131
65187 Wiesbaden
Germany
+49 611 92777-0
support@dtm-print.eu
dtm-print.eu

